

# General Specifications

Model ZR22S and ZR202S  
Explosion-proof Direct In Situ  
Zirconia Oxygen Analyzers



GS 11M13A01-01E

## Overview

Two types are available explosion-proof direct in situ zirconia oxygen analyzer. Model ZR22S/ZR402G is a separate type which consists of the ZR22S explosion-proof detector and the ZR402G non-explosion-proof converter. Model ZR202S is an integrated type which combines a probe and a converter.

Separate and integrated type Zirconia oxygen analyzers do not need a sampling device, and allow direct installation of the probe in the wall of a flue or furnace to measure the concentration of oxygen in the stack gas.

The converter displays the cell temperature and cell emf in addition to the oxygen concentration.

This analyzer is most suitable for monitoring combustion and controlling the low-oxygen combustion of various industrial furnaces in explosive atmosphere at petroleum refinery, petrochemical plant, and natural gas plant.



**ZR22S**  
Separate Type  
Explosion-proof Detector

**ZR402G**  
General Use Type  
Converter

**ZR202S**  
Integrated Type  
Explosion-proof Zirconia Oxygen Analyzer

## Features:

- The built-in heater assembly of the probe can be replaced on site, reducing maintenance costs.
- The probe uses a long-life, high-reliability Zirconia sensor.
- The separate type converter ZR402G incorporates a LCD touch-screen for ease of operation.
- The integrated type ZR202S integrates both probe and converter, to reduce wiring, piping, and installation costs. The ZR202S uses an optical switch for ease of operation at the site.
- Remote maintenance using digital communications (HART) reduces maintenance costs. \*1

\*1: HART is a registered trademark of HART Communication Foundation.

## Application Example:

Separate and integrated type Zirconia Oxygen Analyzers

- Large, medium and small boilers (boilers for power generation: heavy oil, gas or coal)
  - Various industrial furnaces (refinery process/iron manufacture heating furnace, coal kiln, and black liquid recovery boilers)
- For other applications, refer to TI 11M12A01-01E.
- May not be applicable corrosive gas such as ammonia and chlorine.

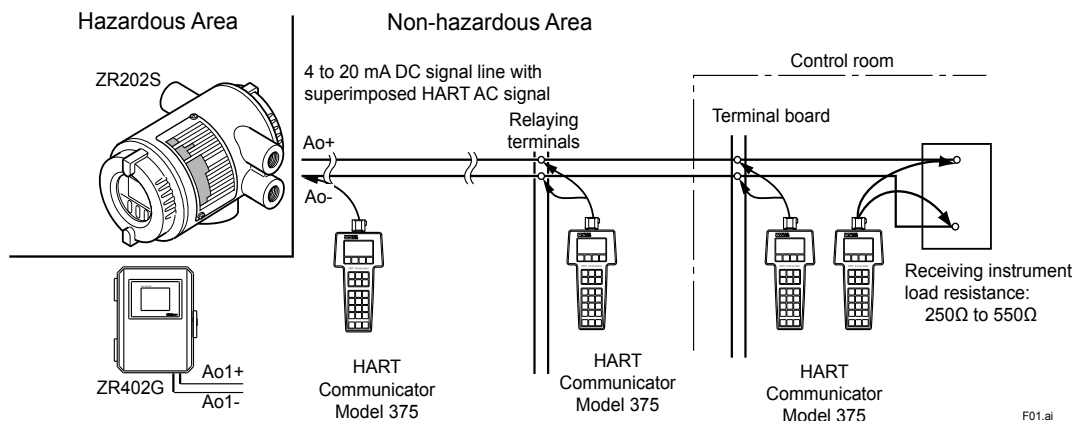

F01.ai

## Basic System Configuration

### System configuration - Separate type Explosion-proof (Automatic Calibration)

#### Example 1

- Automatic calibration system uses instrument air for reference gas.  
For the calibration gas, a standard gas cylinder may be used for more accurate calibration.
- Applications: Oxygen concentration monitoring and control in boilers.  
(for private and public power generation ) and in heating furnaces.

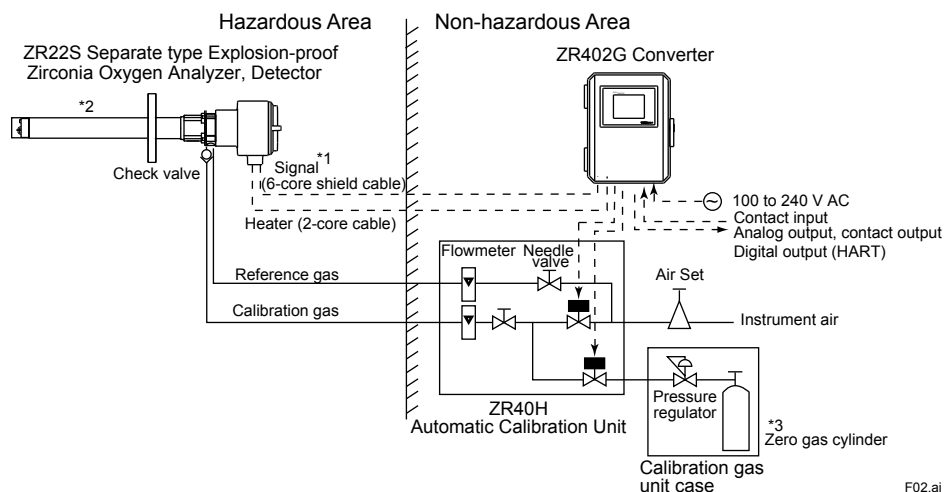

F02.ai

### System configuration - Integrated type Explosion-proof (Automatic Calibration)

#### Example 1

- Automatic calibration system uses instrument air for reference gas.  
For the calibration gas, a standard gas cylinder may be used for more accurate calibration.
- Applications: Oxygen concentration monitoring and control in boilers.  
(for private and public power generation)

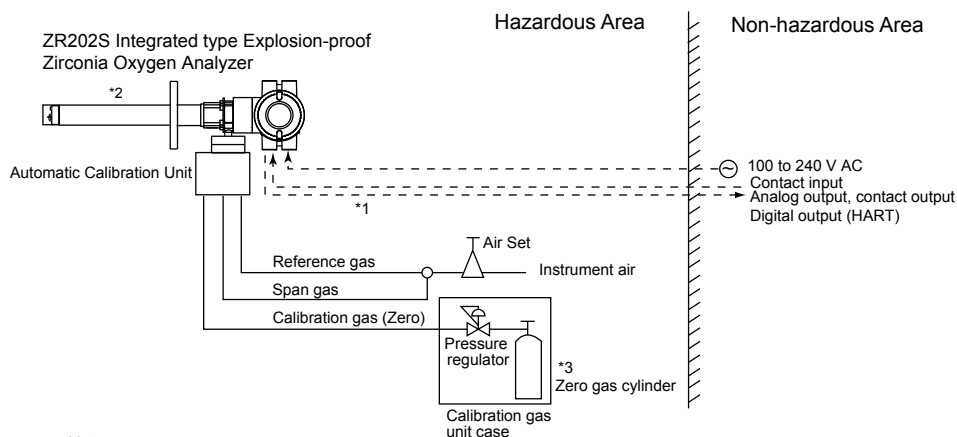

Note:  
The installation temperature limits range for integrated type analyzer is -20 to 55 °C.

F03.ai

- \*1 Shield cable:  
Use shielded signal cables, and connect the shields to the FG terminal of the converter.
- \*2 Select the desired probe from the Detector Components table on page 4.
- \*3 When a zirconia oxygen analyzer is used, 100% N<sub>2</sub> gas cannot be used as the zero gas. Use approx. 1 vol% O<sub>2</sub> gas (N<sub>2</sub>-balanced).

## Basic System Configuration

### System configuration - Separate type Explosion-proof (Manual Calibration)

#### Example 2

- Instrument air is used as the reference gas.  
A standard gas cylinder can be used for the calibration gas for more accurate calibration.
- Application example: Oxygen concentration monitoring and control in boilers.  
(for private and public power generation) and in heating furnaces.

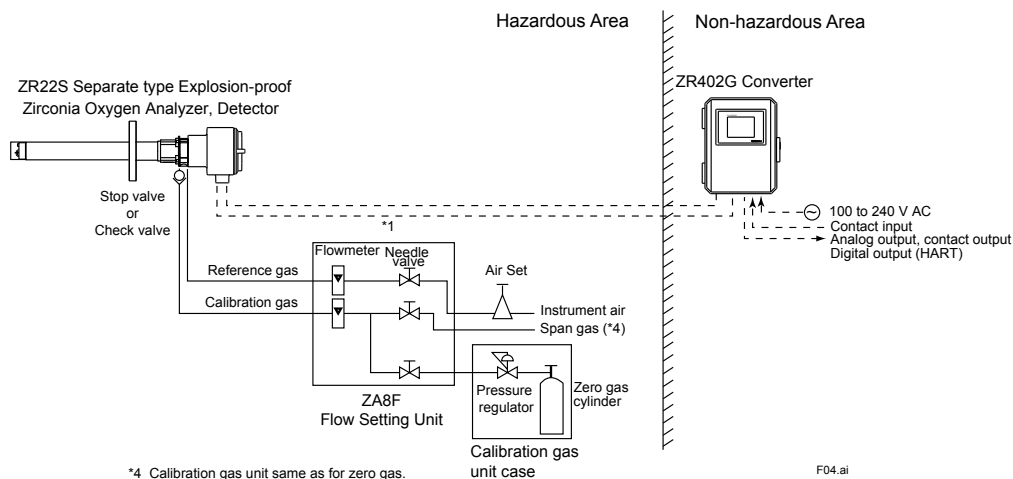

### System configuration - Integrated type Explosion-proof (Manual Calibration)

#### Example 2

- Instrument air is used as the reference gas.  
A standard gas cylinder can be used for the calibration gas for more accurate calibration.
- Application example: Oxygen concentration monitoring and control in boilers.  
(for private and public power generation)

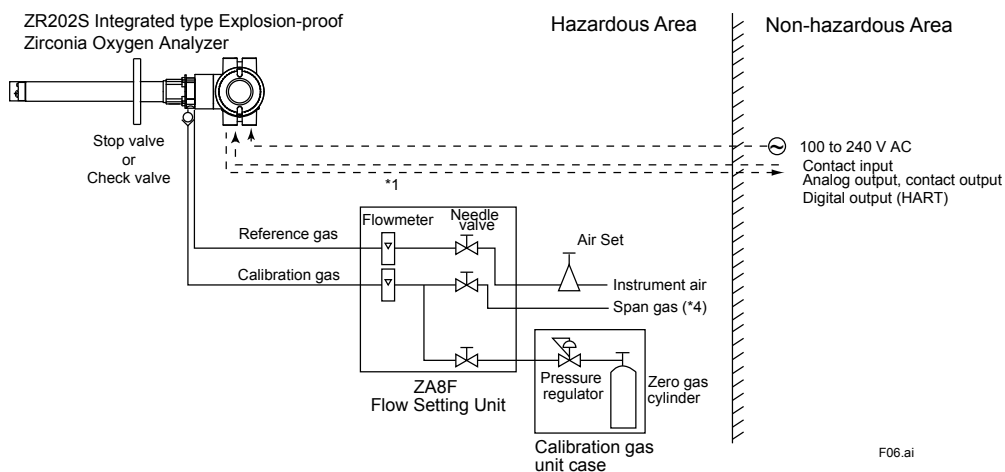

\*1 Shield cable:  
Use shielded signal cables, and connect the shields to the FG terminal of the converter.

## System Components

System Components		Separate type		Integrated type	
		System config.		System config.	
		Ex.1	Ex.2	Ex.1	Ex.2
1	ZR22S Separate type Explosion-proof Zirconia Oxygen Analyzers, Detector	●	●		
2	ZR402G Separate type General use Zirconia Oxygen Analyzer, Converter	●	●		
3	ZR202S Integrated type Explosion-proof Zirconia Oxygen Analyzers			●	●
4	ZO21P High Temperature Probe Adapter for separate type Zirconia Oxygen Analyzer	○	○		
5	E7046EC, E7046EN Ejector Assembly for High Temperature	○	○		
6	ZO21R Probe Protector for Zirconia Oxygen Analyzers	○	○	○	○
7	ZO21S Standard Gas Unit (*2)				
8	ZA8F Flow Setting Unit for manual calibration		●		●
9	ZR40H Automatic Calibration Unit for Separate type Analyzer	●			
10	Automatic Calibration Unit for Integrated type Oxygen Analyzer (*1)			●	
11	L9852CB, G7016XH Stop Valve for Calibration gas line		(●)		(●)
12	K9292DN, K9292DS Check Valve for Calibration gas line	●	(●)		(●)
13	G7003XF/K9473XK, G7004XF/K9473XG Air Set	●	●	●	●
14	G7013XF, G7014XF Pressure Regulator for Gas Cylinder	●	●	●	●
15	ZR22A, ZR202A Heater Assembly for Spare Parts	○	○	○	○

● : Items required for the above system example

○ : To be selected depending on each application. For details, refer to Chapter of Options.

(●) : Select either

(\*1) : When Automatic Calibration of (-A) or (-B) code is specified, Automatic Calibration Unit is installed in ZR202S.

(\*2) : Non CE mark

T01.ai

## Detector Components

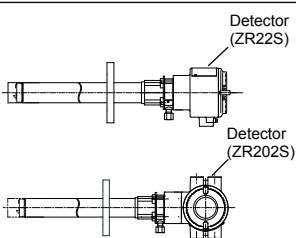
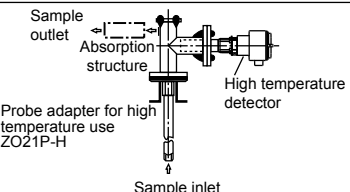
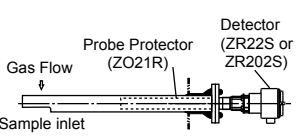
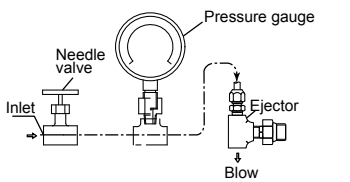
Sample gas temperature 0 to 700°C				Sample gas temperature 700 to 1400°C	
Mounting	Insertion length	General use Probe	Application	High temperature detector	Application
Horizontal to vertical	2 m or less	 <p>Detector (ZR22S)</p> <p>Detector (ZR202S)</p>	Boiler Heating furnace	 <p>Sample outlet</p> <p>Absorption structure</p> <p>High temperature detector</p> <p>Probe adapter for high temperature use ZO21P-H</p> <p>Sample inlet</p> <p>Temperature: Probe material; SUS310S 800°C Probe material; SiC 1400°C Mounting: Vertical downwards Insertion length: 1.0m, 1.5m When duct pressure is atmospheric or negative, attach air ejector.</p>	Heating furnace
		 <p>Gas Flow</p> <p>Probe Protector (ZO21R)</p> <p>Sample inlet</p> <p>Detector (ZR22S or ZR202S)</p>	For pulverized coal boiler with gas flow velocity 10 m/sec or more	 <p>High temperature ejector assembly (E7046EC, E7046EN)</p> <p>Needle valve</p> <p>Pressure gauge</p> <p>Ejector</p> <p>Inlet</p> <p>Blow</p>	

F08.ai

## ■ STANDARD SPECIFICATIONS

### General Specifications

Measurement Object: Oxygen concentration in combustion exhaust gas and mixed gas (excluding inflammable gases, may not be applicable corrosive gas such as ammonia or chlorine is present.)

Measurement System: Zirconia system

Oxygen Concentration: 0.01 to 100 vol%O<sub>2</sub>

Output Signal: 4 to 20 mA DC (maximum load resistance 550 Ω)

Measurement Range: Any setting in the range of 0 to 5 through 0 to 100 vol%O<sub>2</sub> (in 1 vol%O<sub>2</sub>), or partial range

Digital Communication (HART): 250 to 550 Ω, depending on number of field devices connected to the loop (multi-drop mode).

Note: HART is a registered trademark of the HART Communication Foundation.

Display Range: 0 to 100 vol%O<sub>2</sub>

Warm-up Time: Approx. 20 min.

Explosion-proof Approval:

ZR22S-A (ATEX);

Applicable Standard:  
EN 50014:1997+A1,+A2,  
EN 50018:2000+A1,  
EN 50281-1-1:1998+A1

Certificate: KEMA 04ATEX2156

Type of Protection and Marking

Code: EEx d IIB+H<sub>2</sub>

Group: II

Category: 2GD

Temperature Class: T2

The maximum surface temperature for dust-proof: T300°C

Enclosure: IP66

ZR22S-B (FM);

Applicable Standard:  
FM3600 1998, FM3615 1989,  
FM3810 2005,  
ANSI/NEMA 250 1991

Explosion-proof for Class I, Division 1, Groups B, C and D

Dust-ignitionproof for Class II/III, Division 1, Groups E, F and G

Enclosure Rating: NEMA 4X

Temperature Class: T2

ZR22S-C (CSA);

Applicable Standard:  
C22.2 No.0-M1991, C22.2 No. 0.4-04,  
C22.2 No.0.5-1982, C22.2 No.25-1966,  
C22.2 No.30-M1986,  
C22.2 No.94-M91,  
C22.2-No.61010-1-04

Certificate: 1649642

Explosion-proof for Class I, Division 1, Groups B, C and D

Dust-ignitionproof for Class II/III, Division 1, Groups E, F and G

Enclosure: Type 4X

Temperature Class: T2

ZR22S-D (IECEX);

IECEX flameproof type

Applicable Standard:  
IEC 60079-0:2004, IEC 60079-1:2003,  
IEC 61241-0:2004, IEC 61241-1:2004,

Certificate: IECEX KEM 06.0006

Ex d IIB+H<sub>2</sub> T2

Enclosure: IP66

IECEX type of protection "Dust"

Ex tD A21 IP66 T300°C

Enclosure: IP66

ZR202S-A (ATEX);

Applicable Standard:  
EN 50014:1997+A1,+A2,  
EN 50018:2000+A1,  
EN 50281-1-1:1998+A1

Certificate: KEMA 04ATEX2156

Type of Protection and Marking

Code: EEx d IIB+H<sub>2</sub>

Group: II

Category: 2GD

Temperature Class: T2

The maximum surface temperature for dust-proof: T300°C

Enclosure: IP66

ZR202S-B (FM);

Applicable Standard:  
FM3600 1998,  
FM3615 1989, FM3810 2005,  
ANSI/NEMA 250 1991

Explosion-proof for Class I, Division 1, Groups B, C and D

Dust-ignitionproof for Class II/III, Division 1, Groups E, F and G

Enclosure Rating: NEMA 4X

Temperature Class: T2

ZR202S-C (CSA);

Applicable Standard:  
C22.2 No.0-M1991, C22.2 No. 0.4-04,  
C22.2 No.0.5-1982, C22.2  
No.25-1966,  
C22.2 No.30-M1986, C22.2  
No.94-M91,  
C22.2-No.61010-1-04

Certificate: 1649642

Explosion-proof for Class I, Division 1, Groups B, C and D

Dust-ignitionproof for Class II/III, Division 1, Groups E, F and G

Enclosure: Type 4X

Temperature Class: T2

ZR202S-D (IECEX);

IECEX flameproof type

Applicable Standard:  
IEC 60079-0:2004, IEC 60079-1:2003,  
IEC 61241-0:2004, IEC61241-1:2004

Certificate: IECEX KEM 06.0006

Ex d IIB+H<sub>2</sub> T2

Enclosure: IP66

IECEX type of protection "Dust"

Ex tD A21 IP66 T300°C

Enclosure: IP66

(Note)

Explosion-proof approval certificate is valid when ambient temperature including process temperature is between -20°C and 60°C for the ZR22S, and between -20°C and 55°C for the ZR202S.

Safety and EMC conforming standards the ZR22S, ZR402G and ZR202S

Installation altitude based on IEC 61010: 2000 m or less

Category based on IEC 61010: II (Note)

Pollution degree based on IEC 61010: 2 (Note)

Note: Installation category, called over-voltage category, specifies impulse withstand voltage. Category II is for electrical equipment. Pollution degree indicates the degree of existence of solid, liquid, gas or other inclusions which may reduce dielectric strength. Degree 2 is the normal indoor environment.

Safety: EN 61010-1, EN 61010-2-030, CAN/CSA-C22.2 No. 61010.1, UL Std. No. 61010-1  
 EMC: EN 61326-1 Class A, Table 2 (For use in industrial locations), EN 61326-2-3, EN 61000-3-2 EMC Regulatory Arrangement in Australia and New Zealand Korea Electromagnetic Conformity Standard



This instrument is a Class A product, and it is designed for use in the industrial environment. Please use this instrument in the industrial environment only.

#### Repeatability:

± 0.5% Maximum value of set range. (0 to 5 vol%O<sub>2</sub> or more and less than 0 to 25 vol%O<sub>2</sub> range)

± 1% Maximum value of set range. (0 to 25 vol%O<sub>2</sub> or more and up to 0 to 100 vol%O<sub>2</sub> range)

Linearity: (Excluding standard gas tolerance) (Use oxygen of known concentration (with in the measuring range) as the zero and span calibration gases.)

± 1% Maximum value of set range; 0 to 5 vol%O<sub>2</sub> or more and less than 0 to 25 vol%O<sub>2</sub> range

(Sample gas pressure: within ± 4.9 kPa)  
 ± 3% Maximum value of set range; 0 to 25 vol%O<sub>2</sub> or more and less than 0 to 50 vol%O<sub>2</sub> range

(Sample gas pressure: within ± 0.49 kPa)  
 ± 5% Maximum value of set range; 0 to 50 vol%O<sub>2</sub> or more and up to 0 to 100 vol%O<sub>2</sub> range

Drift: (Sample gas pressure: within ± 0.49 kPa) (Excluding the first two weeks in use) Both zero and span ± 2% Maximum value of set range/month

#### Response Time:

Response of 90% within 5 seconds. (Measured after gas is introduced from calibration gas inlet and analog output starts changing.)

### 1. ZR22S Separate type Explosion-proof Zirconia Oxygen Analyzer, Detector

Sample Gas Temperature: 0 to 700°C (Probe only)  
 It is necessary to mount the cell using Inconel cell-bolts when the temperature is greater than 600°C.  
 700 to 1400°C (with High Temperature Probe Adapter)

For high-temperature sample gas, apply 0.15m length probe and High Temperature Probe Adapter ZO21P-H.

A flame arrester may corrode if sample gas contains the following corrosive gases under 380°C or over.

Greater than 5000 ppm SO<sub>2</sub>

Greater than 1000 ppm NO<sub>2</sub>

Greater than 50 ppm HCl

Sample Gas Pressure: -5 to +5 kPa

For 0.15m probe, -0.5 to +5 kPa.

No pressure fluctuation in the furnace should be allowed.

Probe Length: 0.15, 0.4, 0.7, 1.0, 1.5, 2.0 m

Probe Material: SUS316 (JIS)

Ambient Temperature: -20 to +60°C (-20 to +150°C on the terminal box surface)

Reference Gas System: Instrument Air

Instrument Air System: Pressure; 50 kPa plus the pressure inside the furnace (It is recommended to use air which has been dehumidified by cooling to dew point -20°C or less, and dust or oil mist removed.)

Consumption; Approx. 1NI/min

Wetted Material: SUS316 (JIS), Zirconia, SUS304 (JIS) (flange), Hastelloy B, (Inconel 600, 601)

Construction: Heater and thermocouple replaceable construction.

Equivalent to NEMA 4X/IP66. (Achieved when pipes are installed at calibration gas and reference gas inlets and pipe is installed so that reference gas can be exhausted to clean atmosphere. Excluding probe top. And achieved when the cable entry is completely sealed with a cable gland.)

Terminal Box Case: Material; Aluminum alloy

Terminal Box Paint Color:

Case: Mint green (Munsell 5.6BG3.3/2.9)

Cover: Mint green (Munsell 5.6BG3.3/2.9)

Finish: Polyurethane corrosion-resistance coating

Gas Connection: Rc1/4 or 1/4 NPT (Female)

Wiring Connection:

ATEX; M20 × 1.5 or 1/2 NPT select one type (2 pieces)

FM; 1/2 NPT (2 pieces)

CSA; 1/2 NPT (2 pieces)

IECEX; M20 × 1.5 or 1/2 NPT select one type (2 pieces)

Installation: Flange mounting

Probe Mounting Angle: Installing at angles from horizontal to vertical downward is possible.

Weight:

Insertion length of 0.4 m: approx. 13 kg (ANSI 150 4)

Insertion length of 0.7 m: approx. 14 kg (ANSI 150 4)

Insertion length of 1.0 m: approx. 15 kg (ANSI 150 4)

Insertion length of 1.5 m: approx. 17 kg (ANSI 150 4)

Insertion length of 2.0 m: approx. 19 kg (ANSI 150 4)

Available Converter: ZR402G, AV550G



## 2. ZR402G Separate type General purpose Zirconia Oxygen Analyzer, Converter

Converter must not be located in hazardous area.

Operated using an LCD touchscreen on the converter.

Display: LCD display of size 320 by 240 dot with touchscreen.

Output Signal: 4 to 20 mA DC, two points (maximum load resistance 550  $\Omega$ )

Contact Output Signal: Four points (one is fail-safe, normally open)

Contact Input: Two points

Automatic Calibration Output: Two points (for dedicated automatic calibration unit)

Ambient Temperature: -20 to +55°C

Storage Temperature: -30 to +70°C

Ambient Humidity: 0 to 95%RH (non-condensing)

Power Supply Voltage: Ratings; 100 to 240 V AC  
Acceptable range; 85 to 264 V AC

Power Supply Frequency: Ratings; 50/60 Hz  
Acceptable range; 45 to 66 Hz

Power Consumption: Max. 300 W, approx. 100 W for ordinary use.

Maximum Distance between Probe and Converter:  
Conductor two-way resistance must be 10  $\Omega$  or less (when a 1.25 mm<sup>2</sup> cable or equivalent is used, 300 m or less.)

Construction: Outdoor installation, equivalent to NEMA 4X/IP66 (with conduit holes completely sealed with a cable gland)

Wiring Connection: G1/2, Pg 13.5, M20  $\times$  1.5, 1/2 NPT, eight holes

Installation: Panel, wall or 2-inch pipe mounting

Case: Aluminum alloy

Paint Color: Door: Silver gray (Munsell 3.2PB7.4/1.2)

Case: Silver gray (Munsell 3.2PB7.4/1.2)

Finish: Polyurethane corrosion-resistance coating

Weight: Approx. 6 kg

### Functions

Display Functions:

Value Display; Displays values of the measured oxygen concentration, etc

Graph Display; Displays trends of measured oxygen concentration

Data Display; Displays various useful data for maintenance, such as cell temperature, reference junction temperature, maximum/minimum oxygen concentration, or the like

Status Message; Indicates an alarm or error occurrence with flashing of the corresponding icon. Indicates status such as warming-up, calibrating, or the like by icons.

Alarm, Error Display; Displays alarms such as "Abnormal oxygen concentration" or errors such as "Abnormal cell e.m.f." when any such status occurs.

Calibration Functions:

Automatic Calibration; Requires the Automatic Calibration Unit. It calibrates automatically at specified intervals.

Semi-automatic Calibration; Requires the Automatic Calibration Unit. Input calibration direction on the touchscreen or contact, then it calibrates automatically afterwards.

Manual Calibration; Calibration with opening/closing the valve of calibration gas in operation interactively with an LCD touchscreen.

Blowback Function:

Output through the contact in the set period and time. Auto/Semi-Auto selectable.

Maintenance Functions:

Can operate updated data settings in daily operation and checking. Display data settings, calibration data settings, blowback data settings, current output loop check, input/output contact check.

Setup Functions:

Initial settings suit for the plant conditions when installing the converter. Equipment settings, current output data settings, alarm data settings, contact data settings, other settings.

Self-diagnosis:

This function diagnoses conditions of the converter or the detector and indicates when any abnormal condition occurs.

Password Functions:

Enter your password to operate the analyzer excepting data display. Individual passwords can be set for maintenance and setup.

Display and setting content:

Measuring Related Items: Oxygen concentration (vol%O<sub>2</sub>), Output current value (mA), air ratio, moisture quantity (in hot gases) (vol%H<sub>2</sub>O)

Display Items: Cell temperature (°C), thermocouple reference junction temperature (°C), maximum/minimum/average oxygen concentration (vol%O<sub>2</sub>), cell e.m.f. (mV), cell internal resistance ( $\Omega$ ), cell condition (in four grades), heater on-time rate (%), calibration record (ten times), time (year/month/day, hour/minute)

Calibration Setting Items: Span gas concentration (vol%O<sub>2</sub>), zero gas concentration (vol%O<sub>2</sub>), calibration mode (automatic, semi-automatic, manual), calibration type and method (zero-span calibration, zero calibration only, span calibration only), stabilization time (min. sec), calibration time (min. sec), calibration period (day/hour), starting time (year/month/day, hour/minute)

Equipment Related Items: Measuring gas selection

Output Related Items: Analog output/output mode selection, output conditions when warming-up/maintenance/calibrating (during blowback)/abnormal, 4 mA/20 mA point oxygen concentration (vol%O<sub>2</sub>), time constant.

Alarm Related Items: Oxygen concentration high alarm/high-high alarm limit values (vol%O<sub>2</sub>), Oxygen concentration low alarm/low-low alarm limit values (vol%O<sub>2</sub>), Oxygen concentration alarm hysteresis (vol%O<sub>2</sub>), Oxygen concentration alarm detection, alarm delay (seconds)

Contact Related Items: Selection of contact input 1 and 2, selection of contact output 1 to 4 (abnormal, high-high alarm, high alarm, low alarm, low-low alarm, maintenance, calibrating, range switching, warming-up, calibration gas pressure decrease, temperature high alarm, blowback, flameout gas detection, calibration coefficient alarm, stabilization timeout)

Converter Output: Two points mA analog output (4 to 20 mA DC (maximum load resistance of 550  $\Omega$ )) and one mA digital output point (HART) (minimum load resistance of 250  $\Omega$ ).

Range: Any setting between 0 to 5 through 0 to 100 vol%O<sub>2</sub> in 1 vol%O<sub>2</sub>, or partial range is available (Maximum range value/minimum range value 1.3 or more)

For the log output, the minimum range value is fixed at 0.1 vol%O<sub>2</sub>.

4 to 20 mA DC linear or log can be selected. Input/output isolation.

Output damping: 0 to 255 seconds.  
Hold/non-hold selection, preset value setting possible with hold

Contact Output: Four points, contact capacity 30 V DC 3 A, 250 V AC 3 A (resistive load)  
Three of the output points can be selected to either normally energized or normally de-energized status.  
Delayed functions (0 to 255 seconds) and hysteresis function (0 to 9.9 vol%O<sub>2</sub>) can be added to high/low alarms.  
The following functions are programmable for contact outputs.  
(1) Abnormal, (2) High-high alarm, (3) High alarm, (4) Low-low alarm, (5) Low alarm, (6) Maintenance, (7) Calibration, (8) Range switching answer-back, (9) Warm-up, (10) Calibration gas pressure decrease (answer-back of contact input), (11) Temperature high alarm, (12) Blowback start, (13) Flameout gas detection (answer-back of contact input), (14) Calibration coefficient alarm, (15) Startup power stabilization timeout alarm  
Contact output 4 is set to normally operated, fixed error status.

Contact Input: Two points. The following functions are programmable for contact inputs:  
(1) Calibration gas pressure decrease alarm, (2) Range switching, (3) External calibration start, (4) Process alarm (if this signal is received, the heater power turns off), (5) Blowback start

Contact capacity: Off-state leakage current; 3 mA or less

Self-diagnosis: Abnormal cell, abnormal cell temperature (low/high), abnormal calibration, defective A/D converter, defective digital circuit

Calibration: Method; zero/span calibration  
Calibration mode; automatic, semi-automatic and manual (All are operated interactively with an LCD touchscreen).  
Either zero or span can be skipped.

Zero calibration gas concentration setting range: 0.3 to 100 vol%O<sub>2</sub> (0.01 vol%O<sub>2</sub> in smallest units).

Span calibration gas concentration setting range: 4.5 to 100 vol%O<sub>2</sub> (0.01 vol%O<sub>2</sub> in smallest units).

Use N<sub>2</sub>-balanced mixed gas containing 10 vol%O<sub>2</sub> scale of oxygen, and 80 to 100 vol%O<sub>2</sub> scale of oxygen for standard zero-gas and standard span-gas respectively.

Calibration period; date/time setting; maximum 255 days

### 3. ZR202S Integrated type Explosion-proof Zirconia Oxygen Analyzer

Display: 6-digit LCD

Switch: Three optical switches

Output Signal: 4 to 20 mA DC, one point (maximum load resistance 550  $\Omega$ )

Digital Communication (HART): 250 to 550  $\Omega$ , depending on quantity of field devices connected to the loop (multi-drop mode).

Contact Output Signal: Two points (one is fail-safe, normally open)

Contact Input Signal: Two points

Sample Gas Temperature: 0 to 700°C

It is necessary to mount the cell using Inconel cell-bolts when the temperature measures more than 600°C.

High-temperature service — greater than 700°C — is not available.

A flame arrester may corrode if sample gas contains the following corrosive gases under 380°C or over.

Greater than 5000 ppm SO<sub>2</sub>

Greater than 1000 ppm NO<sub>x</sub>

Greater than 50 ppm HCl

Sample Gas Pressure: - 5 to + 5 kPa

No pressure fluctuation in the furnace should be allowed.

Probe Length: 0.4, 0.7, 1.0, 1.5, 2.0 m

Probe Material: SUS316 (JIS)

Ambient Temperature: -20 to +55°C (- 5 to +70°C on the case surface)

Storage Temperature: -30 to +70°C

Ambient Humidity: 0 to 95%RH (non-condensing)

Power Supply Voltage: Ratings; 100 to 240 V AC  
Acceptable range; 85 to 264 V AC

Power Supply Frequency: Ratings; 50/60 Hz  
Acceptable range; 45 to 66 Hz

Power Consumption: Max. 300 W, approx. 100 W for ordinary use.

Reference Gas System: Instrument Air

Instrument Air System: Pressure; 50 kPa + the pressure inside the furnace 150 kPa + the pressure inside the furnace with automatic calibration unit. (It is recommended to use air which has been dehumidified by cooling to dew point -20°C or less, and filtering to remove dust or oil mist.)  
Consumption; Approx. 1.5Nl/min

Wetted Material: SUS316 (JIS), Zirconia, SUS304 (JIS) (flange), Hastelloy B, (Inconel 600, 601)

Construction: Heater and thermocouple replaceable construction.

Equivalent to NEMA 4X/IP66.

(Achieved when pipes are installed at calibration gas and reference gas inlet and exhaust pipe is installed so that reference gas can be exhausted to clean atmosphere. Excluding probe top.)



(Achieved when the cable entry is completely sealed with a cable gland.)

Gas Connection: Rc1/4 or 1/4 NPT (Female)

Wiring Connection:

ATEX; M20 × 1.5, 1/2 NPT  
select one type (4 pieces)  
FM; 1/2 NPT (4 pieces)  
CSA; 1/2 NPT (4 pieces)  
IECEX; M20 × 1.5 or 1/2 NPT  
select one type (4 pieces)

Installation: Flange mounting

Probe Mounting Angle: Horizontal to vertically downward. Installing at angles from horizontal to vertical downward is available.

Case: Aluminum alloy

Paint Color: Cover; Mint green (Munsell 5.6BG3.3/2.9)  
Case; Mint green (Munsell 5.6BG3.3/2.9)

Finish: Polyurethane corrosion-resistance coating

Weight:

Insertion length of 0.4 m: approx. 15 kg (ANSI 150 4)

Insertion length of 0.7 m: approx. 16 kg (ANSI 150 4)

Insertion length of 1.0 m: approx. 17 kg (ANSI 150 4)

Insertion length of 1.5 m: approx. 19 kg (ANSI 150 4)

Insertion length of 2.0 m: approx. 21 kg (ANSI 150 4)

## Functions

Display Function: Displays values of the measured oxygen concentration, etc.

Alarm, Error Display: Displays alarms such as "AL-06" or errors such as "Err -01" when any such status occurs.

Calibration Functions:

Automatic Calibration; Requires the Auto-calibration Unit. It calibrates automatically at specified intervals.

Semi-automatic Calibration; Requires the Automatic Calibration Unit. Input calibration start signal by optical switch or contact, then it calibrates automatically afterwards.

Manual Calibration; Calibration with opening/closing the valve of calibration gas in operation interactively with the optical switch.

Maintenance Functions:

Can operate updated data settings in daily operation and checking. Display data settings, calibration data settings, test settings (current output loop check, input/output contact check).

Setup Functions:

Initial settings suit for the plant conditions when installing the converter. Current output data settings, alarm data settings, contact data settings, other settings.

Display and setting content:

Display Related Items: Oxygen concentration (vol%O<sub>2</sub>), Output current value (mA), air ratio, moisture quantity (in hot gases) (vol%H<sub>2</sub>O), Cell temperature (°C), thermocouple reference junction temperature (°C), maximum/minimum/average oxygen concentration (vol%O<sub>2</sub>), cell e.m.f. (mV), cell internal resistance (Ω), cell condition (in four grades), heater on-time rate (%), calibration record (ten times), time (year/month/day, hour/minute)

Calibration Setting Items: Span gas concentration (vol%O<sub>2</sub>), zero gas concentration (vol%O<sub>2</sub>), calibration mode (automatic, semi-automatic, manual), calibration type and method (zero-span calibration, zero calibration only, span calibration only), stabilization time (min. sec), calibration time (min. sec), calibration period (day/hour), starting time (year/month/day/hour/minute)

Output Related Items: Analog output/output mode selection, output conditions when warming-up/maintenance/calibrating/abnormal, 4 mA/20 mA point oxygen concentration (vol%O<sub>2</sub>), time constant.

Alarm Related Items: Oxygen concentration high alarm/high-high alarm limit values (vol%O<sub>2</sub>), Oxygen concentration low alarm/low-low alarm limit values (vol%O<sub>2</sub>), Oxygen concentration alarm hysteresis (vol%O<sub>2</sub>), Oxygen concentration alarm detection, alarm delay (seconds)

Contact Related Items: Selection of contact input 1 and 2, selection of contact output 1 and 2 (abnormal, high-high alarm, high alarm, low alarm, low-low alarm, maintenance, calibrating, range switching, warming-up, calibration gas pressure decrease, flameout gas detection (answerback of contact input))

Converter Output: One mA analog output (4 to 20 mA DC (maximum load resistance of 550 Ω)) with mA digital output point (HART) (minimum load resistance of 250 Ω). Range: Any setting between 0 to 5 through 0 to 100 vol%O<sub>2</sub> in 1 vol%O<sub>2</sub>, or partial range is available (Maximum range value/minimum range value 1.3 or more)

For the log output, the minimum range value is fixed at 0.1 vol%O<sub>2</sub>. 4 to 20 mA DC linear or log can be selected. Input/output isolation provided. Output damping: 0 to 255 seconds. Hold/non-hold selection, preset value setting possible with hold.

Contact Output: Two points, contact capacity 30 V DC 3 A, 250 V AC 3 A (resistive load)

One of the output points can be selected to either normally energized or normally de-energized status. Delayed functions (0 to 255 seconds) and hysteresis function (0 to 9.9 vol%O<sub>2</sub>) can be added to high/low alarms.

The following functions are programmable for contact outputs.

(1) Abnormal, (2) High high alarm, (3) High alarm, (4) Low-low alarm, (5) Low alarm, (6) Maintenance, (7) Calibration, (8) Range switching answer-back, (9) Warm-up, (10) Calibration gas pressure decrease (answer-back of contact input), (11) Flameout gas detection (answer-back of contact input).

Contact output 2 is set to normally operated, fixed error status.

Contact Input: Two points, voltage-free contacts  
The following functions are programmable for contact inputs:

(1) Calibration gas pressure decrease alarm, (2) Range switching (switched range is fixed), (3) External calibration start, (4) Process alarm (if this signal is received, the heater power turns off)

Self-diagnosis: Abnormal cell, abnormal cell temperature (low/high), abnormal calibration, A/D converter abnormal, digital circuit abnormal

Calibration: Method; zero/span calibration

Calibration mode; automatic, semi-automatic and manual (All are operated using optical switches). Either zero or span can be skipped.

Zero calibration gas concentration setting range: 0.3 to 100 vol%O<sub>2</sub> (in 0.01 vol%O<sub>2</sub>).

Span calibration gas concentration setting range: 4.5 to 100 vol%O<sub>2</sub> (in 0.01 vol%O<sub>2</sub>).  
Use N<sub>2</sub>-balanced mixed gas containing 10 vol%O<sub>2</sub> scale of oxygen for standard zero gas, and 80 to 100 vol%O<sub>2</sub> scale of oxygen for standard span gas.

Calibration period; date/time setting: maximum 255 days

#### 4. ZO21P High Temperature Probe Adapter

Measuring O<sub>2</sub> in the high temperature gases (exceeds 700°C) requires the ZR22S of 0.15 m length and a high-temperature probe adapter.

Sample gas temperature: 0 to 1400°C (when using SiC probe)  
0 to 800°C (when using SUS310S probe adapter)

Sample gas pressure: -0.5 to + 5 kPa. When using in the range of 0 to 25 vol%O<sub>2</sub> or more, the sample gas pressure should be in the range of -0.5 to +0.5 kPa. (Where the sample gas pressure for the high-temperature probe is negative, an ejector assembly is necessary.)

Insertion length: 0.5, 0.6, 0.7, 0.8, 0.9, 1, 1.5 m

Material in Contact with Gas: SUS316 (JIS), SiC or SUS310S, SUS304 (JIS) (flange)

Probe Material: SiC, JIS SUS310S stainless steel

Installation: Flange mounting (FF type or RF type)

Probe Mounting Angle: Vertically downward within ±5°. Where the probe material is SUS310S SS, horizontal mounting is available.

Construction: Non explosion-proof. Rainproof construction

Weight (example): Insertion length of 1.0 m: approx. 5.3 kg (JIS) / approx. 11.3 kg (ANSI)  
Insertion length of 1.5 m: approx. 5.8 kg (JIS) / approx. 11.8 kg (ANSI)

#### 5. E7046EC/E7046EN Ejector Assembly

For use in cases where pressure of sample gas for high temperature detector is negative.

##### 5.1 Needle Valve

Connection: Rc1/4 or 1/4 NPT (Female)

Material: SUS316 (JIS)

(Note) Pipes and connectors are not provided.

##### 5.2 Pressure Gauge Assembly

Material in Contact with Gas: SUS316 (JIS)

Case Material: Aluminum alloy (Paint color; black)

Scale: 0 to 100 kPaG

Connection: R1/4 or 1/4 NPT, SUS304 (JIS) (with Bushing G3/8 × R1/4 or 1/4 NPT)

#### 5.3 Ejector

Ejector Inlet Air Pressure: 29 to 69 kPaG

Air Consumption: Approx. 30 to 40 l/min

Suction gas flow rate: 3 to 7 l/min

Connection: Rc1/4, SUS304 (JIS)

Tube Connection: (Ø6/Ø4 mm or 1/4 inch copper tube or stainless tube)

#### 6. ZO21R Probe Protector

Used when sample gas flow velocity is approx. 10m/sec or more and dust particles wears the detector in cases such as pulverized coal boiler or fluidized bed furnace (or burner) to protect the detector from wearing by dust particles.

Insertion Length: 1.05 m, 1.55 m, 2.05 m

Flange: JIS 5K 65A FF equivalent. ANSI Class 150 4 FF (without serration) equivalent. However, flange thickness is different.

Material: SUS316 (JIS), SUS304 (JIS) (Flange)

Weight: 1.05 m; Approx. 6/10 kg (JIS/ANSI)  
1.55 m; Approx. 9/13 kg (JIS/ANSI)  
2.05 m; Approx. 12/16 kg (JIS/ANSI)

Installation: Bolts, nuts, and washers are provided for detector, probe adapter and process-side flange.

#### 7. ZO21S Standard Gas Unit (\*)

Standard Gas Unit must not be located in hazardous area.

Function: Portable unit for calibration gas supply consisting of span gas (air) pump, zero gas cylinder with sealed inlet, flow rate checker and flow rate needle valve.

Sealed Zero Gas Cylinders (6 provided): E7050BA

Capacity: 1 l

Filled pressure: Approx. 686 kPaG (at 35°C)

Composition: 0.95 to 1.0 vol%O<sub>2</sub>+N<sub>2</sub>-balance

Power Supply: 100, 110, 115, 200, 220, 240 V  
AC±10%, 50/60 Hz

Power Consumption: Max.5 VA

Case Material: SPCC (Cold rolled steel sheet)

Paint Color: Mainframe; Munsell 2.0 GY3.1/0.5 equivalent

Cover; Munsell 2.8 GY6.4/0.9 equivalent

Piping: Ø 6/Ø 4 mm flexible tube connection

Weight: Approx. 3 kg

(\*) Non CE Mark.

#### 8. ZA8F Flow Setting Unit

Used when instrument air is provided.

This unit consists of flowmeters and flow control valves to control the flow rates of calibration gas and reference gas.

Flowmeter Scale: Calibration gas; 0.1 to 1.0 l/min.  
Reference gas; 0.1 to 1.0 l/min.

Construction: Dust-proof and rainproof construction

Case Material: SPCC (Cold rolled steel sheet)

Painting: Baked epoxy resin, Dark-green (Munsell 2.0 GY 3.1/0.5 or equivalent)

Tube Connections: Rc1/4 or 1/4 NPT (Female)

Reference Gas Pressure: Clean air supply of sample gas pressure plus approx. 50 kPaG (or sample gas pressure plus approx. 150kPaG when a check valve is used.). Pressure at inlet of the Flow Setting Unit. (Max. 300 kPaG).

Air Consumption: Approx. 1.5 l/min

Weight: Approx. 2.3 kg

### 9. ZR40H Automatic Calibration Unit for Separate type Oxygen Analyzer

Automatic Calibration Unit must be located in Non-hazardous area.

Used when automatic calibration is required for the separate type and instrument air is provided. The solenoid valves are provided as standard.

Construction: Dust-proof and rainproof construction; NEMA 4X/IP67 - only for case coating solenoid valve, not flowmeter (excluding flowmeter)

Mounting: 2-inch pipe or wall mounting, no vibration

Materials: Body; Aluminum alloy, Piping; SUS316 (JIS), SUS304 (JIS), Flowmeter; MA (Methacrylate resin). Bracket; SUS304 (JIS)

Finish: Polyurethane corrosion-resistance coating, Mint green (Munsell 5.6BG3.3/2.9)

Piping Connection: Rc1/4 or 1/4 NPT (Female)

Power Supply: 24 V DC (from ZR402G)

Power consumption: Approx. 1.3 W

Reference Gas Pressure: Sample gas pressure plus Approx. 150 kPa.  
Pressure at inlet of automatic calibration unit. (690 kPa max.)

Air Consumption: Approx. 1.5 l/min

Weight: Approx. 3.5 kg

Ambient Temperature: -20 to +55°C, no condensing or freezing

Ambient Humidity: 0 to 95%RH

Storage Temperature: -30 to +65°C

### 10. Automatic Calibration Unit for Integrated type Oxygen Analyzer

When Automatic Calibration of (-A) or (-B) code is specified, Automatic Calibration Unit is installed in the ZR202S.

Only Automatic Calibration Unit is not available.

### 11. L9852CB/G7016XH Stop Valve

The stop valve and the nipple are mounted on the calibration gas line.

The nipple is used to connect the stop valve. They are attached when the option code (/SV) is selected for the ZR22S or the ZR202S.

Connection: Rc1/4 (L9852CB) or 1/4 NPT (F) (G7016XH)

Material: SUS316 (JIS)

Weight: Approx. 150 g

### 12. K9292DN/K9292DS Check Valve

This is used to prevent entry of sample gas into calibration gas line. Purpose is the same as stop valve, but is convenient, as it does not need to be opened or closed for calibration.

Mount directly on calibration gas inlet of detector in place of stop valve. However as source pressure of 150 kPaG or more is needed, standard gas unit cannot be used.

When option code "/CV" of the ZR22S or the ZR202S is specified, check valve is provided.

Connection: Rc1/4 (K9292DN) or 1/4 NPT (F) (K9292DS)

Material: SUS304 (JIS)

Pressure: 70 kPaG or more and 350 kPaG or less

Weight: Approx. 90g

### 13. Air Set

This set is used to lower the pressure when instrument air is used as the reference and span gases.

#### G7003XF/K9473XK

Primary Pressure: Max. 1 MPaG

Secondary Pressure: 0.02 to 0.2 MPaG

Connection: Rc1/4 or 1/4 NPT (F) with joint adapter

Weight: Approx. 1 kg

#### G7004XF/K9473XG

Primary Pressure: Max. 1 MPaG

Secondary Pressure: 0.02 to 0.5 MPaG

Connection: Rc1/4 or 1/4 NPT (F) with joint adapter

Weight: Approx. 1 kg

### 14. G7013XF/G7014XF Pressure Regulator

Primary Pressure: 14.8 MPaG,

Secondary Pressure: 0 to 0.4 MPaG

Connection: Inlet; W22 14 threads, right hand screw  
Outlet; Rc1/4 or 1/4 NPT (Female)

Material: Brass body

### 15. ZR22A, ZR202A Heater Assembly

ZR22A: Spare Parts for ZR22S

ZR202A: Spare Parts for ZR202S

(Note) Yokogawa shall not guarantee the heater assembly after its replacement.

### 16. E7044KF Case Assembly of Calibration Gas Cylinder

Installation: 2B pipe mounting

Material: SPCC (Cold rolled steel sheet)

Case Paint: Baked epoxy resin,  
Jade green (Munsell 7.5 BG 4/1.5)

Weight: Approx. 10 kg with gas cylinder

(Note) Export of such high pressure filled gas cylinders to most countries is prohibited or restricted.

## Model and Suffix Codes

### 1. Separate type Explosion-proof Zirconia Oxygen Analyzer, Detectors

Model	Suffix code	Option code	Description
ZR22S	-----	-----	Separate type Explosion-proof Zirconia Oxygen Analyzer, Detector
Explosion-proof Approval (*12)	-A	-----	ATEX certified flameproof (*11)
	-B	-----	FM certified explosion-proof
	-C	-----	CSA certified explosion-proof
	-D	-----	IECEX certified flameproof (*11)
	-Q	-----	EAC with PA certified explosion-proof (*13)
-R	-----	EAC certified explosion-proof (*13)	
Length	-015	-----	0.15 m (for high temperature use) (*1)
	-040	-----	0.4 m
	-070	-----	0.7 m
	-100	-----	1.0 m
	-150	-----	1.5 m
	-200	-----	2.0 m
Wetted material	-S	-----	Stainless steel
	-C	-----	Stainless steel with Inconel calibration gas tube (*7)
Flange (*2)	-A	-----	ANSI Class 150 2 RF SUS304 (JIS) (*10)
	-B	-----	ANSI Class 150 3 RF SUS304 (JIS)
	-C	-----	ANSI Class 150 4 RF SUS304 (JIS) (*10)
	-E	-----	DIN PN10 DN50 A SUS304 (JIS)
	-F	-----	DIN PN10 DN80 A SUS304 (JIS)
	-G	-----	DIN PN10 DN100 A SUS304 (JIS)
	-K	-----	JIS 5K 65 FF SUS304 (JIS)
	-L	-----	JIS 10K 65 FF SUS304 (JIS)
	-M	-----	JIS 10K 80 FF SUS304 (JIS)
	-P	-----	JIS 10K 100 FF SUS304 (JIS)
	-Q	-----	JIS 5K 32 FF SUS304 (JIS) (for high temperature use) (*3)
	-R	-----	JPI Class 150 4 RF SUS304 (JIS)
	-S	-----	JPI Class 150 3 RF SUS304 (JIS)
-W	-----	Westinghouse	
Reference gas	-E	-----	External connection (Instrument air) (*8)
Gas thread	-R	-----	Rc1/4
	-T	-----	1/4 NPT (Female)
Connection box thread	-M	-----	M20 x1.5 mm
	-T	-----	1/2 NPT (*9)
Instruction manual	-E	-----	English
—	-A	-----	Always -A
Options	Valves	/C	Inconel bolt (*4)
		/CV	Check valve (*5)
		/SV	Stop valve (*5)
	Tag plates	/SCT	Stainless steel tag plate (*6)
		/PT	Printed tag plate (*6)

\*1: Used with the ZO21P High Temperature Probe Adapter. Select flange (-Q).

\*2: The thickness of the flange depends on its dimensions\*3 The thickness of the flange depends on its dimensions.

\*3: The flange thickness does not conform to JIS specification.

\*4: Inconel probe bolts and U shape pipe are used. Use this option for high temperature use (ranging from 600 to 700°C).

\*5: Specify either /CV or /SV option code.

\*6: Specify either /SCT or /PT option code.

\*7: Recommended if sample gas contains corrosive gas like chlorine.

\*8: Piping for reference gas must be installed to supply reference gas constantly at a specified flow rate.

\*9: When selecting code -B (FM certified explosion-proof) or -C (CSA certified explosion-proof), select code -T (1/2 NPT).

\*10: Confirm inside diameter of pipe attached to customer's flange in case that -A or -E is selected.

\*11: The cable entry devices (cable glands etc.) and blind plugs shall be in type of protection Ex "d" or Ex "tb", suitable for the conditions of use and correctly installed. They shall provide a degree of ingress protection of at least IP66.

\*12: When using ZR22S as CE marking compliance product, select -A (ATEX certified flameproof).

\*13: "-Q" is the explosion-proof type of EAC with Pattern Approval for Russia. "-R" is the explosion-proof type of EAC for Kazakhstan and Belarus.

#### Standard Accessory

Item	Parts No.	Q'ty	Description
Allen wrench	L9827AB	1	For lock screw

## 2. Separate type General Use Zirconia Oxygen Analyzer, Converter

Model	Suffix code	Option code	Description
ZR402G	-----	-----	Separate type Zirconia Oxygen Analyzer, Converter
Converter thread	-P -G -M -T	----- ----- ----- -----	G1/2 Pg 13.5 M20 x 1.5 1/2 NPT
Display	-J -E -G -F -C	----- ----- ----- ----- -----	Japanese English German French Chinese
Instruction manual	-J -E -C	----- ----- -----	Japanese English Chinese
—	-A	-----	Always -A
Options		/H	Hood (*2)
Tag plates		/SCT /PT	Stainless steel tag plate (*1) Printed tag plate (*1)
NAMUR NE43 compliant		/C2 /C3	Failure alarm down-scale: Output status at CPU failure and hardware error is 3.6 mA or less (*3) Failure alarm up-scale: Output status at CPU failure and hardware error is 21.0 mA or more (*3)
Standard		/EQ /ER	EAC with PA (*4) EAC (*4)

\*1: Specify either /SCT or /PT option code.

\*2: Sun shield hood is still effective even if scratched.

\*3: Output signal limits: 3.8 to 20.5 mA. Specify either /C2 or /C3 option code.

\*4: "/EQ" is EAC with Pattern Approval for Russia. "/ER" is EAC for Kazakhstan and Belarus.

### Standard Accessories

Item	Parts No.	Q'ty	Description
Fuse	A1113EF	1	3.15 A
Bracket	F9554AL	1	For pipe, panel, or wall mounting
Screws for Bracket	F9123GF	1	



### 3. Integrated type Explosion-proof Zirconia Oxygen Analyzer

Model	Suffix code	Option code	Description
ZR202S	-----	-----	Integrated type Explosion-proof Zirconia Oxygen Analyzer
Explosion-proof Approval (*12)	-A	-----	ATEX certified flameproof (*11)
	-B	-----	FM certified explosion-proof
	-C	-----	CSA certified explosion-proof
	-D	-----	IECEX certified flameproof (*11)
	-Q	-----	EAC with PA certified explosion-proof (*14)
	-R	-----	EAC certified explosion-proof (*14)
Length	-040	-----	0.4 m
	-070	-----	0.7 m
	-100	-----	1.0 m
	-150	-----	1.5 m
	-200	-----	2.0 m
Wetted material	-S	-----	Stainless steel
	-C	-----	Stainless steel with Inconel calibration gas tube (*7)
Flange (*1)	-A	-----	ANSI Class 150 2 RF SUS304 (JIS) (*10)
	-B	-----	ANSI Class 150 3 RF SUS304 (JIS)
	-C	-----	ANSI Class 150 4 RF SUS304 (JIS)
	-E	-----	DIN PN10 DN50 A SUS304 (JIS) (*10)
	-F	-----	DIN PN10 DN80 A SUS304 (JIS)
	-G	-----	DIN PN10 DN100 A SUS304 (JIS)
	-K	-----	JIS 5K 65 FF SUS304 (JIS)
	-L	-----	JIS 10K 65 FF SUS304 (JIS)
	-M	-----	JIS 10K 80 FF SUS304 (JIS)
	-P	-----	JIS 10K 100 FF SUS304 (JIS)
	-R	-----	JPI Class 150 4 RF SUS304 (JIS)
	-S	-----	JPI Class 150 3 RF SUS304 (JIS)
	-W	-----	Westinghouse
Automatic Calibration	-N	-----	Not required
	-A	-----	Horizontal mounting (*5)
	-B	-----	Vertical mounting (*5)
Reference gas	-E	-----	External connection (Instrument air) (*8)
Gas Thread	-R	-----	Rc1/4
	-T	-----	1/4 NPT (F)
Connection box thread	-M	-----	M20 x 1.5
	-T	-----	1/2 NPT (*9)
Instruction manual	-E	-----	English
—	-A	-----	Always -A
Options	Valves	/C	Inconel bolt (*2)
		/CV	Check valve (*3)
		/SV	Stop valve (*3)
	Tag plates	/H	Hood (*6)
		/SCT	Stainless steel tag plate (*4)
	NAMUR NE43 compliant	/PT	Printed tag plate (*4)
		/C2	Failure alarm down-scale: Output status at CPU failure and hardware error is 3.6 mA or less (*13)
	/C3	Failure alarm up-scale: Output status at CPU failure and hardware error is 21.0 mA or more (*13)	

\*1 The thickness of the flange depends on its dimensions.

\*2 Inconel probe bolts and U shape pipe are used. Use this option for high temperature use (ranging from 600 to 700°C).

\*3 Specify either /CV or /SV option code.

\*4 Specify either /SCT or /PT option code.

\*5 No need to specify the option codes, /CV and /SV, since the check valves are provided with the automatic calibration unit.

\*6 Sun shield hood is still effective even if scratched. Hood is necessary for outdoor installation out of sun shield roof.

\*7 Recommended if sample gas contains corrosive gas like chlorine.

\*8 Piping for reference gas must be installed to supply reference gas constantly at a specified flow rate.

\*9 When selecting code -B (FM certified explosion-proof) or -C (CSA certified explosion-proof), select code -T(1/2 NPT).

\*10 Confirm inside diameter of pipe attached to customer's flange in case that -A or -E is selected.

\*11 The cable entry devices (cable glands etc.) and blind plugs shall be in type of protection Ex "d" or Ex "tb", suitable for the conditions of use and correctly installed. They shall provide a degree of ingress protection of at least IP66.

\*12 When using ZR22S as CE marking compliance product, select -A (ATEX certified flameproof).

\*13 Output signal limits: 3.8 to 20.5 mA. Specify either /C2 or /C3 option code.

\*14 "-Q" is the explosion-proof type of EAC with Pattern Approval for Russia. "-R" is the explosion-proof type of EAC for Kazakhstan and Belarus.

#### Standard Accessories

Item	Parts No.	Q'ty	Description	Item	Parts No.	Q'ty	Description
Fuse	A1113EF	1	3.15A	Allen wrench	L9827AB	1	For lock screw

#### 4. High Temperature Probe Adapter for separate type Oxygen Analyzer

Model	Suffix code	Option code	Description
ZO21P	-H	-----	High Temperature Probe Adapter
Material	-A -B	----- -----	SiC SUS310S (JIS)
Insertion length	-050 -060 -070 -080 -090 -100 -150	----- ----- ----- ----- ----- ----- -----	0.5 m 0.6 m 0.7 m 0.8 m 0.9 m 1.0 m 1.5 m
Flange	-J -N -M -L -A -R -Q -T -S -E	----- ----- ----- ----- ----- ----- ----- ----- ----- -----	JIS 5K 50 FF SUS304 (JIS) JIS 10K 65 FF SUS304 (JIS) JIS 10K 80 FF SUS304 (JIS) JIS 10K 100 FF SUS304 (JIS) ANSI Class 150 4 RF SUS304 (JIS) ANSI Class 150 2 1/2 RF SUS304 (JIS) ANSI Class 150 3 RF SUS304 (JIS) JPI Class 150 3 RF SUS304 (JIS) JPI Class 150 4 RF SUS304 (JIS) DIN PN10 DN50 A SUS304 (JIS)
Style code	*B	-----	Style B
Option	Ejector Tag plate	/EJ1 /EJ2 /SCT	Ejector Assy with E7046EC Ejector Assy with E7046EN Stainless steel tag plate

Note: For high temperature probe adapter, be sure to specify the ZR22S probe of its insertion length 0.15 m.

#### High Temperature Probes (Spare Parts)

Part No.	Description
K9292TP	SiC, insertion length 0.5 m
E7046CF	SiC, insertion length 0.6 m
K9292TQ	SiC, insertion length 0.7 m
E7046CG	SiC, insertion length 0.8 m
E7046CH	SiC, insertion length 0.9 m
E7046AL	SiC, insertion length 1.0 m
E7046BB	SiC, insertion length 1.5 m
K9292TV	SUS310S (JIS), insertion length 0.5 m
E7046CR	SUS310S (JIS), insertion length 0.6 m
K9292TW	SUS310S (JIS), insertion length 0.7 m
E7046CS	SUS310S (JIS), insertion length 0.8 m
E7046CT	SUS310S (JIS), insertion length 0.9 m
E7046AP	SUS310S (JIS), insertion length 1.0 m
E7046AQ	SUS310S (JIS), insertion length 1.5 m

#### 5. Ejector Assembly for High Temperature

Part No.	Description
E7046EC	Needle valve; Rc1/4, Pressure gauge; R1/4, Ejector; Ø6 / Ø4 Tube joint
E7046EN	Needle valve; 1/4 NPT (F), Pressure gauge; 1/4 NPT (M), Ejector; 1/4 Tube joint

#### 6. Probe Protector for Zirconia Oxygen Analyzers

Model	Suffix code	Option code	Description
ZO21R	-L	-----	Probe Protector(0 to 700°C)
Insertion length	-100 -150 -200	----- ----- -----	1.05 m 1.55 m 2.05 m
Flange (*)	-J -A	----- -----	JIS 5K 65 FF SUS304 (JIS) ANSI Class 150 4 FF SUS304 (JIS)
Style code	*B	-----	Style B

\*: Thickness of flange depends on dimensions of flange.

#### 7. Standard Gas Unit

Model	Suffix code	Option code	Description
ZO21S	-----	-----	Standard gas unit
Power supply	-2 -3 -4 -5 -7 -8	----- ----- ----- ----- ----- -----	200 V AC 50/60 Hz 220 V AC 50/60 Hz 240 V AC 50/60 Hz 100 V AC 50/60 Hz 110 V AC 50/60 Hz 115 V AC 50/60 Hz
Panel	-J -E	----- -----	Japanese version English version
Style code	*A	-----	Style A

#### 8. Flow Setting Unit for manual calibration

Model	Suffix code	Option code	Description
ZA8F	-----	-----	Flow setting unit
Joint	-J -A	----- -----	Rc1/4 With 1/4 NPT (F) adapter
Style code	*C	-----	Style C

#### 9. Automatic Calibration Unit for Separate type Oxygen Analyzer

Model	Suffix code	Option code	Description
ZR40H	-----	-----	Automatic calibration unit for ZR402G
Gas piping connection	-R -T	----- -----	Rc1/4 1/4 NPT (F)
Wiring connection	-P -G -M -T	----- ----- ----- -----	Pipe connection (G1/2) Pg 13.5 M20 x 1.5 1/2 NPT
—	-A	-----	Always -A

(\*) CE marking (pending).

### 10. Automatic Calibration Unit for Integrated type Oxygen Analyzer ZR202S

When auto calibration of (-A) or (-B) code is specified, Automatic Calibration Unit is installed in the ZR202S. When (-N) is selected, Automatic Calibration Unit is not available.

### 11. Stop Valve for Calibration gas line

Part No.	Description
L9852CB	Joint: Rc/4, Material: SUS316 (JIS)
G7016XH	Joint: 1/4 NPT (F), Material: SUS316 (JIS)

Part No.	Description
G7209XA	Nipple: R1/4, Material; SUS316 (JIS)
K9470ZN	Nipple: 1/4 NPT (F), Material; SUS316 (JIS)

### 12. Check Valve for Calibration gas line

Part No.	Description
K9292DN	Joint: Rc1/4, Material: SUS304 (JIS)
K9292DS	Joint: 1/4 NPT (F), Material: SUS304 (JIS)

### 13. Air Set

Part No.	Description
G7003XF	Joint: Rc1/4, Material: Zinc alloy
K9473XK	Joint: 1/4 NPT(F), Material: Zinc alloy with adapter
G7004XF	Joint: Rc1/4, Material: Zinc alloy
K9473XG	Joint: 1/4 NPT(F), Material: Zinc alloy with adapter

### 14. Pressure Regulator for Gas Cylinder

Part No.	Description
G7013XF	Inlet: W22 14 threads Outlet: Rc1/4
G7014XF	Inlet: W22 14 threads Outlet: 1/4 NPT(Female)

### 15. Heater Assembly

Style: S2

Model	Suffix code	Option code	Description
ZR22A	-----	-----	Heater Assembly for ZR22
Length (*1)	-015	-----	0.15 m
	-040	-----	0.4 m
	-070	-----	0.7 m
	-100	-----	1 m
	-150	-----	1.5 m
	-200	-----	2 m
Jig for change	-A	-----	with Jig (*2)
	-N	-----	None
—	-A	-----	Always -A

\*1 Suffix code of length should be selected as same as ZR22S installed.

\*2 Jig part no. is K9470BX to order as a parts after purchase.

(Note) The heater is made of ceramic, do not drop or subject it to pressure stress. Yokogawa shall not guarantee the heater assembly after its replacement.

Model	Suffix code	Option code	Description
ZR202A	-----	-----	Heater Assembly for ZR202
Length (*1)	-040	-----	0.4 m
	-070	-----	0.7 m
	-100	-----	1 m
	-150	-----	1.5 m
	-200	-----	2 m
	Jig for change	-A	-----
-N		-----	None
—	-A	-----	Always -A

\*1 Suffix code of length should be selected as same as ZR202S installed.

\*2 Jig part no. is K9470BX to order as a parts after purchase.

(Note) The heater is made of ceramic, do not drop or subject it to pressure stress. Yokogawa shall not guarantee the heater assembly after its replacement.

## EXTERNAL DIMENSIONS

### 1. ZR22S Separate type Explosion-proof Zirconia Oxygen Analyzer, Detectors

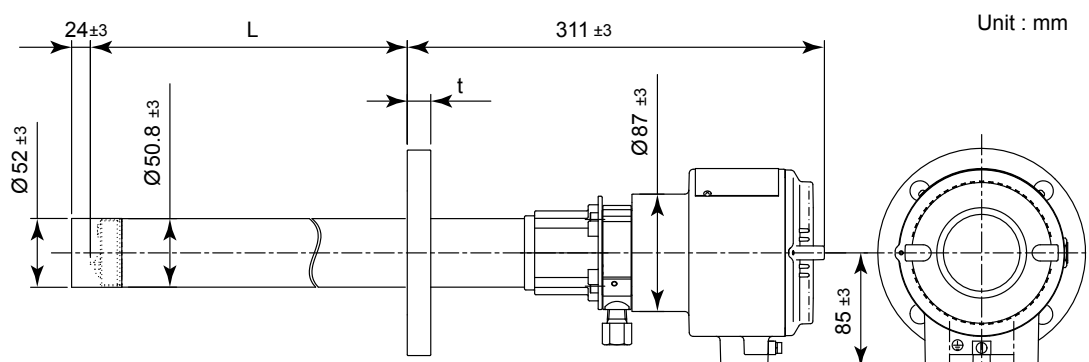

L (m)	tolerance (mm)
0.15	±4
0.4	±5
0.7	±7
1.0	±8
1.5	±10
2.0	±12

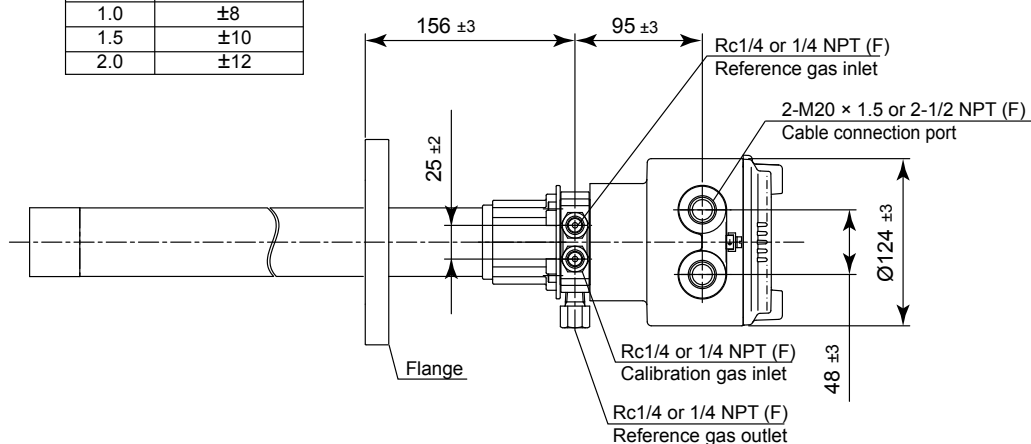

Flange	A	B	n	C	t
ANSI Class 150 2 RF 304 SS (JIS)	152.4	120.6	4	19	19
ANSI Class 150 3 RF 304 SS (JIS)	190.5	152.4	4	19	24
ANSI Class 150 4 RF 304 SS (JIS)	228.6	190.5	8	19	24
DIN PN10 DN50 A 304 SS (JIS)	165	125	4	18	18
DIN PN10 DN80 A 304 SS (JIS)	200	160	8	18	20
DIN PN10 DN100 A 304 SS (JIS)	220	180	8	18	20
JIS 5K 65 FF 304 SS (JIS)	155	130	4	15	14
JIS 10K 65 FF 304 SS (JIS)	175	140	4	19	18
JIS 10K 80 FF 304 SS (JIS)	185	150	8	19	18
JIS 10K 100 FF 304 SS (JIS)	210	175	8	19	18
JIS 5K 32 FF 304 SS (JIS)	115	90	4	15	5
JPI Class 150 4 RF 304 SS (JIS)	229	190.5	8	19	24
JPI Class 150 3 RF 304 SS (JIS)	190	152.4	4	19	24
Westinghouse	155	127	4	11.5	14

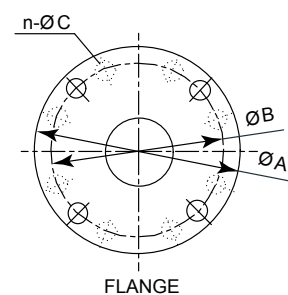

F2.1-1E.ai

2. ZR402G Separate type Zirconia Oxygen Analyzers, Converter

Unit : mm

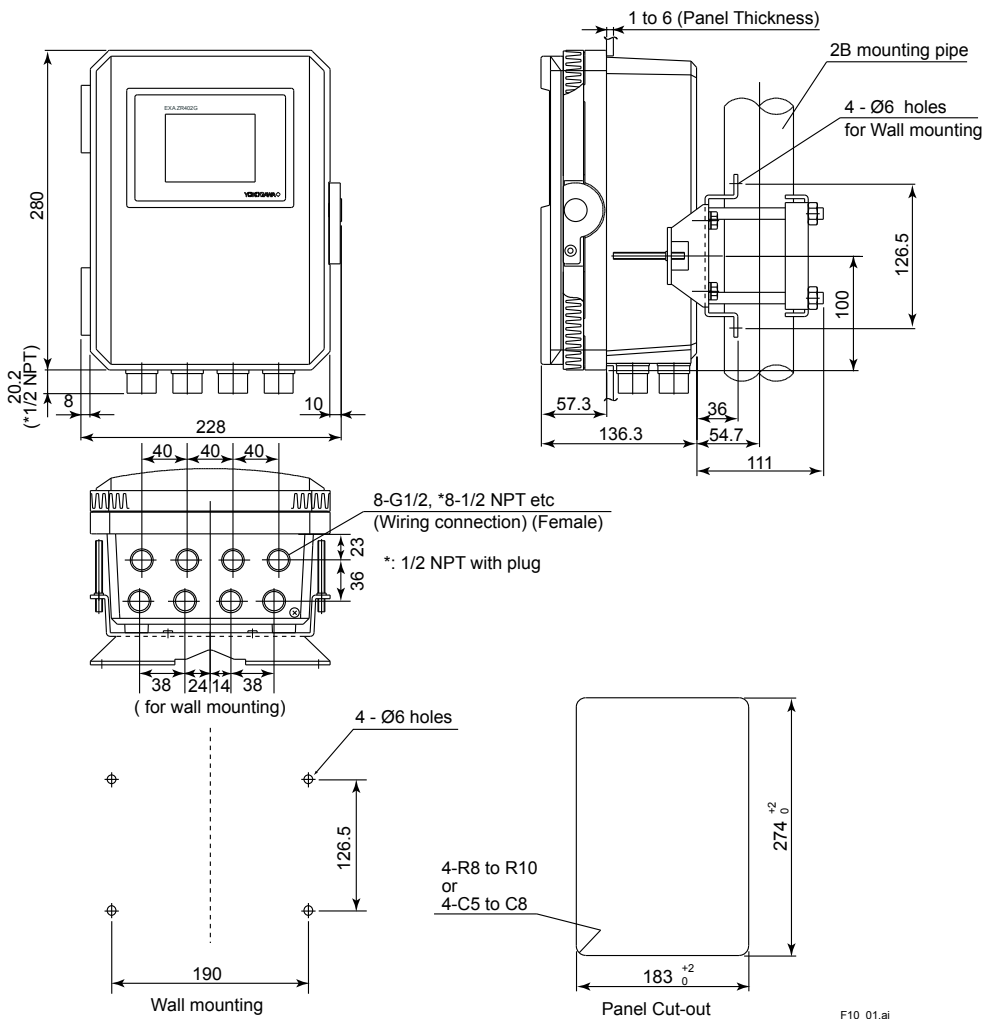

F10\_01.ai

●With sun shield hood (option code /H)

Unit : mm

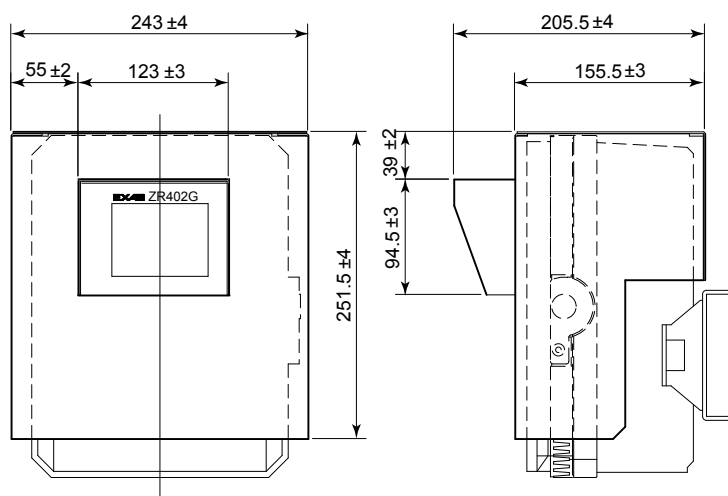

F11.ai

Material of HOOD : Aluminum



### 3. ZR202S Integrated type Explosion-proof Zirconia Oxygen Analyzers

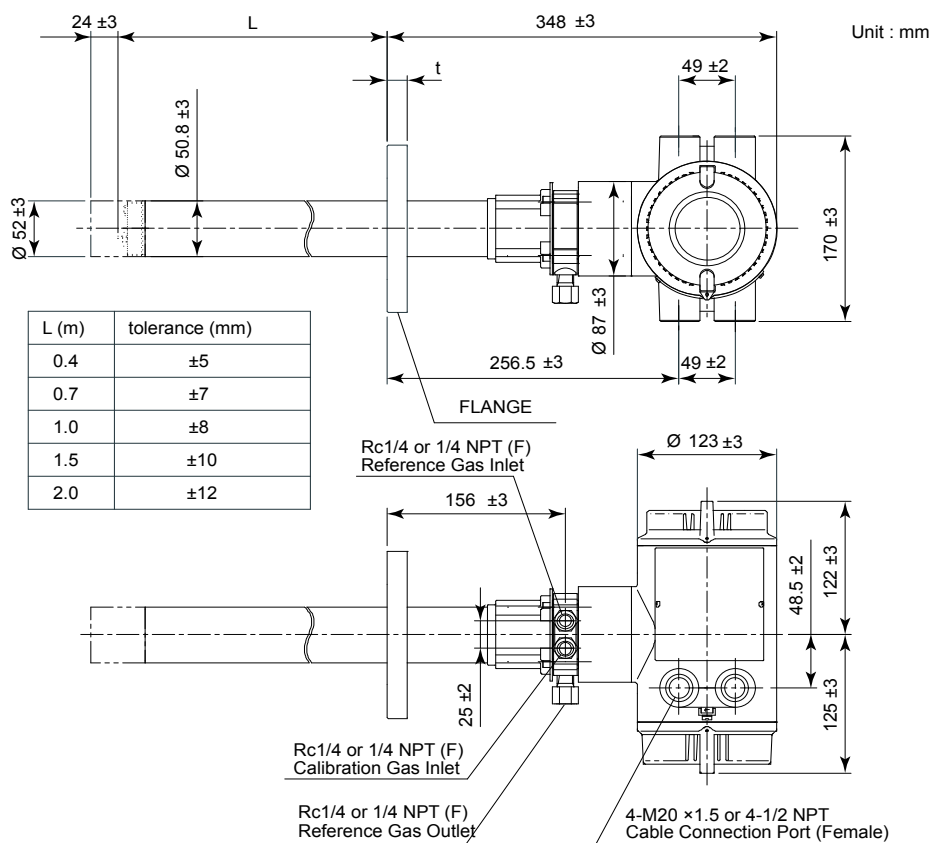

Flange	A	B	C	t
ANSI Class 150 2 RF 304 SS (JIS)	152.4	120.6	4 - Ø19	19
ANSI Class 150 3 RF 304 SS (JIS)	190.5	152.4	4 - Ø19	24
ANSI Class 150 4 RF 304 SS (JIS)	228.6	190.5	8 - Ø19	24
DIN PN10 DN50 304 SS (JIS)	165	125	4 - Ø18	18
DIN PN10 DN80 304 SS (JIS)	200	160	8 - Ø18	20
DIN PN10 DN100 304 SS (JIS)	220	180	8 - Ø18	20
JIS 5K 65 FF 304 SS (JIS)	155	130	4 - Ø15	14
JIS 10K 65 FF 304 SS (JIS)	175	140	4 - Ø19	18
JIS 10K 80 FF 304 SS (JIS)	185	150	8 - Ø19	18
JIS 10K 100 FF 304 SS (JIS)	210	175	8 - Ø19	18
JPI Class 150 4 RF 304 SS (JIS)	229	190.5	8 - Ø19	24
JPI Class 150 3 RF 304 SS (JIS)	190	152.4	4 - Ø19	24
Westinghouse	155	127	4 - Ø11.5	14

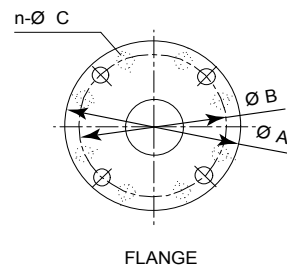

ZR202S-1.ai

●With sun shield hood (option code /H)

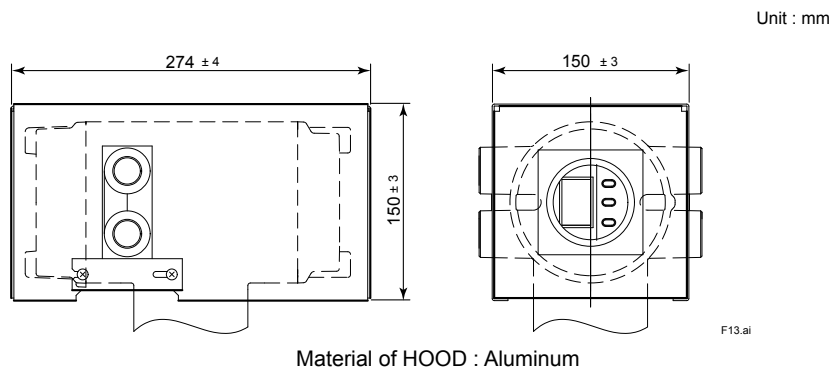

ZR202S Integrated type Explosion-proof Zirconia Oxygen Analyzers

With Automatic Calibration Unit (Horizontal Mount)

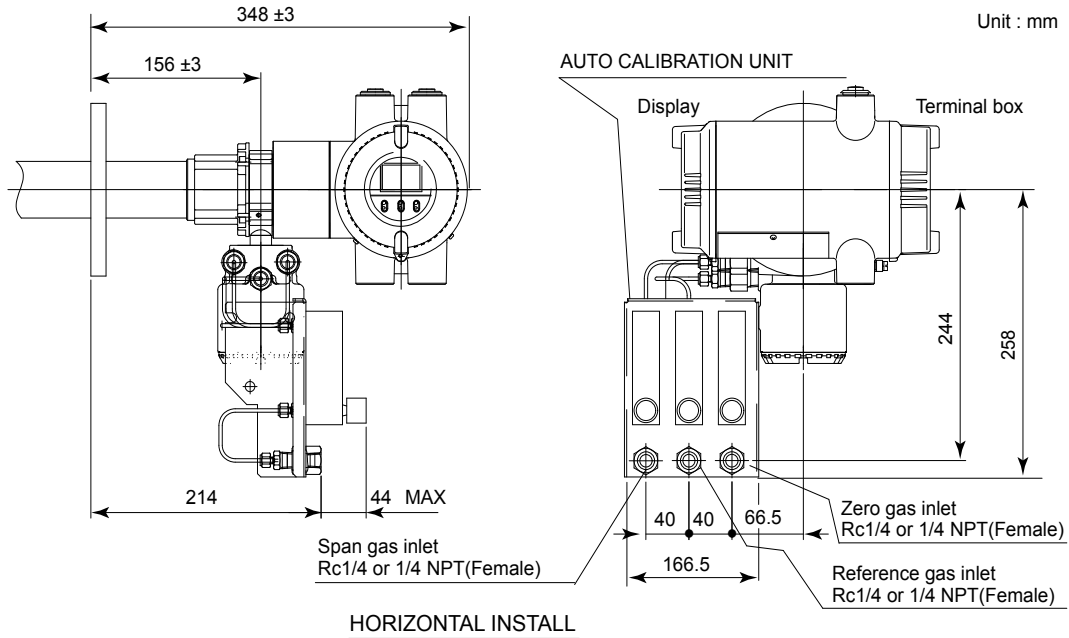

With Automatic Calibration Unit (Vertical Mount)

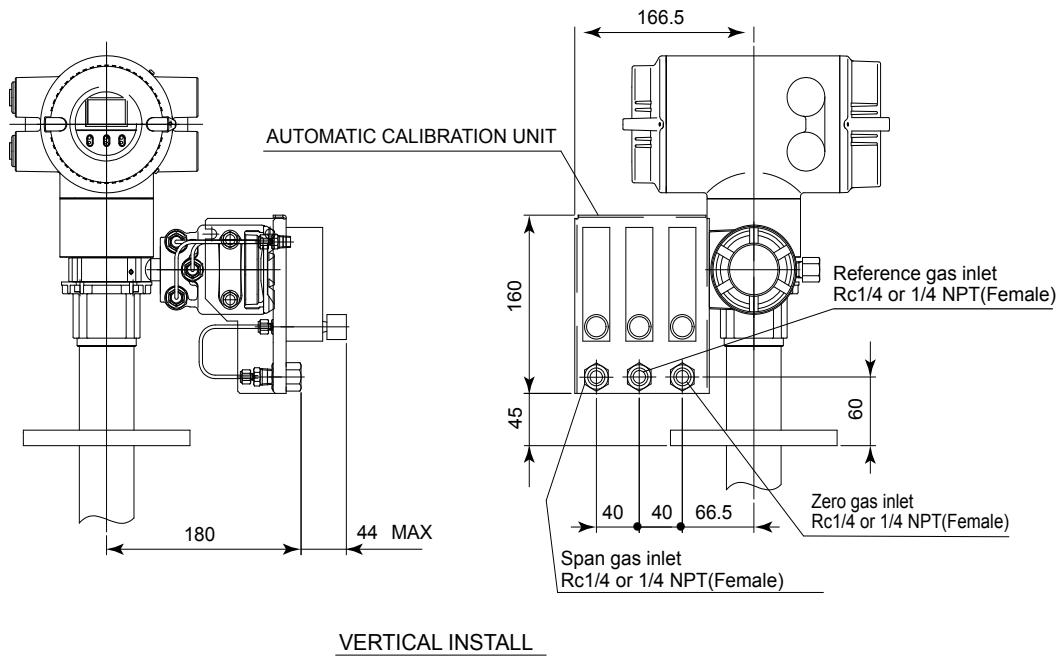

#### 4. ZO21P High Temperature Probe Adapter for separate type Explosion-proof Oxygen Analyzer

Unit: mm

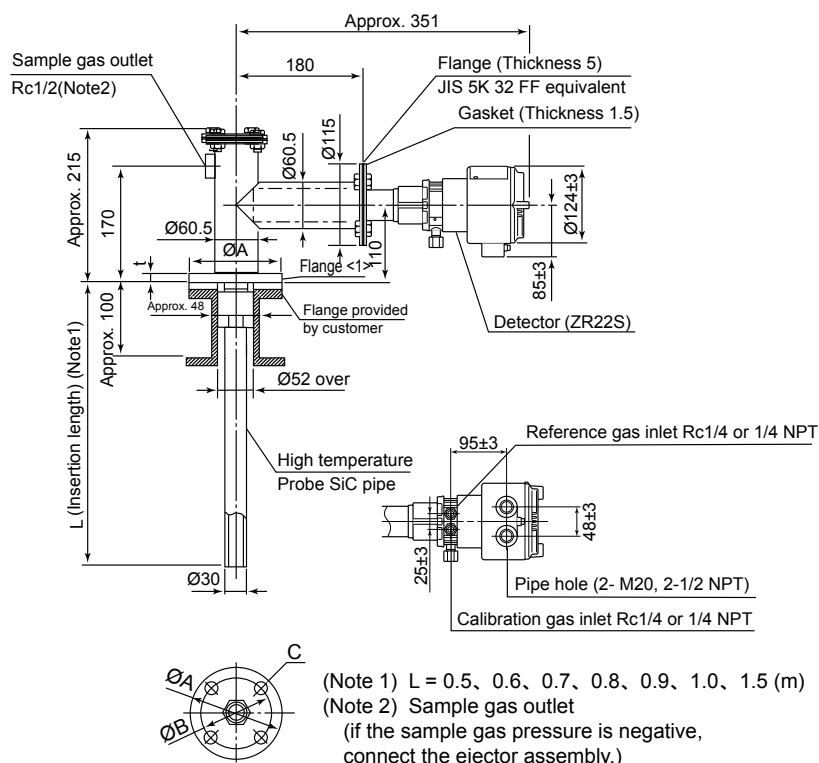

< > Flange	A	B	C	t
JIS 5K 50 FF 304 SS (JIS)	130	105	4 - Ø15	14
JIS 10K 65 FF 304 SS (JIS)	175	140	4 - Ø19	18
JIS 10K 80 FF 304 SS (JIS)	185	150	8 - Ø19	18
JIS 10K 100 FF 304 SS (JIS)	210	175	8 - Ø19	18
ANSI Class 150 2 1/2 RF 304 SS (JIS)	177.8	139.7	4 - Ø19	22.4
ANSI Class 150 3 RF 304 SS (JIS)	190.5	152.4	4 - Ø19	24
ANSI Class 150 4 RF 304 SS (JIS)	228.5	190.5	8 - Ø19	24
JPI Class 150 3 RF 304 SS (JIS)	190	152.4	4 - Ø19	24
JPI Class 150 4 RF 304 SS (JIS)	229	190.5	8 - Ø19	24
DIN PN10 DN50 A 304 SS (JIS)	165	126	4 - Ø18	18

F14.ai



8. ZA8F Flow setting unit for manual calibration

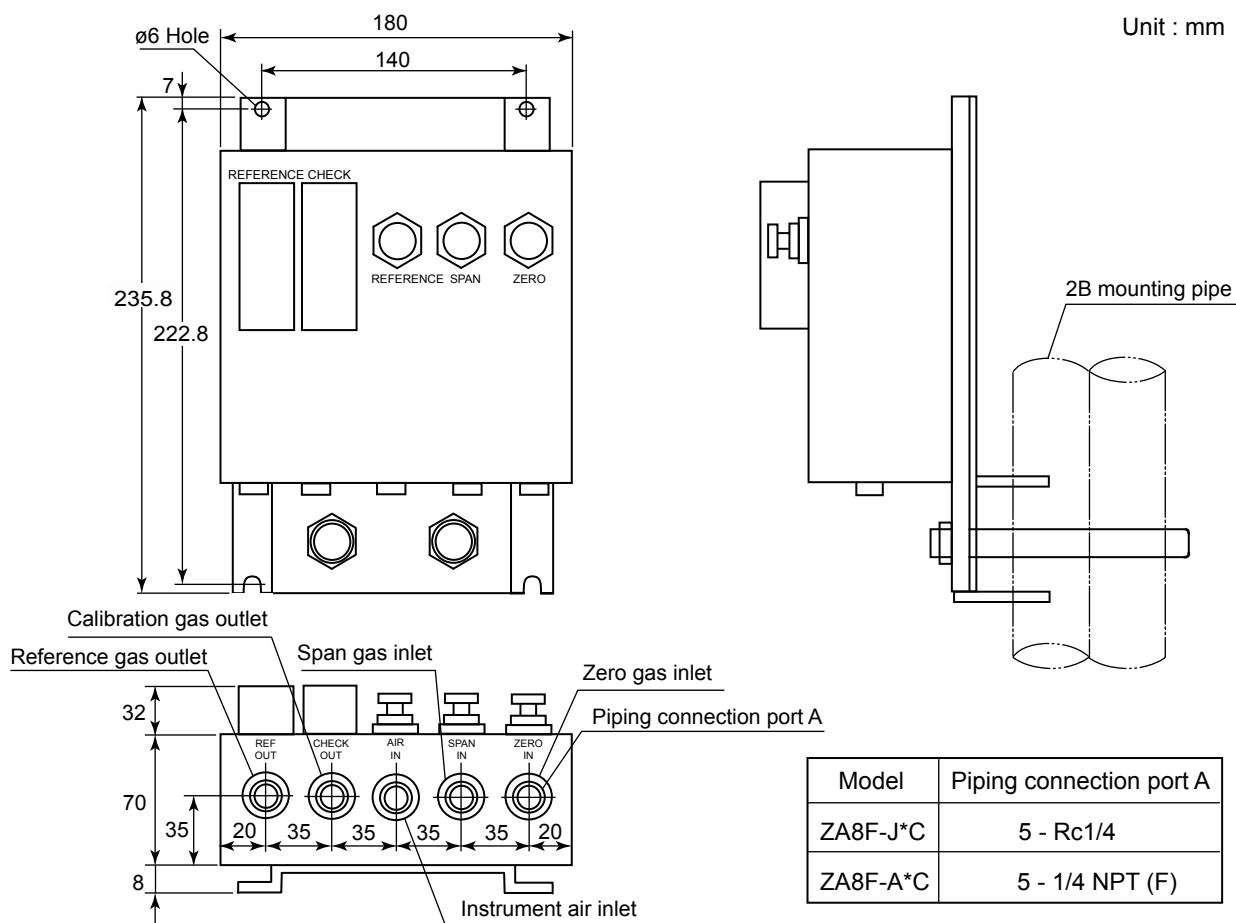

Weight : Approx. 2.3 kg

PIPING INSIDE THE FLOW SETTING UNIT

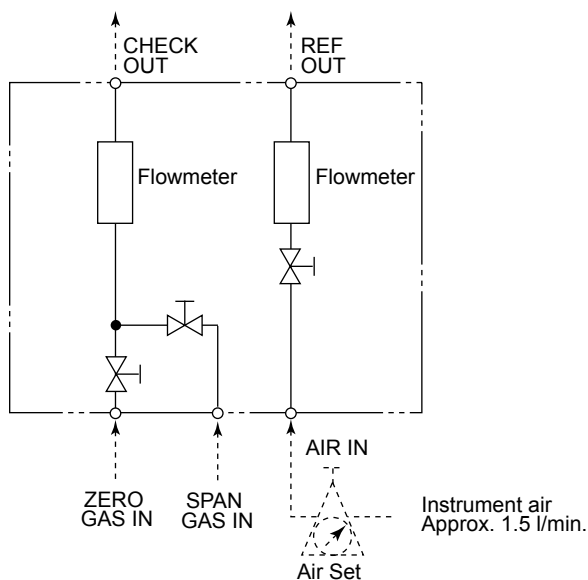

Air pressure ;  
 without check valve ; sample gas pressure + approx.50 kPaG  
 with check valve ; sample gas pressure + approx.150 kPaG

F2.6E.ai



### 9. ZR40H Automatic Calibration Unit for Separate type Analyzer

Unit: mm

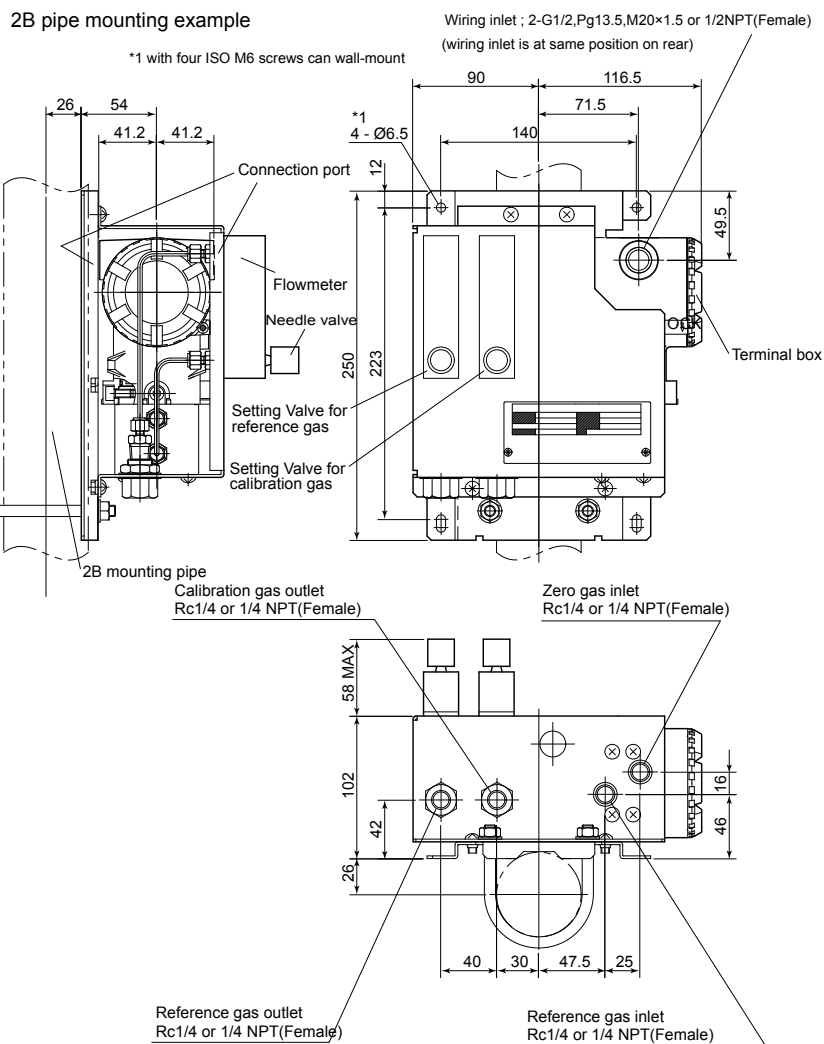

F21.ai

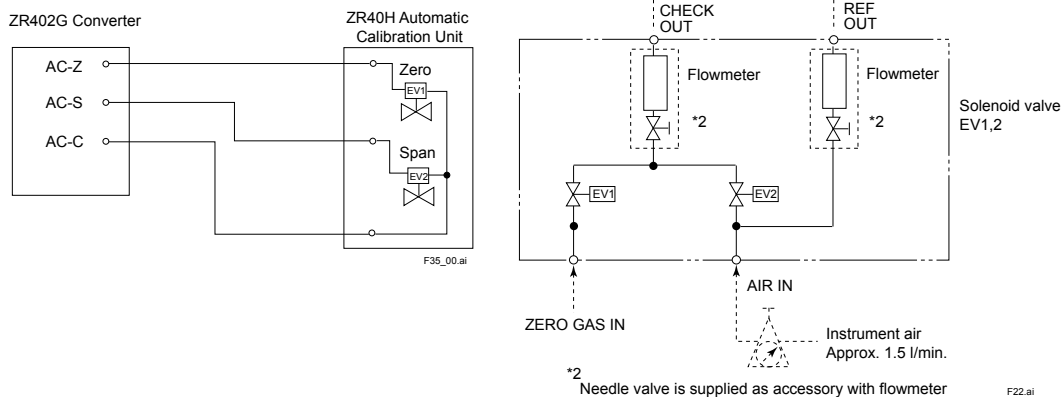

F22.ai

### 10. Automatic Calibration Unit for Integrated type Analyzer

When Automatic Calibration of (-A) or (-B) code is specified, Automatic Calibration Unit is installed in ZR202S.

Refer to the 20 Pages for the figure.

When (-N) is selected, Automatic Calibration Unit is not available.

### 11. L9852CB /G7016XH Stop Valve for Calibration gas line

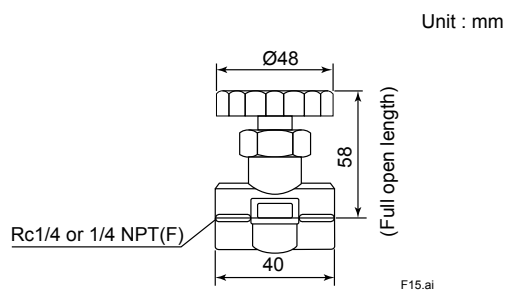

### 12. K9292DN /K9292DS Check Valve for Calibration gas line

K9292DN : Rc1/4(A), R1/4(B)

K9292DS : 1/4 NPT (Female)(A), 1/4 NPT(Male)(B)

Unit: mm

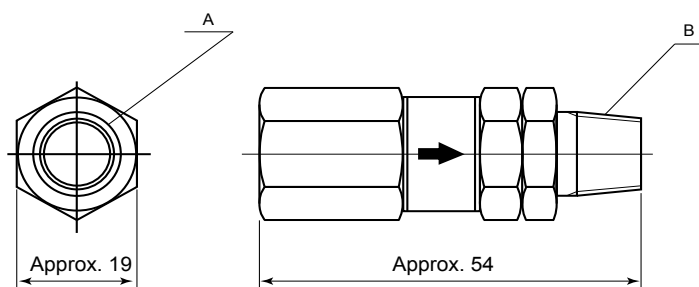

13. G7003XF/K9473XK, G7004XF /K9473XG Air Set

Unit : mm

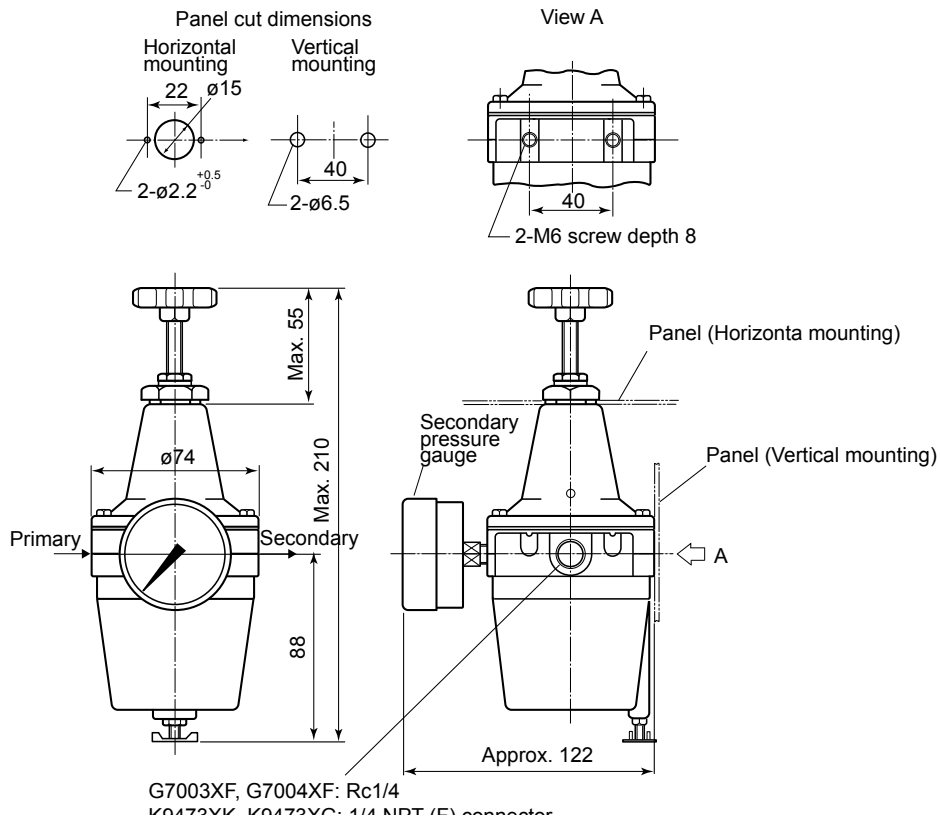

14. G7013XF/G7014XF Pressure Regulator for Gas Cylinder

Unit: mm

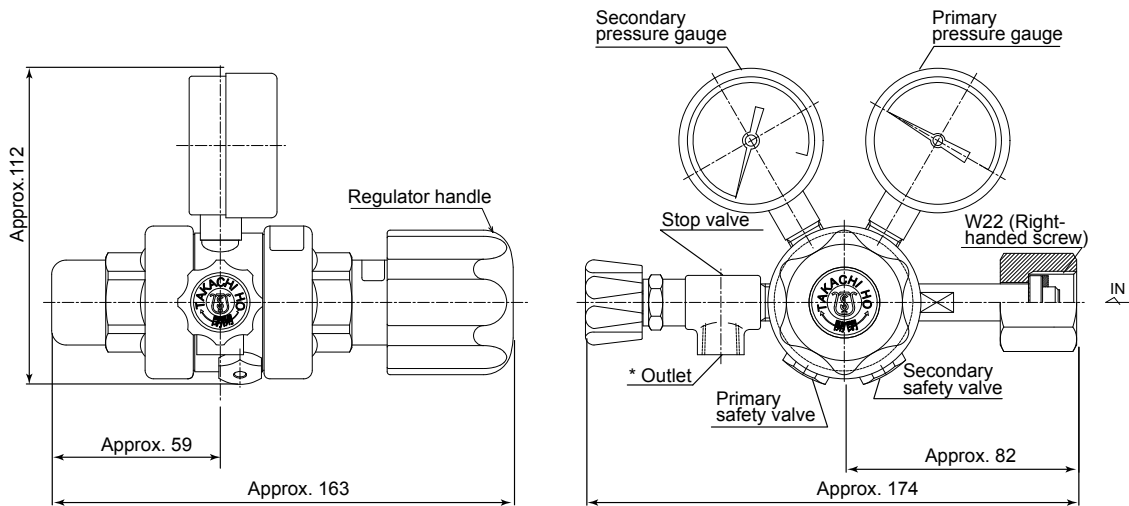

Part No.	*Outlet
G7013XF	Rc1/4
G7014XF	1/4 NPT (Female)

Regulator.ai

**WIRING CONNECTIONS**

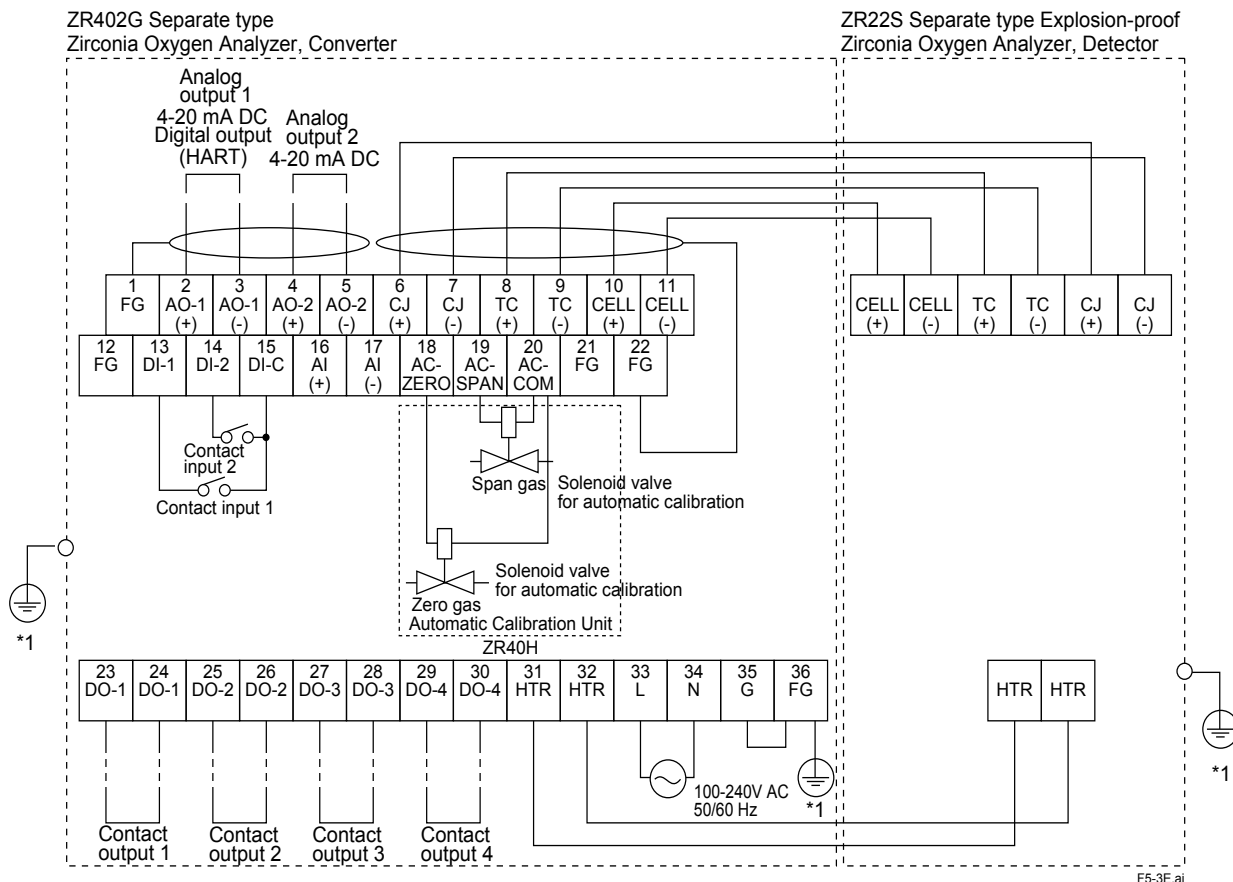

\*1 The ground wiring of the converter should be connected to either the protective ground terminal in the equipment or the ground terminal of the converter case.  
 Ground to earth, ground resistance: 100 Ω or less.

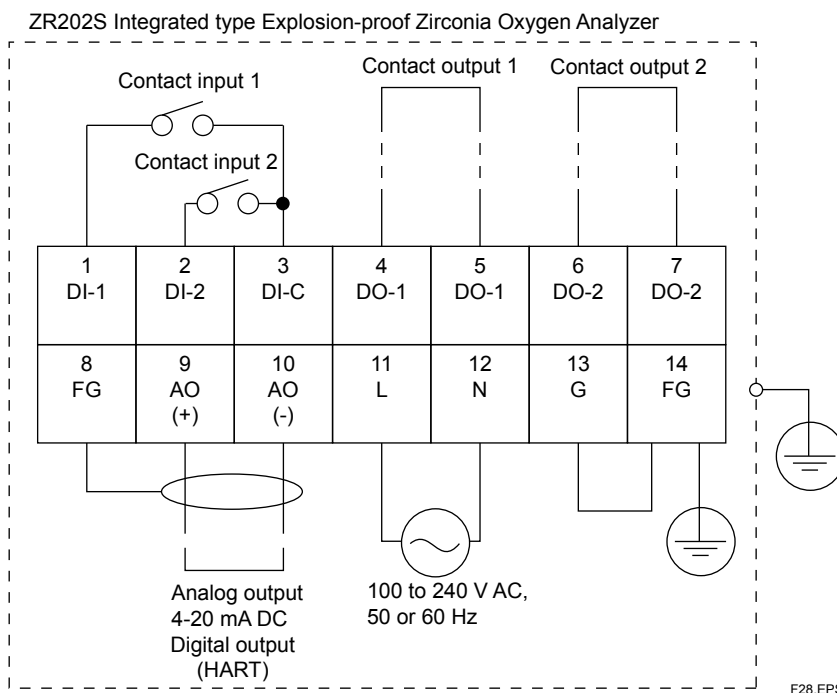

## Inquiry Sheet for Models ZR22S, ZR402G, and ZR202S Direct In Situ Zirconia Oxygen Analyzers

Please place checkmarks in the appropriate boxes and fill in the necessary information in the blanks.

### 1. General information

Customer \_\_\_\_\_  
 Destination of delivery \_\_\_\_\_ Type of analyzer :  Separate type  Integrated type  
 Plant name \_\_\_\_\_ Object :  indication  record  control  alarm  
 Measurement points \_\_\_\_\_ Fuel :  gas  oil  coal  \_\_\_\_\_  
 Power requirements \_\_\_\_\_ V AC \_\_\_\_\_ Hz

### 2. Process conditions

#### 2.1 Measurement gas components

2.2 Oxygen concentration	Nor.	Min.	Max.	<input type="checkbox"/> vol% O <sub>2</sub> ,	<input type="checkbox"/>
2.3 Temperature	Nor.	Min.	Max.	<input type="checkbox"/> °C,	<input type="checkbox"/>
2.4 Pressure	Nor.	Min.	Max.	<input type="checkbox"/> kPa,	<input type="checkbox"/>
2.5 Gas flow	Nor.	Min.	Max.	<input type="checkbox"/> m/sec,	<input type="checkbox"/>
2.6 Dust type, Size	Nor.	Min.	μm quantity	<input type="checkbox"/> g/Nm <sup>3</sup> ,	<input type="checkbox"/>
2.7 Corrosive gas	<input type="checkbox"/> No gas	<input type="checkbox"/> Gas	_____ , quantity _____	<input type="checkbox"/> ppm,	<input type="checkbox"/>
			_____ , quantity _____	<input type="checkbox"/> ppm,	<input type="checkbox"/>
2.8 Combustible gas	<input type="checkbox"/> No gas	<input type="checkbox"/> Gas	_____ , quantity _____	<input type="checkbox"/> ppm,	<input type="checkbox"/>
			_____ , quantity _____	<input type="checkbox"/> ppm,	<input type="checkbox"/>
2.9 Others	_____				

### 3. Installation site conditions

3.1 Ambient temperature 1. Around Probe temp. from \_\_\_\_\_ to \_\_\_\_\_ °C, 2. Around Converter temp. from \_\_\_\_\_ to \_\_\_\_\_ °C  
 3.2 Vibration  No vibration  Vibration \_\_\_\_\_  
 3.3 1 Probe installation location  Furnace  Stack  Others \_\_\_\_\_  
 2 Probe position  Horizontal  Vertical  Others \_\_\_\_\_  
 Indoor  Outdoor  Covered  
 3 Probe insertion length (m) (Note)  0.15,  0.4,  0.7,  1.0,  1.5,  2.0  
 4 Flange  DIN \_\_\_\_\_  ANSI \_\_\_\_\_  Others \_\_\_\_\_  
 3.4 Converter location  Indoor  Outdoor  Covered (under roof)  
 3.5 Cable length between probe and converter \_\_\_\_\_ meters  
 3.6 Calibration method  Manual  Automatic

### 4. Quotation data

Quotation		Quantity	Description
Probe	ZR22S Separate type Explosion-proof Zirconia Oxygen Analyzer, Detector		Refer to the Probe Configuration for probe selection.
	ZO21P-H High Temperature Probe Adapter		
	E7046EC /E7046EN Ejector Assembly for high temperature.		
	ZO21R Probe Protector for Oxygen Analyzer (Option)		
ZR402G Separate type Zirconia Oxygen Analyzer, Converter			
ZR202S Integrated type Explosion-proof Zirconia Oxygen Analyzer			
ZO21S Standard Gas Unit			Select any one of Model ZO21S, ZA8F, ZR40H.
ZA8F Flow Setting Unit			
ZR40H Automatic Calibration Unit			
L9852CB /G7016XH Stop Valve			Not required if probe options are specified.
K9292DN /K9292DS Check Valve			
G7003XF/K9473XK, G7004XF/K9473XG Air Set			
G7013XF /G7014XF Pressure Regulator			
ZR22A, ZR202A Heater Assembly (Spare Parts)			

T22.ai