

# General Specifications

## ADMAG TI Series AXG Magnetic Flowmeter



### GS 01E22A01-01EN

#### ■ GENERAL DESCRIPTION

The ADMAG TI (Total Insight) series AXG magnetic flowmeter is a high-quality and highly reliable product developed based on years of experience and achievement, such as enhancement of application by our proprietary dual frequency excitation method.

The AXG magnetic flowmeter is ideal for industrial process lines like oil & gas, chemical, pulp & paper, food & beverage, or metal & mining applications. With outstanding reliability and ease of operation and maintenance, developed on decades of field-proven experience, the AXG will increase user benefits while reducing total cost of ownership.

The sizes are available from 2.5 to 500 mm (0.1 to 20 in.). For lining, fluorocarbon PFA lining or ceramics tube which can be applied to severe applications can be selected. Process connection also supports various specifications such as ASME, EN, AS, and JIS.

Note: For AXFA11G remote transmitter, read general specifications (GS 01E20C01-01E).



Integral Flowmeter



Remote Transmitter



Remote Sensor

#### ■ FEATURES

##### ● Stable Measurement

Our own dual frequency excitation method realizes stable flow measurement even under high flow noise in the fluid with highly concentrated slurry.

##### ● Multiple Inputs and Outputs

Maximum four inputs/outputs of current, pulse, and status signals can be selected. Mass or calorie calculation using temperature input is available.

##### ● Improved Operation and Monitoring Function

Operation authority level setting for ensuring safety, process data trend display, display backlight flashing (Squawk) function, and data store / restore function with display unit internal memory or microSD card are available.

##### ● Improved Maintainability

Diagnostic functions that contribute to preventive maintenance of the plant are installed. Diagnosis of the device (verification function) that can be executed without demounting from piping, detection of the process condition by monitoring the flow noise and electric conductivity of the fluid, electrode insulation deterioration diagnosis, electrode adhesion diagnosis, and wiring connection diagnosis are available.

#### CONTENTS

GENERAL DESCRIPTION	P.1
FEATURES	P.1
GENERAL	P.2
CONSTRUCTION	P.2
- Use, Construction	P.2
- Process Connection, Wetted Part, Lining Material	P.3
- Electrode Material, Electrode Construction	P.3
- Grounding Device Material	P.3
- Grounding Device Construction	P.3
- Gasket Material	P.3
- Non-wetted Part Material	P.4
- Coating, Cable Entry, Wiring Terminal	P.5
- Mounting, Grounding	P.5
- Limitations on Specification Selection	P.5
FUNCTIONS	P.8
CONFORMITY STANDARDS	P.11
PERFORMANCE	P.12
NORMAL OPERATING CONDITIONS	P.14
CAUTIONS ON SELECTION AND INSTALLATION	P.17
MODEL AND SUFFIX CODE	P.21
OPTIONAL CODE	P.36
ACCESSORIES	P.46
TERMINAL CONFIGURATION	P.46
DIMENSIONAL DRAWINGS	P.48
SIZING DATA	P.79
ORDERING INFORMATION	P.80
RELATED INSTRUMENTS	P.83
REFERENCE STANDARD	P.83
TRADEMARKS	P.83

## ■ GENERAL

### Measuring Principal:

By applying the occurrence of electromotive force proportional to the flow velocity when fluid moves in the magnetic field, the flowmeter can measure the flow velocity of conductive liquid. It calculates the instantaneous flow rate, integrated flow rate, etc. from the measured flow velocity.

### System Configuration:

The flowmeter consists of a sensor that detects the flow velocity and a transmitter that amplifies, and converts the signal.

Structurally, there is an integral type (integrated structure of a sensor and a transmitter), and remote type (separated structure of a sensor and a transmitter).

In the remote type, the signal cable for the flow signal and the excitation cable for the coil excitation are added to the constituent elements.

### Main Element of Sensor:

#### Wetted Part:

Lining (\*1), Electrodes, Grounding Devices (\*2), Adapters for hygienic.

\*1: including ceramics tube.

\*2: grounding ring plate, grounding ring electrode, built-in grounding electrode

Note: Grounding devices are for taking the reference electric potential from the process fluid in measuring the electromotive force, and are fixed (or built-in) at two locations, upstream and downstream of the flow. They are unnecessary when the reference potential is taken from customer piping. For details of grounding, read "Cautions on Selection and Installation".

#### Non-wetted Part:

Flanges, Housing, Excitation coil, Measuring pipe (excluding ceramics tube)

### Main Element of Transmitter:

Display unit, Setting keys, Amplifier unit (including I/Os and power supply unit)

## ■ CONSTRUCTION

### Use:

Use	Specification
General-purpose	Non explosion protection for the use in non-hazardous area. Applicable to Integral Flowmeter, Remote Sensor, or Remote Transmitter. IP Protection Grade: IP66/67, Type 4X (CSA)
Submersible	Temporary submersion is possible. Applicable to Remote Sensor only. Note: Urethane resin potting is applied in the terminal box of a remote sensor. Signal and excitation cables (when optional code L□□□ is not selected, cable length is each 30 m) are pre-wired and waterproof glands with union joints are attached at factory. Performance: Conforms to continuous immersion under the following test condition. Test Condition: 50 m below the surface of the water, equivalent to 0.5 MPa hydraulic pressure, for one month. In case of bad condition such as sewage and seawater, this does not apply. Also, waterproof and protect the cable separately by conduit piping, etc.
Hygienic	Integrated piping adapters with hygienic standards. Applicable to Integral Flowmeter, or Remote Sensor. IP Protection Grade: IP66/67, Type 4X (CSA)

### Construction:

#### Integral Type:

A flowmeter in integrated structure of a sensor and a transmitter.

#### Remote Type:

A flowmeter in separated structure of a sensor and a transmitter, which are connected by a signal cable and an excitation cable. The excitation cable is to be supplied by customer except for submersible.

Combined Transmitter (\*1) (\*2):

Remote Sensor Size	Remote Transmitter
2.5 to 400 mm (0.1 to 16 in.)	AXG4A, AXFA11G
500 mm (20 in.)	AXFA11G

\*1: When changing the combination transmitter, readjustment of the meter factor by actual flow calibration is necessary to ensure accuracy.

\*2: For AXFA11G remote transmitter, read general specifications (GS 01E20C01-01E).

#### Maximum Cable Length:

100 m (328 ft) for AXG4A remote transmitter

200 m (656 ft) for AXFA11G remote transmitter

**Process Connection:**

Available process connections are wafer, flange, union joint (screw type, welding type), clamp, union, and welded joint type. For the linings and size ranges that can be combined with these connections, read "Limitations on Specification Selection".

Wafer:

- ASME Class 150, Class 300
- EN PN10, PN16, PN40
- JIS F12, 10K, 20K
- JPI Class 150

Flange:

- ASME Class 150, Class 300, Class 600
- EN PN10, PN16, PN40
- JIS F12, 10K, 20K
- JPI Class 150
- AS Table D, Table E

Union Joint:

- Screw Type:
  - 1/4 NPT (for sizes 2.5 to 5 mm (0.1 to 0.2 in.))
  - 3/8 NPT (for size 10 mm (0.4 in.))
  - R 1/4 (for sizes 2.5 to 5 mm (0.1 to 0.2 in.))
  - R 3/8 (for size 10 mm (0.4 in.))
- Welding Type:
  - Outer Diameter of Welding Union Joint:
    - 18.5 mm / 0.73 in. (for sizes 2.5 to 5 mm (0.1 to 0.2 in.))
    - 22.5 mm / 0.89 in. (for size 10 mm (0.4 in.))

Clamp:

- Tri-Clamp
- DIN 32676 Clamp
- ISO 2852 / SMS 3016 Clamp
- ISO 2852 Clamp (for JIS G3447 Piping)

Union:

- DIN 11851 Union
- ISO 2853 Union
- SMS 1145 Union (Open groove packing type)
- ISO 2853 Union (for JIS G3447 Piping)

Butt Weld Joint:

- DIN 11850 Piping Butt Weld Joint
- ISO 2037 Piping Butt Weld Joint
- JIS G3447 Piping Butt Weld Joint

**Wetted Part:**

**Lining Material:**

- Fluorocarbon PFA, Ceramics (\*)
- \* : Alumina ceramics (99.8%)

**Electrode Material:**

- Stainless steel 316L, Nickel alloy (\*), Platinum-Iridium, Tantalum, Titanium, Tungsten carbide, Platinum-Alumina cermet
- \* : ASTM B574 UNS N10276 or ASME SB-574 UNS N10276

**Electrode Construction:**

- PFA Lining:
  - External insertion type or internal insertion type (\*)
  - \* : Internal insertion type is for models with Hygienic, size 500 mm (20 in.), or ASME Class 600 flange high pressure type.
- Ceramics Tube:
  - Electrode integrally sintered type (Platinum-Alumina Cermet)

**Grounding Device Material:**

- Grounding Ring Plate:
  - Stainless steel 316L, Nickel alloy (\*), Titanium
  - \* : ASTM B575 UNS N10276 or ASME SB-575 UNS N10276
- Grounding Ring Electrode:
  - Platinum-Iridium, Tantalum
- Built-in Grounding Electrode:
  - Platinum-Iridium, Tantalum

**Grounding Device Construction:**

- Grounding Ring Plate:
  - Ring flat plate, with mounting bracket
- Grounding Ring Electrode:
  - Electrode is inserted into ring-shaped short pipe with PFA lining, with mounting bracket
- Built-in Grounding Electrode:
  - Electrode is inserted on the inner surface of the measuring pipe

**Gasket Material:**

The following is a description of the material of gaskets, which are supplied with flowmeter, to be used between the sensor pipe and grounding rings, or the customer pipe flanges. This includes if the gaskets are necessary or not, or if some gaskets should be supplied by customer. For details of gaskets, read "Cautions on Selection and Installation" and "Optional Code".

**PFA Lining:**

General-purpose, Submersible (excluding ASME Class 600 flange high pressure type):

- Standard:
  - None (not necessary), or supplied by customer
- Optional (for plastic piping):
  - GA: Fluororubber
  - GC: Acid-resistant fluororubber
  - GD: Alkali-resistant fluororubber

ASME Class 600 flange high pressure type:

- Standard: Fluororubber (FKM) (O-ring)

Hygienic:

- 1: Gasket A
- 2: Adapter
- When selecting optional code W2
- 3: Gasket B
- 4: Clamp
- 5: Ferrule
- 6: Sleeve
- 7: Nut

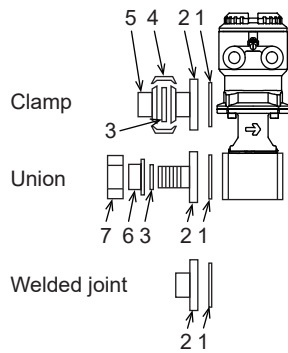

F01.ai

**Gasket A:**

- Standard: Ethylene propylene diene rubber (EPDM)
- Optional:
  - GH: Silicone rubber

**Gasket B:**

- Optional:
  - W2:
    - Sizes 15 to 100 mm (0.5 to 4 in.): Ethylene propylene diene rubber (EPDM)
    - Sizes 125 mm (5 in.): Silicone rubber
  - W2 and GH: Silicone rubber

**Ceramics Tube:**

- Standard:
  - Fluororesin with ceramic fillers (Valqua #7020)
- Optional (for plastic piping):
  - GA: Fluororubber
  - GC: Acid-resistant fluororubber
  - GD: Alkali-resistant fluororubber
- Optional (for metal piping):
  - GF: Fluororesin with alkali-resistant carbons

**Customer Pipe:**

- Standard:
  - None (supplied by customer)
- Optional (for wafer type, with bolts, nuts, and gaskets):
  - BSC: Chloroprene rubber (CR)
  - BSF: PTFE-sheathed non-asbestos joint sheet

**Adapters for Hygienic:**

- Process Connection (Clamp):
  - HJA: Stainless steel F304
  - Optional W2 (Hygienic Connection Parts):
    - Clamp: Stainless steel SCS13 (\*1)
    - Ferrule:
      - Size 15 mm (0.5 in.): Stainless steel 316L
      - Sizes 25 to 125 mm (1 to 5 in.): Stainless steel 304
  - HJB: Stainless steel F316L
  - Optional W2 (Hygienic Connection Parts):
    - Clamp: Stainless steel SCS13 (\*1)
    - Ferrule: Stainless steel 316L
  - HAB, HDB, HKB: Stainless steel F316L
- Process Connection (Union):
  - JJA: Stainless steel F304
  - Optional W2 (Hygienic Connection Parts):
    - Nut: Stainless steel 304
    - Sleeve: Stainless steel 304
  - JJB: Stainless steel F316L
  - Optional W2 (Hygienic Connection Parts):
    - Nut: Stainless steel 304
    - Sleeve: Stainless steel F316L
  - JDB, JKB, JSB: Stainless steel F316L
- Process Connection (Butt Weld Joint):
  - KJA: Stainless steel F304
  - KJB, KDB, KKB: Stainless steel F316L

\*1: JIS standard casting material

**Non-wetted Part Material:**

- Sensor Terminal Box:
  - Low copper aluminum alloy EN AC-43400
- Transmitter Housing:
  - Low copper aluminum alloy EN AC-43400
- Sensor Housing:

Size	Material
2.5 to 15 mm (0.1 to 0.5 in.)	Stainless steel SCS11 (*1)
25 to 125 mm (1 to 5 in.)	Stainless steel 304
150 to 500 mm (6 to 20 in.)	Carbon steel SPCC (*2)

\*1: JIS standard material  
\*2: JIS standard or JIS standard-based material

- Mini-flange (subject to pressure in wafer type):
  - PFA Lining

Size	Material
150 to 200 mm (6 to 8 in.)	Carbon steel A105 (*3)

Note: In the wafer type other than the above, there is no mini flange because the measuring pipe and the connecting part have a one-piece casting structure.

- Flange:

Process Connection Code	Material
B□□	Stainless steel F304
D□□	
E□□	
P□□	Stainless steel F316
C□□	Carbon steel A105 (*3)

\*3: ASTM standard forged material

- Measuring Pipe:

- PFA Lining (excluding Hygienic, or ASME Class 600 flange high pressure type)

Size	Material
2.5 to 15 mm (0.1 to 0.5 in.)	Stainless steel SCS13 (*4)
25 to 125 mm (1 to 5 in.)	Stainless steel CF8 (*5)
150 to 500 mm (6 to 20 in.)	Stainless steel 304

- PFA Lining (ASME Class 600 flange high pressure type)

Size	Material
25 to 100 mm (1 to 4 in.)	Stainless steel 304

- PFA Lining (for Hygienic)

Size	Material
15 to 25 mm (0.5 to 1 in.)	Stainless steel SCS13 (*4)
32 to 125 mm (1.25 to 5 in.)	Stainless steel CF8 (*5)

\*4: JIS standard casting material  
\*5: ASME standard casting material  
Note: Read "Lining Material" for ceramics tube, which is a wetted part material.

**Coating:**

Coating specification depends on "Use" specification. For General-purpose, either standard coating or rugged coating can be selected.

For Submersible, Hygienic, standard coating can be selected.

Standard coating for Submersible is for its own specification.

General-purpose (Integral Flowmeter, Remote Sensor and Transmitter):

Standard Coating:

Coated Part	Coating Specification
Sensor housing	Polyurethane resin solvent coating, or no coating (*1)
Sensor flanges (for flange type)	
Sensor terminal box (for remote type, incl. cover)	Urethane curing type polyester resin powder coating
Transmitter housing (incl. cover)	

Rugged Coating (\*2):

Coated Part	Coating Specification
Sensor housing	Epoxy and polyurethane resin solvent coating, or no coating (*1)
Sensor flanges (for flange type)	
Sensor terminal box (for remote type, incl. cover)	Epoxy and polyurethane resin solvent coating
Transmitter housing (incl. cover)	

Submersible (Remote Sensor):

Standard Coating:

Coated Part	Coating Specification
Sensor housing	Non-tar epoxy resin solvent coating
Sensor flanges	
Sensor terminal box (incl. cover)	

Hygienic (Integral Flowmeter, and Remote Sensor):

Standard Coating:

Coated Part	Coating Specification
Sensor housing	No coating
Adapter for piping	
Sensor terminal box (for remote type, incl. cover)	Urethane curing type polyester resin powder coating
Transmitter housing (incl. cover)	

\*1: No coating for General-purpose with stainless steel flanges in sizes 2.5 to 125 mm (0.1 to 5 in.). Coating is done to sizes 150 mm (6 in.) and more, or to carbon steel flanges.

\*2: Rugged coating is for applications which need salt tolerance resistance, alkali resistance, acid resistance, and/or weather resistance. Epoxy resin undercoating twice and polyurethane resin overcoating once are performed to the same area as standard coating.

Coating Color:

General-purpose, Hygienic:

Mint green (RAL color number 190 30 15)

Submersible:

Black (close to RAL color number 9011)

**Cable Entry:**

JIS G1/2 female

ASME 1/2 NPT female

ISO M20 x 1.5 female

Cable Entry Direction:

For Integral Flowmeter and Remote Sensor, the cable entry direction can be specified from +90, +180, or -90 degree rotation when optional code RH is ordering, and also can be changed by customer after delivery. However, it can not be changed after delivery when Submersible, or district heating and cooling / condensation-proof use (optional code DHC) is selected.

**Wiring Terminal:**

Intra-system Connection Part (\*1):

M4 Screw type

Extra-system Connection Part (\*2):

M4 Screw or Clamp type

\*1: Connections between Remote Sensor and Remote Transmitter for flow signal and excitation current.

\*2: Connections at Integral Flowmeter and Remote Transmitter for input/output signals and power supply.

**Mounting:**

Remote Transmitter: 2-inch pipe mounting

**Grounding:**

Grounding Resistance: 10 Ω or less

Note: When the built-in lightning protector is not required, grounding resistance 100 Ω or less can be applied.

**Limitations on Specification Selection:**

There are following limitations on the combination of specifications. For notes related to applications, read "Cautions on Selection and Installation".



• Size Range by Lining and Process Connection

**PFA Lining:**

Process Connection	Size Range	Process Connection Code
<b>Wafer:</b>		
ASME Class 150	2.5 to 200 mm (0.1 to 8 in.)	AA1
ASME Class 300	2.5 to 200 mm (0.1 to 8 in.)	AA2
EN PN10	200 mm (8 in.)	AE1
EN PN16	65 to 200 mm (2.5 to 8 in.)	AE2
EN PN40	2.5 to 50 mm (0.1 to 2 in.)	AE4
JIS F12	80 to 200 mm (3 to 8 in.)	AG1
JIS 10K	2.5 to 200 mm (0.1 to 8 in.)	AJ1
JIS 20K	2.5 to 200 mm (0.1 to 8 in.)	AJ2
JPI Class 150	2.5 to 200 mm (0.1 to 8 in.) (32, 65, and 125 mm (1.25, 2.5, and 5 in.) are not available.)	AP1
<b>Flange (Stainless Steel F304):</b>		
ASME Class 150	2.5 to 500 mm (0.1 to 20 in.)	BA1
ASME Class 300	2.5 to 300 mm (0.1 to 12 in.)	BA2
ASME Class 600	25 to 100 mm (1 to 4 in.) (32, and 65 mm (1.25, and 2.5 in.) are not available.)	EA4
EN PN10	200 to 500 mm (8 to 20 in.)	BE1
EN PN16	65 to 300 mm, and 500 mm (2.5 to 12 in., and 20 in.)	BE2
EN PN40	2.5 to 50 mm (0.1 to 2 in.)	BE4
JIS F12	80 to 400 mm (3 to 16 in.)	BG1
JIS 10K	2.5 to 400 mm (0.1 to 16 in.)	BJ1
JIS 20K	2.5 to 300 mm (0.1 to 12 in.)	BJ2
JPI Class 150	2.5 to 400 mm (0.1 to 16 in.) (32, 65, and 125 mm (1.25, 2.5, and 5 in.) are not available.)	BP1
EN PN40 (Nominal Size 10 mm)	2.5 to 10 mm (0.1 to 0.4 in.)	DE4
JIS 10K (Nominal Size 10 mm)	2.5 to 10 mm (0.1 to 0.4 in.)	DJ1
JIS 20K (Nominal Size 10 mm)	2.5 to 10 mm (0.1 to 0.4 in.)	DJ2
<b>Flange (Stainless Steel F316):</b>		
ASME Class 150	2.5 to 400 mm (0.1 to 16 in.) (32, 65, and 125 mm (1.25, 2.5, and 5 in.) are not available.)	PA1
ASME Class 300	2.5 to 300 mm (0.1 to 12 in.) (32, 65, and 125 mm (1.25, 2.5, and 5 in.) are not available.)	PA2
EN PN10	200 to 400 mm (8 to 16 in.)	PE1
EN PN16	80 to 300 mm (3 to 12 in.) (125 mm (5 in.) is not available.)	PE2
EN PN40	2.5 to 50 mm (0.1 to 2 in.) (32 mm (1.25 in.) is not available.)	PE4
JIS 10K	2.5 to 400 mm (0.1 to 16 in.) (32, 65, and 125 mm (1.25, 2.5, and 5 in.) are not available.)	PJ1

**PFA Lining:**

Process Connection	Size Range	Process Connection Code
<b>Flange (Carbon Steel):</b>		
ASME Class 150	50 to 500 mm (2 to 20 in.)	CA1
ASME Class 300	50 to 300 mm (2 to 12 in.)	CA2
EN PN10	200 to 500 mm (8 to 20 in.)	CE1
EN PN16	65 to 300 mm, and 500 mm (2.5 to 12 in., and 20 in.)	CE2
EN PN40	50 mm (2 in.)	CE4
JIS F12	80 to 400 mm (3 to 16 in.)	CG1
JIS 10K	50 to 400 mm (2 to 16 in.)	CJ1
JIS 20K	50 to 300 mm (2 to 12 in.)	CJ2
AS Table D	50 to 400 mm (2 to 16 in.) (65, and 125 mm (2.5, and 5 in.) are not available.)	CS1
AS Table E	50 to 300 mm (2 to 12 in.) (65, and 125 mm (2.5, and 5 in.) are not available.)	CS2
<b>Clamp (Stainless Steel F304):</b>		
ISO 2852 Clamp (for JIS G3447 Piping)	15 to 125 mm (0.5 to 5 in.)	HJA
<b>Clamp (Stainless Steel F316L):</b>		
ISO 2852 Clamp (for JIS G3447 Piping)	15 to 125 mm (0.5 to 5 in.)	HJB
Tri-Clamp	15 to 100 mm (0.5 to 4 in.) (32 mm (1.25 in.) is not available.)	HAB
DIN 32676 Clamp	15 to 125 mm (0.5 to 5 in.)	HDB
ISO 2852 / SMS 3016 Clamp	15 to 125 mm (0.5 to 5 in.)	HKB
<b>Union (Stainless Steel F304):</b>		
ISO 2853 Union (for JIS G3447 Piping)	25 to 100 mm (1 to 4 in.)	JJA
<b>Union (Stainless Steel F316L):</b>		
DIN 11851 Union	15 to 125 mm (0.5 to 5 in.)	JDB
ISO 2853 Union (for JIS G3447 Piping)	25 to 100 mm (1 to 4 in.)	JJB
ISO 2853 Union	15 to 100 mm (0.5 to 4 in.)	JKB
SMS 1145 Union	25 to 100 mm (1 to 4 in.)	JSB
<b>Butt Weld Joint (Stainless Steel F304):</b>		
JIS G3447 Piping Butt Weld Joint	15 to 125 mm (0.5 to 5 in.)	KJA
<b>Butt Weld Joint (Stainless Steel F316L):</b>		
JIS G3447 Piping Butt Weld Joint	15 to 125 mm (0.5 to 5 in.)	KJB
DIN 11850 Piping Butt Weld Joint	15 to 125 mm (0.5 to 5 in.)	KDB
ISO 2037 Piping Butt Weld Joint	15 to 125 mm (0.5 to 5 in.)	KKB

**Ceramics Tube:**

Process Connection	Size Range	Process Connection Code
<b>Wafer:</b>		
ASME Class 150	15 to 200 mm (0.5 to 8 in.) (32, 65, and 125 mm (1.25, 2.5, and 5 in.) are not available.)	AA1
ASME Class 300	15 to 200 mm (0.5 to 8 in.) (32, 65, and 125 mm (1.25, 2.5, and 5 in.) are not available.)	AA2
EN PN10	200 mm (8 in.)	AE1
EN PN16	80 to 200 mm (3 to 8 in.) (125 mm (5 in.) is not available.)	AE2
EN PN40	15 to 50 mm (0.5 to 2 in.) (32 mm (1.25 in.) is not available.)	AE4
JIS F12	80 to 200 mm (3 to 8 in.) (125 mm (5 in.) is not available.)	AG1
JIS 10K	15 to 200 mm (0.5 to 8 in.) (32, 65, and 125 mm (1.25, 2.5, and 5 in.) are not available.)	AJ1
JIS 20K	15 to 200 mm (0.5 to 8 in.) (32, 65, and 125 mm (1.25, 2.5, and 5 in.) are not available.)	AJ2
<b>Union Joint:</b>		
Screw Union Joint	2.5 to 5 mm (0.1 to 0.2 in.) (1/4 NPT), 10 mm (0.4 in.) (3/8 NPT)	GUN
	2.5 to 5 mm (0.1 to 0.2 in.) (R 1/4), 10 mm (0.4 in.) (R 3/8)	GUR
Welding Union Joint	2.5 to 10 mm (0.1 to 0.4 in.)	GUW

- Size Range by Electrode Material
  - Stainless Steel 316L  
2.5 to 500 mm, 0.1 to 20 in. (for PFA Lining)
  - Nickel Alloy  
2.5 to 500 mm, 0.1 to 20 in. (for PFA Lining)
  - Platinum-Iridium  
2.5 to 400 mm, 0.1 to 16 in. (for PFA Lining)
  - Tantalum  
2.5 to 400 mm, 0.1 to 16 in. (for PFA Lining)
  - Titanium  
2.5 to 400 mm, 0.1 to 16 in. (for PFA Lining)
  - Tungsten Carbide  
15 to 400 mm, 0.5 to 16 in. (for PFA Lining)
  - Platinum-Alumina Cermet  
2.5 to 200 mm, 0.1 to 8 in. (for Ceramics Tube)

- Size Range by Grounding Device
  - Grounding Ring:
    - Note: Grounding rings are not applicable to Ceramics Tube with sizes 2.5 to 10 mm (0.1 to 0.4 in.) for its structure. They are not applicable to Hygienic with sizes 15 to 125 mm (0.5 to 5 in.) for its structure as well.

**Grounding Ring Plate:**

- Stainless Steel 316L  
2.5 to 500 mm, 0.1 to 20 in. (for PFA Lining)  
15 to 200 mm, 0.5 to 8 in. (for Ceramics Tube)
- Nickel Alloy  
2.5 to 500 mm, 0.1 to 20 in. (for PFA Lining)  
15 to 200 mm, 0.5 to 8 in. (for Ceramics Tube)
- Titanium  
2.5 to 400 mm, 0.1 to 16 in. (for PFA Lining)  
15 to 200 mm, 0.5 to 8 in. (for Ceramics Tube)

**Grounding Ring Electrode:**

- Platinum-Iridium  
2.5 to 200 mm, 0.1 to 8 in. (for PFA Lining)  
15 to 200 mm, 0.5 to 8 in. (for Ceramics Tube)
- Tantalum  
2.5 to 200 mm, 0.1 to 8 in. (for PFA Lining)  
15 to 200 mm, 0.5 to 8 in. (for Ceramics Tube)

**Built-in Grounding Electrode:**

- Platinum-Iridium  
150 to 400 mm, 6 to 16 in. (for PFA Lining,  
Flange type)
- Tantalum  
150 to 400 mm, 6 to 16 in. (for PFA Lining,  
Flange type)

## ■ FUNCTIONS

Note: For AXFA11G remote transmitter, read general specifications (GS 01E20C01-01E).

### Display and Setting:

Parameter setting is possible through LCD with three infrared switches without opening the cover of the display.

Note: Parameter setting by setting tool such as HHT (handheld terminal) and FieldMate (device adjustment / management software) is also possible.

### Display:

Full dot matrix LCD, 64 × 128 dots, with backlight, dot reversal display available

### Display Language (\*):

Display Code 1:

English, French, German, Italian, Spanish, Portuguese, Russian and Japanese. The display languages are selectable and can be changed by customer.

Display Code 2:

English and Chinese. The display languages are selectable and can be changed by customer.

\*: The setting is English when shipped from factory.

### Display Screen Configuration:

Display Screen Item:

Status display (icon), Time (necessary to set the time at power-on), Data display (max. four lines), Infrared switch operation status

Flow Rate Screen:

Measured Data Screen or Online Trend Screen is available. Update period selectable from 0.2, 0.4, 1, 2, 4, and 8 seconds.

Measured Data Screen:

Display up to 4 data points simultaneously with numbers, bar graphs, icons, or character strings. Specify up to 8 points of data and change display data with infrared switches or automatic scroll function (scroll period 2, 4, or 8 seconds).

Selectable Data in Measured Data Screen:

Flow rate (%), Flow velocity, Volume flow rate, Mass flow rate, Calorie, Totalizer 1, Totalizer 2, Totalizer 3, Adhesion level, Current output 1, Current output 2, Flow noise level, Tag number, Communication protocol

Note: Calorie is available for Input / Output signal types H, J, and K, and Current output 2 for types B, C, and H.

Online Trend Screen:

Display one data as trend graph. The display data can be changed with infrared switches or automatic scroll function (scroll period 2, 4, or 8 seconds) selecting up to four data.

Selectable Data in Online Trend Screen:

Flow rate (%), Flow velocity, Volume flow rate, Mass flow rate, Calorie, Totalizer 1, Totalizer 2, Totalizer 3, Current output 1, Current output 2

Note: Calorie is available for Input / Output signal types H, J, and K, and Current output 2 for types B, C, and H.

Alarm Screen:

When an alarm occurs, the flow rate screen and the alarm screen are alternately displayed in the cycle (2, 4, or 8 seconds) linked with the flow rate screen update cycle. Select simple screen (single line display) or detail screen (with alarm countermeasure display).

NAMUR NE 107 Alarm Display Function:

Based on NAMUR NE 107, alarms are classified and displayed as follows. It can also be set to hide.

F: Failure

C: Function Check

S: Out of Specification

M: Maintenance Required

Offline Trend Screen (when microSD card (optional code MC) is selected):

Data stored by the data logging function can be displayed on the trend screen. The selectable data is the same as that for the Online Trend Screen.

Display Backlight Flashing (Squawk) Function:

Display backlight can be set to flash once or continuously at 4-second cycle to identify the device.

Display Operation Authority:

Display operation authority level against the parameters can be controlled by selecting from operator, maintenance, or specialist by passcode.

Operator:

Only parameters related to display setting can be set.

Maintenance:

Only parameters related to display setting and zero adjustment can be set.

Specialist:

All parameters can be set.

### Communication Function:

#### BRAIN Communication:

Communication Signal:

Superimposed on the Current Output 1

Communication Line Condition:

Load Resistance:

250 to 450Ω (including cable resistance)

Load Capacitance: 0.22 μF or less

Load Inductance: 3.3 mH or less

Input Impedance of Communicating Device:

10 kΩ or more (at 2.4 kHz)

Communication Distance:

Up to 1.5 km (0.93 miles), when polyethylene insulated PVC-sheathed cables (CEV cables) are used. Communication distance varies depending on the type of cable and wiring used.

Distance from Power Line:

15 cm (6 in.) or more. (Parallel wiring should be avoided)

#### HART Communication:

Protocol Version: HART 7

Communication Signal:

Superimposed on the Current Output 1

Communication Line Condition:

Load Resistance:

230 to 600Ω (including cable resistance)



**Input/Output Function:**

Input/Output Signal:

Input/Output up to four points can be selected from type A to K in the table.

**Input/Output**

Type	Input/Output Signal				Communication and I/O Code	
	I/O1 Terminal	I/O2 Terminal	I/O3 Terminal	I/O4 Terminal	BRAIN	HART 7
Type A	Current Output 1 (Active)	Pulse/Status Output 1 (Passive)	None	None	DA	JA
Type B			Pulse/Status Output 2 (Passive)	Current Output 2 (Active)	DB	JB
Type C			Status Input (No-voltage)	Current Output 2 (Active)	DC	JC
Type D			Status Output (Passive)	Pulse/Status Output 2 (Passive)	DD	JD
Type E			Status Input (No-voltage)	Pulse/Status Output 2 (Passive)	DE	JE
Type F			Status Input (No-voltage)	Pulse/Status Output 2 (Active, with internal resistor)	DF	JF
Type G			Status Input (No-voltage)	Pulse/Status Output 2 (Active, without internal resistor)	DG	JG
Type H			Current Output 2 (Passive)	Current Input (Active)	DH	JH
Type J			Pulse/Status Output 2 (Passive)	Current Input (Active)	DJ	JJ
Type K			Status Input (No-voltage)	Current Input (Active)	DK	JK

Note: "Active" means no external power supply, "Passive" means external power supply is required.

**Input Signal**• **Current Input (Active) (Type H, J, K)**

4 to 20 mA DC temperature signal from two-wire type transmitter.

Internal Power Supply: 24 V DC  $\pm 20\%$ , Current Range: 2.4 to 21.6 mA• **Status Input (Dry contact) (Type C, E, F, G, K)**Load Resistance: 200  $\Omega$  or less (ON), 100 k $\Omega$  or more (OFF)**Output Signal**• **Current Output (Active) (Type A to K)**

4 to 20 mA DC signal

Load Resistance: 750 $\Omega$  maximum, including cable resistance• **Current Output (Passive) (Type H)**

4 to 20 mA DC signal

External Power Supply: 10.5 to 32 V DC

Load Resistance: 911  $\Omega$  maximum, including cable resistance• **Pulse/Status Output (Passive) (Type A to K)**

Transistor contact output (open collector)

Contact Capacity: 30 V DC (OFF), 200 mA (ON)

Pulse Rate: 0.0001 to 10000 pps (pulse per second)

Pulse Width: 0.05, 0.1, 0.5, 1, 20, 33, 50, 100, 200, 330, 500, 1000, or 2000 ms configurable

Frequency Output Range: 1 to 12500 Hz

• **Pulse/Status Output (Active)****Without Internal Resistor (Type G)**

• Driving Electronic Counter

Load Resistance: 1 k $\Omega$  or more, Internal Power Supply: 24 V DC  $\pm 20\%$ 

Pulse Rate: 0.0001 to 10000 pps (pulse per second)

Pulse Width: 0.05, 0.1, 0.5, 1, 20, 33, 50, 100, 200, 330, 500, 1000, or 2000 ms configurable

Frequency Output Range: 1 to 12500 Hz

• Driving Electromechanical Counter

Maximum Current: 150 mA, Internal Power Supply: 24 VDC  $\pm 20\%$ 

Pulse Rate: 0.0001 to 2 pps (pulse per second)

Pulse Width: 20, 33, 50, or 100 ms configurable

**With Internal Resistor (Type F)**Internal resistor: 2.2 k $\Omega$ , Internal Power Supply: 24 VDC  $\pm 20\%$ 

Pulse Rate: 0.0001 to 10000 pps (pulse per second)

Pulse Width: 0.05, 0.1, 0.5, 1, 20, 33, 50, 100, 200, 330, 500, 1000, or 2000 ms configurable

**Temperature Input Processing Function:**

Input current signal as temperature difference or absolute temperature. It can be used for temperature monitor, mass flow calculation by density correction, and calorie calculation.

**Flow Calculation Function:**Excitation Method:

- Dual Frequency Excitation for sizes 2.5 to 400 mm (0.1 to 16 in.)
- Pulsed DC Excitation for size 500 mm (20 in.)

Span Setting:

Span flow can be set in units such as volume flow rate, mass flow rate, time, and flow rate value. The velocity unit can also be set.

Volume Flow Rate Unit:

kcf, cf, mcf, Mgal (US), kgal (US), gal (US), mgal (US), kbbbl (US)\*, bbl (US)\*, mbbbl (US)\*, μbbbl (US)\*, MI (megaliter), m<sup>3</sup>, kl (kiloliter), l (liter), cm<sup>3</sup>  
\*: "US Oil" or "US Beer" can be selected.

Mass Flow Rate Unit:

klb (US), lb (US), t (ton), kg, g

Calorie Unit:

MJ, kJ, J, kcal, cal, BTU (Specific heat setting and temperature input required)

Velocity Unit: ft, m (meter)Time Unit: s (sec), min, h (hour), d (day)Mass Flow Rate Processing:

The mass flow rate  $V_m$  is obtained in the following expression.

$$V_m = V_f \times \rho$$

$V_m$ : Mass flow rate [kg/s]

$V_f$ : Volume flow rate [m<sup>3</sup>/s]

$\rho$ : Density [kg/m<sup>3</sup>]

Calorie Processing:

The calorie  $Q$  is obtained in the following expression.

$$Q = c \times V_m \times \Delta T$$

$Q$ : Calorie [J/s]

$c$ : Specific heat [J/kg·K]

$V_m$ : Mass flow rate [kg/s]

$\Delta T$ : Temperature difference [K]

Damping Function (63% response):

Can be set for each measurement value of flow velocity, volume flow rate, mass flow rate, calorie, flow noise.

Output Damping:

For each measured value, the time constant for instantaneous value output and the time constant for totalization / pulse output can be individually set. Time constant 0.1 to 200.0 seconds (shipped with 3.0 seconds). In the case of piston pump etc., it is possible to measure pulsatile flow up to 1 Hz with output damping 0.1 sec. However, note that decreasing damping time generally increases output fluctuation.

Display Damping:

A common time constant can be set for each screen display value of each measurement value. Time constant 0.0 to 200.0 seconds (shipped with 0.0 seconds).

Current Output:

Current signal (4 to 20 mA DC) proportional to instantaneous flow rate is outputted.

Pulse Output:

The totalized value of the flow rate is converted into the number of pulses converted by the pulse rate, and is outputted.

Frequency Output:

Frequency signal (Duty 50%) proportional to the instantaneous value of the flow rate is outputted. Output terminal is shared with pulse output.

Totalization Function:

Three independent totalizers can be allocated independently, including the start and stop of integration, for each measured value of volume flow rate, mass flow rate, and calorie.

Totalization Type:

Forward / reverse difference flow totalization, Absolute value totalization, Forward direction totalization, Reverse direction totalization

Totalization Display:

Select from actual flow rate display or count value display scaled by counter conversion rate.

Low-cut Function:

Cut below the set actual flow rate value for each flow rate of current output, pulse output, and frequency output (\*). It is independent for current output, common for pulse output and frequency output. Low-cut function is not applied for display of process value on display.

\*: When "Forward and Reverse Flow Measurement" or "Absolute Range" is used, cut below the set actual flow rate value against the absolute value of the measured value.

**Output Processing Function:**Multi-range:

Flow range can be switched to two ranges by status input or automatic switching. By status output, it is possible to identify in what range the measurement is being measured, and the status is also displayed on the display.

Forward and Reverse Flow Measurement:

Flow rate measurement in both forward and reverse directions is possible. By status output, it is possible to identify in which direction the measurement is being performed, and the status is also displayed on the display.

Absolute Range:

With 12 mA as flow rate zero, measurements in the forward (12 to 20 mA) and reverse (4 to 12 mA) directions are possible in a single range.

Totalization Switch:

Status signal is outputted when the totalized value becomes equal to or larger than the set value.

Preset Totalization:

By parameter setting or status input, the totalized value is preset to zero or a set value.

0% Signal Lock:

With status input, the current output is forcibly fixed to 0%. Instantaneous flow rate display, pulse output, and flow rate totalization continue.

**Alarm Function:**Alarm Configuration:

Alarms are classified into system alarm (device failure), process alarm, setting alarm, and warning. Alarm output availability can be selected for each item.

Current Output at Alarm Occurrence:

The current output at alarm occurrence is arbitrarily selected from 2.4 mA or less, 3.8 mA fixed, 4 mA fixed, 20.5 mA fixed, 21.6 mA or more, measured value, or HOLD.

Alarm Countermeasure Indication:

A specific countermeasure method can be displayed on the display when an alarm occurs.

Alarm Type:

System Alarm:

CPU failure, A/D converter failure, Sensor coil circuit break (open), Sensor coil short circuit

Process Alarm:

Input signal error (signal overflow), Sensor empty pipe, Electrode adhesion (of insulator)

Setting Alarm:

Detect inconsistency in parameter setting

Warning:

Warning in a state where measurement can be continued

Alarm History: Keep history of up to four alarms.

**Verification Function:**

Function to diagnose the soundness of the device itself. Diagnose the magnetic circuit, excitation circuit, arithmetic processing circuit, etc. offline (i.e. flow measurement function stopped) and display the result without demounting the device from piping.

**Data Management Function:**

Store / Restore Function of Parameters:

Main parameters can be stored and restored using nonvolatile memory of display unit or optional microSD card. The restore can also be used for copying parameters to another device (except for parameters under unmatched specification for the devices).

Data Logging Function (when microSD card (optional code MC) is selected):

It is possible to log up to four process data at the same time. In addition to displaying the logged results on the trend screen, it is also possible to connect the microSD card to a PC and retrieve the data.

Logging Cycle:

1 second, 10 seconds, 30 seconds, 1 minute, 5 minutes, 30 minutes, 1 hour

Logging Time:

10 minutes, 30 minutes, 1 hour, 3 hours, 12 hours, 24 hours, 72 hours, 240 hours

Logging Data:

Flow velocity, Volume flow rate, Mass flow rate, Calorie, Flow noise, Adhesion level, Electrode potential (A, B), Flow signal peak value

Data Security During Power Failure:

Protection of data, such as parameters and integrated values, by nonvolatile memory at power failure.

Factory Default Parameter Restore:

It is possible to restore the parameters to the values that were set at the time of factory shipment.

**Lightning Protection:**

Built-in lightning protector for excitation(\*), signal common(\*), input / output terminals, and power supply terminal.

Test Standard: IEC61000-4-5

Test Method:

Series mode 1 kV / Common mode 2 kV  
Surge waveform 8/20 μS

\*: Integral Flowmeter is excluded.

**■ CONFORMITY STANDARDS**

**Safety Requirements:**

Note: The size 500 mm (20 in.) is not applicable.

- EN61010-1
- EN61010-2-030
- CAN/CSA-C22.2 No.61010-1-12
- CAN/CSA-C22.2 No.61010-2-30-12
- CAN/CSA-C22.2 No.94.2-07
- UL 61010-1 (3rd Edition)
- UL 61010-2-030 (1st Edition)
- UL 50E
- IEC 60529
- Altitude at Installation Site:  
Max. 2000 m above sea level
- Installation Category (Overvoltage category): II
- Micro Pollution Degree: 2
- Macro Pollution Degree: 4
- Protection Degree: IP66/67, Type 4X (CSA)

**EMC:**

- EN61326-1 Class A, Table 2 (For use in industrial locations)
- EN61326-2-3
- EN61000-3-2 Class A
- EN61000-3-3

## ■ PERFORMANCE

### Accuracy:

- AXG Integral Flowmeter, or combination of AXG Remote Sensor and AXG4A Remote Transmitter

Size mm (in.)	Flow Velocity V m/s (ft/s)	Standard Accuracy (Accuracy Code B)
2.5 to 15 (0.1) (0.5)	$V < 0.3$ (1)	$\pm 1.0$ mm/s
	$0.3 \leq V \leq 10$ (1) (33)	$\pm 0.3$ % of rate
25 to 400 (1) (16)	$V < 0.15$ (0.5)	$\pm 0.5$ mm/s
	$0.15 \leq V \leq 10$ (0.5) (33)	$\pm 0.3$ % of rate

Size mm (in.)	Flow Velocity V m/s (ft/s)	High Grade Accuracy (Accuracy Code C)
25 to 200 (1) (8)	$V < 0.15$ (0.5)	$\pm 0.5$ mm/s
	$0.15 \leq V < 1$ (0.5) (3.3)	$\pm 0.18\%$ of rate $\pm 0.2$ mm/s
	$1 \leq V \leq 10$ (3.3) (33)	$\pm 0.15\%$ of rate

### Sizes 2.5 to 15 mm (0.1 to 0.5 in.) Standard Accuracy (Accuracy Code B)

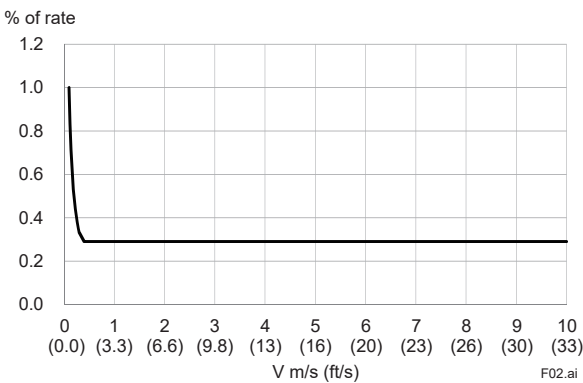

### Sizes 25 to 400 mm (1 to 16 in.) Standard Accuracy (Accuracy Code B)

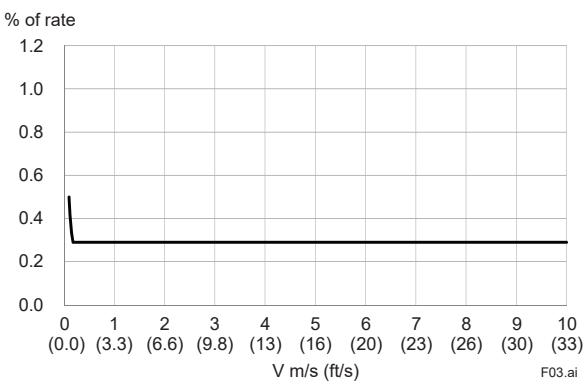

### Sizes 25 to 200 mm (1 to 8 in.) High Grade Accuracy (Accuracy Code C)

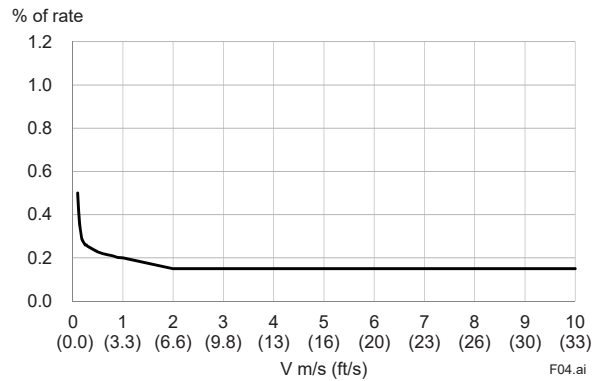

- Combination of AXG Remote Sensor and AXFA11 Remote Transmitter

Size mm (in.)	Flow Velocity V m/s (ft/s)	Standard Accuracy (Accuracy Code B)
2.5 to 15 (0.1) (0.5)	$V < 0.3$ (1)	$\pm 1.0$ mm/s
	$0.3 \leq V \leq 10$ (1) (33)	$\pm 0.35$ % of rate
25 to 400 (1) (16)	$V < 0.15$ (0.5)	$\pm 0.5$ mm/s
	$0.15 \leq V \leq 10$ (0.5) (33)	$\pm 0.35$ % of rate
500 (20)	$V < 0.3$ (1)	$\pm 2.0$ mm/s
	$0.3 \leq V \leq 10$ (1) (33)	$\pm 0.35\%$ of rate $\pm 1.0$ mm/s

Size mm (in.)	Flow Velocity V m/s (ft/s)	High Grade Accuracy (Accuracy Code C)
25 to 200 (1) (8)	$V < 0.15$ (0.5)	$\pm 0.5$ mm/s
	$0.15 \leq V < 1$ (0.5) (3.3)	$\pm 0.18\%$ of rate $\pm 0.2$ mm/s
	$1 \leq V \leq 10$ (3.3) (33)	$\pm 0.2\%$ of rate

### Sizes 2.5 to 15 mm (0.1 to 0.5 in.) with AXFA11 Standard Accuracy (Accuracy Code B)

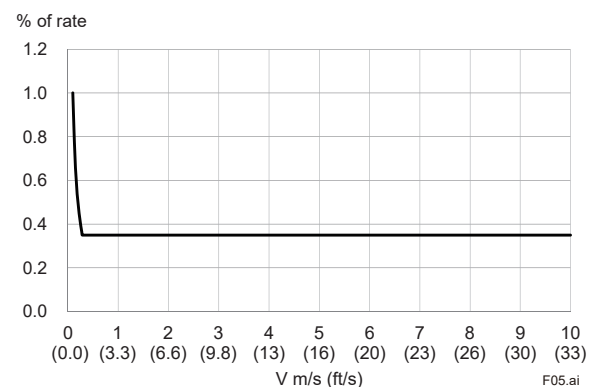

**Sizes 25 to 400 mm (1 to 16 in.)  
with AXFA11 Standard Accuracy (Accuracy Code B)**

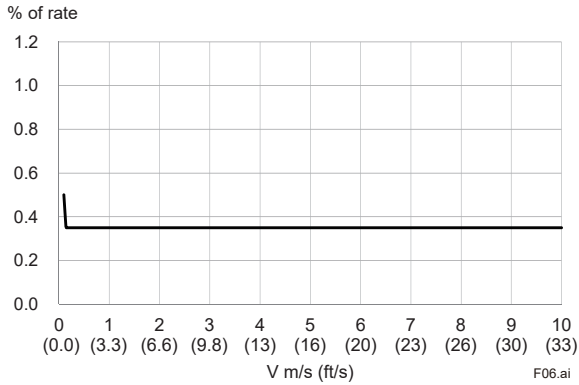

**Size 500 mm (20 in.)  
with AXFA11 Standard Accuracy (Accuracy Code B)**

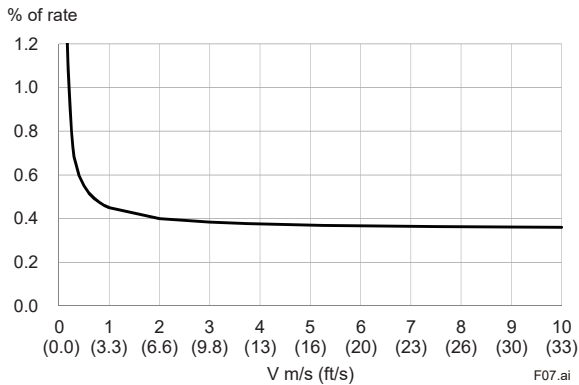

**Sizes 25 to 200 mm (1 to 8 in.)  
with AXFA11 High Grade Accuracy (Accuracy Code C)**

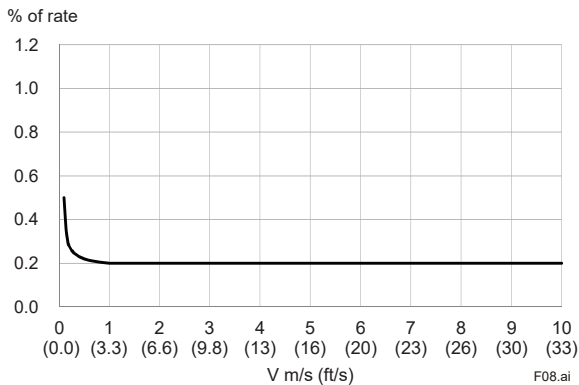

Note: The accuracy above is the result of calibration test at our water flow facility before shipment. It is defined by the integrated value of the pulse output. As for the current output accuracy, add  $\pm 8 \mu\text{A}$  ( $\pm 0.05\%$  of span) to the accuracy above.

Calibration takes place at reference conditions as below.

- Medium: Water
- Density: 0.9 to 1.1 kg/l
- Medium temperature: 10 to 35°C (50 to 95°F)  
(Average temperature 22.5°C (72.5°F))
- Ambient temperature: 10 to 35°C (50 to 95°F)
- Process pressure (absolute):  
0.1 to 0.2 MPa (15 to 29 psi)
- Reference Standards:  
JIS B 7554, ISO 4185, ISO 5168, ISO 20456,  
BS EN 29104

**Repeatability:**

- $\pm 0.1\%$  of rate (Velocity 1m/s (3.3 ft/s) or above)
- $\pm 0.05\%$  of rate  $\pm 0.5 \text{ mm/s}$  (Velocity below 1m/s (3.3 ft/s))

**Measurement Range:**

- Minimum Span Velocity: 0.1 m/s (0.33 ft/s)
- Maximum Span Velocity: 10 m/s (33 ft/s)

Note: For details of span flow rate, read "Sizing Data", and "Ordering Information".

**Power Consumption:**

- Integral Type: 13 W
- Remote Type: 13 W (with AXG4A Remote Transmitter)  
20 W (with AXFA11 Remote Transmitter)

Note: The power consumption is the same as above regardless of the communication and I/O type.

**Insulation Resistance:**

**Integral Flowmeter:**

- Between power supply terminals and ground terminal:  
100 MΩ/500 V DC
- Between power supply terminals and input/output terminals:  
100 MΩ/500 V DC
- Between ground terminal and input/output terminals:  
20 MΩ/100 V DC or 125 V DC
- Between input/output terminals:  
20 MΩ/100 V DC or 125 V DC

**Remote Sensor:**

- Between signal terminals:  
100 MΩ/500 V DC
- Between signal terminals and common terminal:  
100 MΩ/500 V DC
- Between excitation current terminal and signal / common terminals:  
100 MΩ/500 V DC

**Remote Transmitter:**

- Between power supply terminals and ground terminal:  
100 MΩ/500 V DC
- Between power supply terminals and input/output or excitation current terminals:  
100 MΩ/500 V DC
- Between ground terminal and input/output or excitation current terminals:  
20 MΩ/100 V DC or 125 V DC
- Between input/output and excitation current terminals:  
20 MΩ/100 V DC or 125 V DC

**Withstand Voltage:**

**Integral Flowmeter:**

- Between power supply terminals and ground terminal:  
1400 V AC for 2 seconds
- Between power supply terminals and input/output terminals:  
1400 V AC for 2 seconds

**Remote Sensor (Optional code WT1):**

- Between excitation current terminal and ground terminal:  
1000 V AC for 1 minute



**Remote Sensor (Optional code WT2):**

Between excitation current terminal and ground terminal:

1500 V AC for 1 minute

Between signal terminals and excitation current terminal:

1500 V AC for 1 minute

**Remote Transmitter:**

Between power supply terminals and ground terminal:

1400 V AC for 2 seconds

Between power supply terminals and input/output terminals:

1400 V AC for 2 seconds

Between excitation current terminal and ground terminal:

160 V AC for 2 seconds

Between excitation current terminal and input/output terminals:

350 V AC for 2 seconds

**■ NORMAL OPERATING CONDITIONS**

**Ambient Temperature:**

-40 to 60°C (-40 to 140°F)

Note: Minimum value is limited according to minimum fluid temperature of sensor's specification. Read "Fluid Temperature and Pressure".

Display operating range is -20 to 60°C (-4 to 140°F).

**Ambient Humidity:**

0 to 100%

Note: Lengthy continuous operation at 95% or more is not recommended.

**Power Supply:**

Power Supply Code 1:

AC Type:

Rated Power Supply: 100 to 240 V AC, 50/60 Hz

Operating Voltage Range: 80 to 264 V AC

DC Type:

Rated Power Supply: 100 to 120 V DC

Operating Voltage Range: 90 to 130 V DC

Power Supply Code 2:

AC Type:

Rated Power Supply: 24 V AC, 50/60 Hz

Operating Voltage Range: 20.4 to 28.8 V AC

DC Type:

Rated Power Supply: 24 V DC

Operating Voltage Range: 20.4 to 28.8 V DC

**Supply Voltage and Power Supply Cable Length for Power Supply Code 2:**

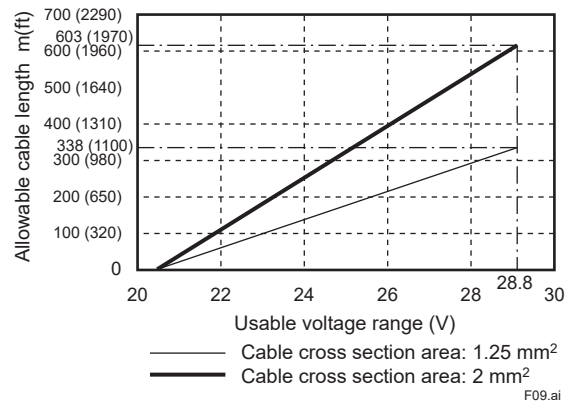

**Fluid Conductivity:**

Size 2.5 to 10 mm (0.1 to 0.4 in.): 5 µS/cm or larger

Size 15 to 125 mm (0.5 to 5 in.): 1 µS/cm or larger

Size 150 to 400 mm (6 to 16 in.): 3 µS/cm or larger

Size 500 mm (20 in.): 20 µS/cm or larger

Note: For measuring low conductivity fluids, read "Cautions on Selection and Installation".

**Signal Cable Length and Fluid Conductivity (Remote Sensor):**

**Sizes 2.5 to 10 mm (0.1 to 0.4 in.)**

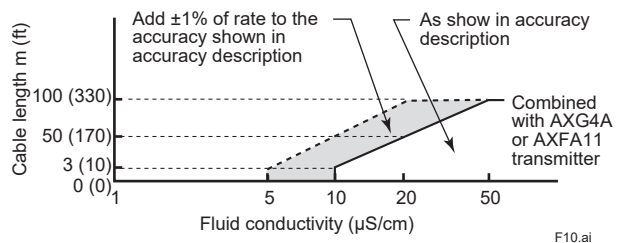

**Sizes 15 to 125 mm (0.5 to 5 in.)**

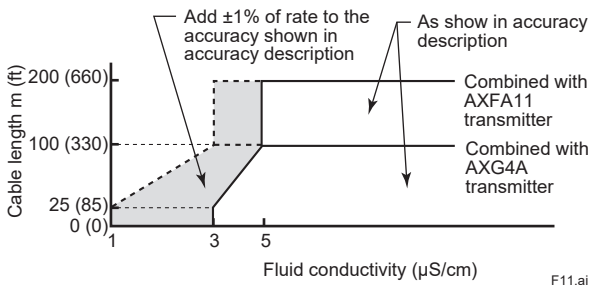

F11.ai

**Sizes 150 to 400 mm (6 to 16 in.)**

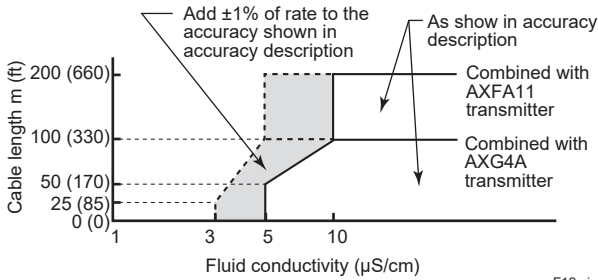

F12.ai

**Size 500 mm (20 in.)**

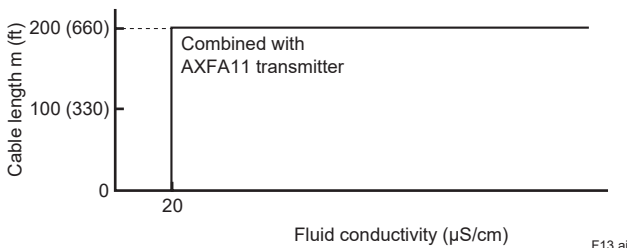

F13.ai

**Fluid Temperature and Pressure:**

The following figure shows the usable temperature and pressure range of the sensor in each specification. It is also limited by the flange pressure rating of the process connection.

**PFA Lining, Remote Sensor (excluding high pressure type (ASME Class 600 flange) and Hygienic)**

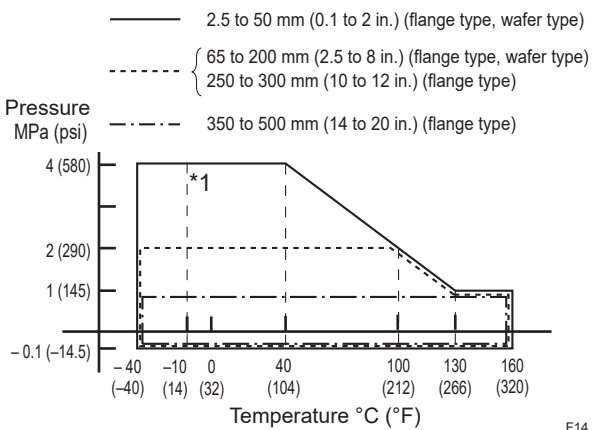

F14.ai

**PFA Lining, Integral Flowmeter (excluding high pressure type (ASME Class 600 flange), and Hygienic)**

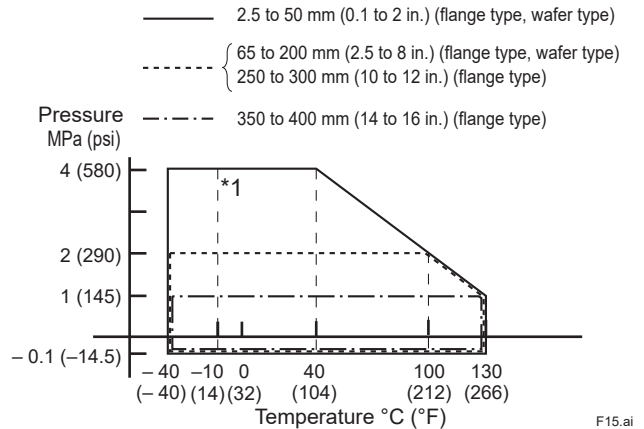

F15.ai

\*1: For wafer types of 150 to 200 mm (6 to 8 in.) or carbon steel flange types (process connection code: C□□) of 50 to 500 mm (2 to 20 in.), the minimum temperature is -10°C (14°F).

**PFA Lining, Remote Sensor and Integral Flowmeter (high pressure type (ASME Class 600 flange))**

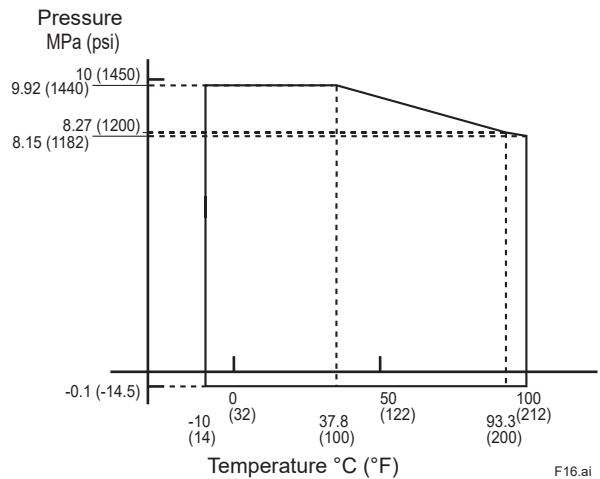

F16.ai

**PFA Lining, Remote Sensor and Integral Flowmeter (Hygienic)**

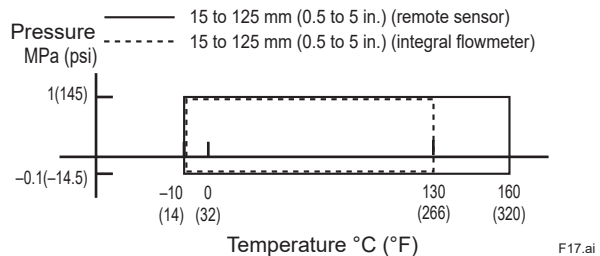

F17.ai

Note: For fluid temperature of 120°C (248°F) or more (Maximum: 160°C (320°F)), select optional code GH.

**Ceramics Tube, Remote Sensor**

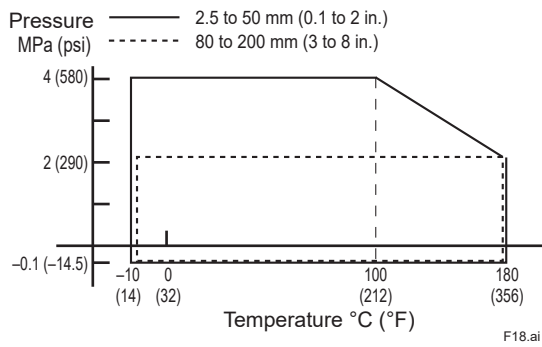

**Ceramics Tube, Integral Flowmeter**

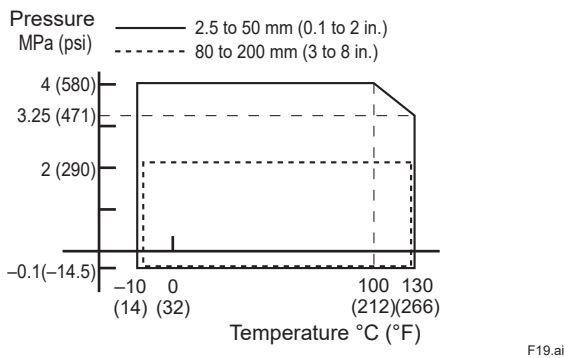

**Thermal Shock Temperature and Flow Velocity of Ceramics Tube:**

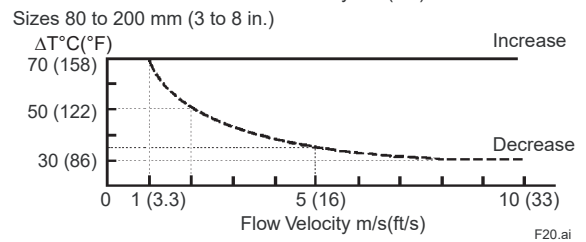
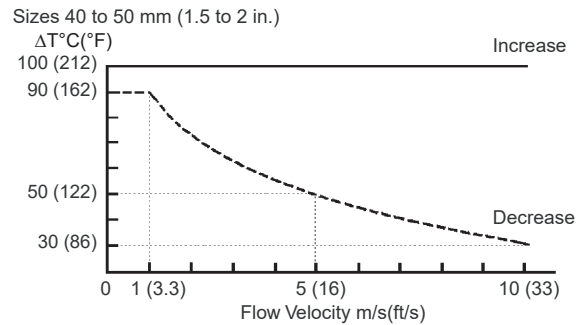
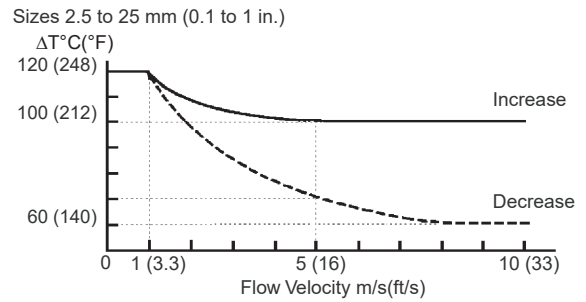

“Decrease” means that the temperature of a measured fluid drops rapidly, while “Increase” means that the temperature rises rapidly. The maximum allowable ranges in both cases are indicated by the curves shown in the diagrams, with the solid line indicating the maximum increase, and the broken line the maximum decrease.

$\Delta T$ : Change in temperature of measured fluid in one second

Flow velocity: Flow velocity of the measured fluid

**Allowable Conditions for Cleaning Lining (Hygienic):**

Steam or hot water cleaning:  
 Max. temp. 150°C (302°F), time period 60 minutes or less

**Vibration Conditions:**

Integral Flowmeter:  
 19.6 m/s<sup>2</sup> - rms (5 to 2000 Hz)

Remote Sensor:  
 34.3 m/s<sup>2</sup> - rms (5 to 2000 Hz)

Remote Transmitter:  
 19.6 m/s<sup>2</sup> - rms (5 to 2000 Hz)

Note: Vibration conditions are based on IEC 60068-2-64. Avoid installation in a place with much vibration (vibration frequency 2000 Hz or more). It may cause damage to the device.

## ■ CAUTIONS ON SELECTION AND INSTALLATION

### Combined Transmitter:

In the following cases, combine with AXFA11G remote transmitter. If it is considered that the flow noise in the fluid could be large because of low conductivity, or high concentration slurry, etc. and the size is 250 mm (10 in.) or more, it is recommended to combine with AXFA11G remote transmitter.

- When mounting remote transmitter to wall or panel
- When cable length exceeds 100 m
- When using 5 or more input/output terminals

### Lining:

#### PFA Lining:

It is excellent in chemical resistance. We adopt the material approved by FDA (US Food and Drug Administration).

#### Ceramics Tube:

It is excellent in chemical resistance, heat resistance and abrasion resistance. Measuring pipe sintered with high purity alumina ceramics is a structure that also serves as a lining.

### Grounding Device:

The grounding device can be selected as an optional specification. It is unnecessary to use it for metal piping which has no lining. In that case, connect the piping and the sensor flange part (mini-flange or one-piece casting structured measuring pipe for wafer type) with grounding wire supplied by customer (see the figure below). Be sure to select the grounding device when installed at plastic or lining piping.

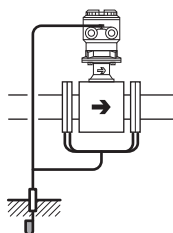

F21.ai

There are thin type (thickness 1 to 2 mm) and thick type (thickness 3 to 4 mm, or 8.5 to 10.5 mm for high pressure type) for grounding rings. If the flange is ASME Class 300, EN PN 40 etc. for high fluid pressure and the tightening torque is high, the thick type is recommended.

Grounding ring (electrode type) and built-in grounding electrode can not be used for permeable fluid (e.g. nitric acid, hydrofluoric acid, high temperature sodium hydroxide etc.).

The built-in grounding electrode (for sizes 150 to 400 mm, 6 to 16 in.) has fewer seals against fluid than the grounding ring, so leakage possibility will be less if the customer piping is plastic or lining one.

**Recommended Gasket (for customer piping flange):**

Use compressed non-asbestos joint sheet gaskets, PTFE-sheathed non-asbestos joint sheet gaskets or gaskets which have equivalent elasticity. When selecting optional code GA, GC, or GD for plastic piping, use rubber gaskets or ones which have equivalent elasticity (such as PTFE-sheathed rubber gaskets).

Dimensions of the gasket should be determined with reference to the following table (by process connection and lining) and figure. If the inner diameter of the gasket is too large or the outer diameter is too small, liquid leakage may occur.

Unit: mm

Size	PFA Lining									Ceramics Tube				
	Wafer				Flange					Wafer				
	Inner Diameter for Effective Sealing [øA]	Outer Diameter for Effective Sealing [øB]	Recommended Inner Diameter of Gasket		Minimum Inner Diameter of Gasket*2	Inner Diameter for Effective Sealing [øA]	Outer Diameter for Effective Sealing [øB]	Recommended Inner Diameter of Gasket		Minimum Inner Diameter of Gasket*2	Inner Diameter for Effective Sealing [øA]	Outer Diameter for Effective Sealing [øB]	Recommended Inner Diameter of Gasket	
		Flat Gasket [øC]	PTFE-sheathed Gasket [øD]				Flat Gasket [øC]	PTFE-sheathed Gasket [øD]				Flat Gasket [øC]	PTFE-sheathed Gasket [øD]	
2.5	15	38	17	22	15	15	30	17 [15]*1	22 [19]*1	15	—	—	—	—
5	15	38	17	22	15	15	30	17 [15]*1	22 [19]*1	15	—	—	—	—
10	15	38	17	22	15	15	30	17 [15]*1	22 [19]*1	15	—	—	—	—
15	18	38	—	22	15	22	34	—	22	15	15	33	22	15
25	32	54	—	35	28	35	54	—	35	29	27	50	35	27
32	37	58	—	43	34	40	64	—	43	34	—	—	—	—
40	45	71	—	49	41	48	72	—	49	41	40	68	49	40
50	58	84	—	61	53	61	89	—	61	53	52	82	61	52
65	69	103	—	84	66	72	108	—	84	66	—	—	—	—
80	81	114	—	90	81	85	119	—	90	81	81	112	90	81
100	106	140	—	115	102	110	146	—	115	102	98	134	115	98
125	131	165	—	141	128	136	173	—	141	128	—	—	—	—
150	164	190	—	167	147	164	209 [216]*1	—	167	150	144	188	167	144
200	218	240	—	218	199	218	259 [272]*1	—	218	201	192	240	218	192
250	—	—	—	—	—	270	320 [332]*1	—	270	250	—	—	—	—
300	—	—	—	—	—	321	367 [392]*1	—	321	301	—	—	—	—
350	—	—	—	—	—	350	412	—	359	330	—	—	—	—
400	—	—	—	—	—	401	475	—	410	381	—	—	—	—
500	—	—	—	—	—	581	581 <606>*1	—	513	465	—	—	—	—

Unit: inch

Size	PFA Lining									Ceramics Tube				
	Wafer				Flange					Wafer				
	Inner Diameter for Effective Sealing [øA]	Outer Diameter for Effective Sealing [øB]	Recommended Inner Diameter of Gasket		Minimum Inner Diameter of Gasket*2	Inner Diameter for Effective Sealing [øA]	Outer Diameter for Effective Sealing [øB]	Recommended Inner Diameter of Gasket		Minimum Inner Diameter of Gasket*2	Inner Diameter for Effective Sealing [øA]	Outer Diameter for Effective Sealing [øB]	Recommended Inner Diameter of Gasket	
		Flat Gasket [øC]	PTFE-sheathed Gasket [øD]				Flat Gasket [øC]	PTFE-sheathed Gasket [øD]				Flat Gasket [øC]	PTFE-sheathed Gasket [øD]	
0.1	0.59	1.50	0.67	0.87	0.59	0.59	1.18	0.67 [0.59]*1	0.87 [0.75]*1	0.59	—	—	—	—
0.2	0.59	1.50	0.67	0.87	0.59	0.59	1.18	0.67 [0.59]*1	0.87 [0.75]*1	0.59	—	—	—	—
0.4	0.59	1.50	0.67	0.87	0.59	0.59	1.18	0.67 [0.59]*1	0.87 [0.75]*1	0.59	—	—	—	—
0.5	0.71	1.50	—	0.87	0.59	0.87	1.34	—	0.87	0.59	0.59	1.30	0.87	0.59
1.0	1.26	2.13	—	1.38	1.10	1.39	2.13	—	1.38	1.14	1.06	1.97	1.38	1.06
1.25	1.46	2.28	—	1.69	1.34	1.59	2.53	—	1.69	1.34	—	—	—	—
1.5	1.76	2.80	—	1.93	1.61	1.89	2.83	—	1.93	1.61	1.57	2.68	1.93	1.57
2.0	2.26	3.31	—	2.40	2.09	2.39	3.50	—	2.40	2.09	2.05	3.23	2.40	2.05
2.5	2.73	4.06	—	3.31	2.60	2.84	4.25	—	3.31	2.60	—	—	—	—
3.0	3.19	4.49	—	3.54	3.19	3.33	4.69	—	3.54	3.19	3.19	4.41	3.54	3.19
4.0	4.19	5.51	—	4.53	4.02	4.34	5.75	—	4.53	4.02	3.86	5.28	4.53	3.86
5.0	5.14	6.50	—	5.55	5.04	5.34	6.81	—	5.55	5.04	—	—	—	—
6.0	6.46	7.48	—	6.57	5.79	6.46	8.23 [8.50]*1	—	6.57	5.91	5.67	7.40	6.57	5.67
8.0	8.58	9.45	—	8.58	7.83	8.58	10.20 [10.71]*1	—	8.58	7.91	7.56	9.45	8.58	7.56
10	—	—	—	—	—	10.61	12.60 [13.07]*1	—	10.63	9.84	—	—	—	—
12	—	—	—	—	—	12.64	14.44 [15.43]*1	—	12.64	11.85	—	—	—	—
14	—	—	—	—	—	13.76	16.22	—	14.13	12.99	—	—	—	—
16	—	—	—	—	—	15.78	18.70	—	16.14	15.00	—	—	—	—
20	—	—	—	—	—	22.87	22.87 <23.86>*1	—	20.20	18.31	—	—	—	—

\*1: The value varies depending on the selection of process connection code:  
 DJ1, DJ2, DE4: Values in [ ].  
 BA2, BJ2, CA2, CJ2, PA2: Values in { }.  
 BE2, CE2: Values in < > .

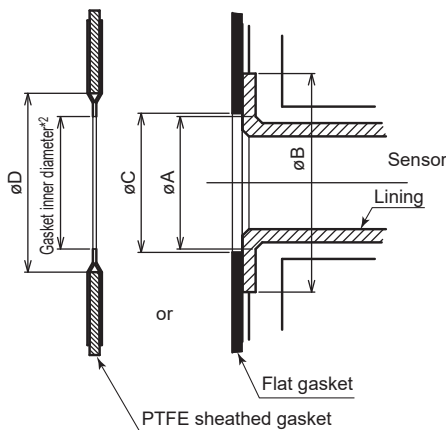

\*2: To prevent the gasket from protruding into the flow path, make sure that this length is smaller than the minimum inner diameter of the gasket in the table.



For high pressure type (ASME Class 600 flange), use a flat gasket that matches the outer diameter and inner diameter of the grounding ring considering the dimensions of the seal structure of the flange. Do not use a spiral wound gasket. Also, be careful not to damage the flange surface of the sensor by excessive tightening. The structural figure of grounding ring with flange and the dimensions of inner and outer diameter of the grounding ring are shown below. Note that the grounding ring must be selected for high pressure type.

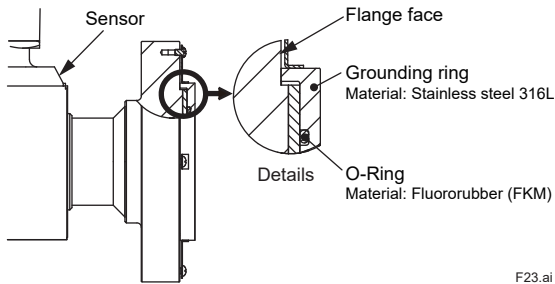

F23.ai

**Grounding Rings for High Pressure Type**

Unit: mm (approx. in.)

Size	Outer Diameter	Inner Diameter
25 (1)	69 (2.72)	29.0 (1.14)
40 (1.5)	92 (3.62)	35.4 (1.39)
50 (2)	108 (4.25)	46.5 (1.83)
80 (3)	147 (5.79)	70.9 (2.79)
100 (4)	185 (7.28)	93.0 (3.66)

**Noise Avoidance:**

The flowmeter should be installed away from electrical motors, transformers, and other power sources in order to avoid interference with measurement. When using multiple magnetic flowmeters, install the flowmeters setting the distance from each other by at least five times of the diameter of the larger one.

**Mounting of Flowmeters and Required Lengths of Straight Runs:**

Based on JIS B 7554 “Electromagnetic Flowmeters” and our piping condition test data, we recommend the piping conditions as shown in the following figures. This is not always enough when the piping line incorporates multiple conditions at the same time.

D: Sensor Size

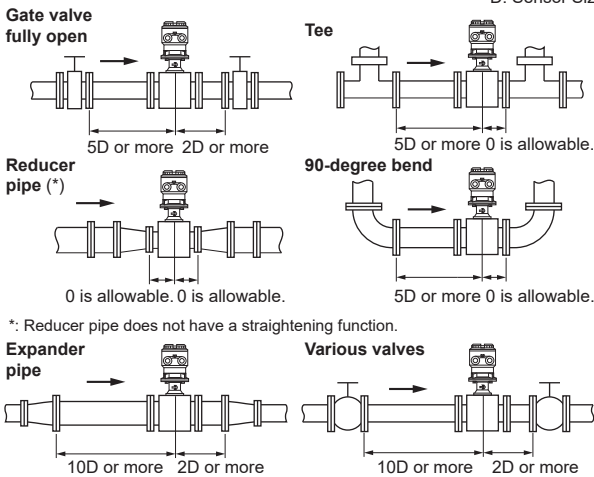

F24.ai

**Required straight runs**

- Do not install anything in the vicinity that may interfere with the magnetic field, induced signal voltages, or flow velocity distributions of the flowmeter.
- A straight run may not be required on the downstream side of the flowmeter. However, if a downstream valve or other fitting causes irregularity or deviation in flows, provide a distance of 2D to 3D on the downstream side.
- The valves shall be mounted on the downstream side so that deviated flows do not occur in the sensor and to avoid startup from an empty condition.
- In case the piping conditions are compounded, install on the straight pipe section where the upstream part is sufficiently rectified.

**Maintaining Stable Fluid Conductivity:**

Do not install the flowmeter where fluid conductivity tends to become uneven. If chemicals are fed near the upstream side of a magnetic flowmeter, they may affect the flow-rate's indications. To avoid this situation, it is recommended that the chemical feed ports be located on the downstream side of the flowmeter. If it is unavoidable that chemicals must be fed on the upstream side, provide a sufficient length of straight run (approximately 50D or more) to ensure the proper mixture of fluids.

**Low Conductivity Fluid:**

When used for fluids with high flow noise (pure water, low viscosity and low conductivity fluid such as alcohols), the output fluctuation increases and the measurement is affected. In that case, using the capacitance magnetic flowmeter ADMAG CA, vortex flowmeter, or coriolis flowmeter is recommended.

**Permeable Fluid:**

For use with permeable fluid (e.g. nitric acid, hydrofluoric acid, high-temperature sodium hydroxide, etc.), selecting a model with PFA lining, vent hole (optional code H), and grounding ring plate (thick type)(optional code GRN, GRJ, or GRW), or the capacitance magnetic flowmeter ADMAG CA is recommended. Those help reduce the adhesion on the inner surface of the pipe.

**Adhesive Fluid of Insulator:**

When measuring adhesive fluid of insulator, selecting mirror finished PFA lining or ceramics tube (optional code PM or CM), or the capacitance magnetic flowmeter ADMAG CA is recommended.

**Abrasive Slurry Fluid:**

For abrasive slurry fluids mixed with minerals, earth and sand etc., install on vertical piping. This reduces uneven wear of the lining. For sizes 200 mm (8 in.) or less, the AXG magnetic flowmeter with ceramics tube, the capacitance magnetic flowmeter ADMAG CA, or the AXW magnetic flowmeter with natural soft rubber lining is recommended.

**Mounting Positions:**

- Pipes must be fully filled with liquids. It is essential that pipes remain fully filled at all times, otherwise flow rate indications may be affected and measurement errors may be caused. Piping shall be designed so as to maintain the sensor filled with fluids. Vertical mounting is effective in such cases as when fluids tend to separate or solid matter may be precipitated. When employing vertical mounting, direct the fluids from the bottom to the top to ensure that the pipes remain fully filled.

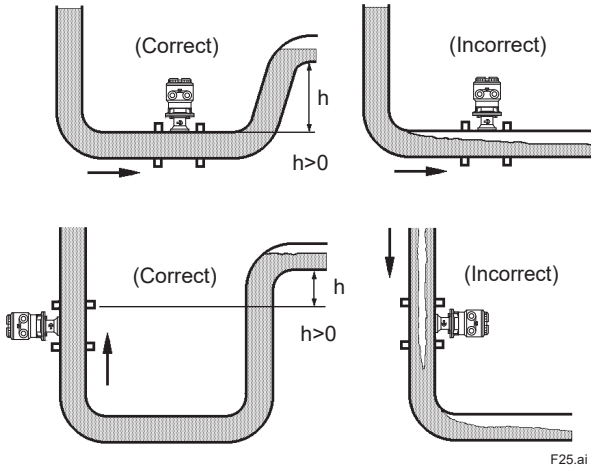

**Mounting Positions**

- Avoiding Air Bubbles. If air bubbles enter a measurement pipe, flow rate indications may be affected and measurement errors may be caused. In cases where fluids contain air bubbles, piping must be designed to prevent them from accumulating in the measurement pipe of a sensor. If a valve exists near the sensor, try to mount the sensor on the valve's upstream side in order to prevent a possible reduction of pressure inside the pipe, thereby avoiding the possibility of air bubbles.

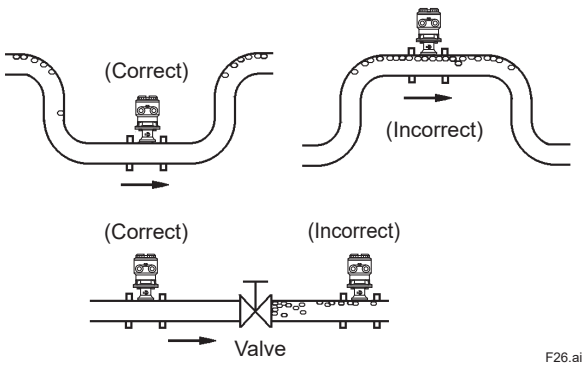

**Avoiding Air Bubbles**

**Mounting Orientation:**

If electrodes are perpendicular to the ground, air bubbles near the top or precipitates at the bottom may cause measurement errors. Ensure that the terminal box of a remote sensor and transmitter of an integral flowmeter are mounted above the piping to prevent water from entering them.

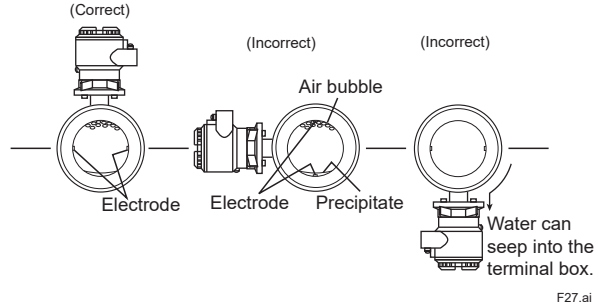

**Mounting Orientation**

■ MODEL AND SUFFIX CODE

<b>MODEL AND SUFFIX CODE</b>	
General-purpose, Wafer, PFA Lining	P.22
General-purpose, Flange, PFA Lining (Sizes 2.5 to 400 mm/0.1 to 16 in.)	P.24
General-purpose, Flange, PFA Lining (Size 500 mm/20 in.)	P.26
General-purpose, Flange, PFA Lining (High Pressure Type, ASME Class 600)	P.27
General-purpose, Ceramics Tube	P.28
Submersible, Wafer, PFA Lining	P.29
Submersible, Flange, PFA Lining (Sizes 15 to 400 mm/0.5 to 16 in.)	P.30
Submersible, Flange, PFA Lining (Size 500 mm/20 in.)	P.31
Submersible, Flange, PFA Lining (High Pressure Type, ASME Class 600)	P.32
Hygienic, PFA Lining	P.33
General-purpose, Remote Transmitter	P.34
Signal Cable	P.34
<b>OPTIONAL CODE</b>	
Application, Usage, and Operating Function	P.36
Tag Plate and Mounting Bracket	P.37
Piping Parts	P.38
Grounding Device	P.39
Gasket	P.40
Direction of Cable Entry, Waterproof and Plastic Glands	P.41
Certificate, Calibration, and Various Test	P.42

**Note:**

- 1: There are some limitations on the combination of specifications. Read specification code table and "Limitations on Specification Selection" when selecting specification code.
- 2: For both wafer and flange type of 2.5 to 10 mm (0.1 to 0.4 in.), prepare 15 mm (0.5 in.) diameter nominal flanges on the process pipe side. However, for the flanges EN PN40, JIS 10K, JIS 20K, types for the nominal diameter 10 mm (0.4 in.) flange can also be selected (Process Connection Code DE4, DJ1, and DJ2). The process connection of ceramics tube sizes 2.5 to 10 mm (0.1 to 0.4 in.) is only Union Joint (Screw and Welding type).
- 3: For EN standard wafer and flange type of sizes 2.5 to 50 mm (0.1 to 2 in.), select PN40 even for lower pressure rating because the dimensions of mating faces for PN10, 16, and 40 are the same. For EN standard wafer and flange type of sizes 65 to 150 mm (2.5 to 6 in.), select PN16 even for lower pressure rating because the dimensions of mating faces for PN10 and 16 are the same.
- 4: The dimensions of mating faces are based on the following flange standards. The usable range is also limited by fluid temperature and pressure conditions.  
JIS F12: JIS G 3443-2, JIS 10K, 20K: JIS B 2220 and JIS G 3443-2,  
ASME: ASME B 16.5, EN: EN 1092-1, JPI: JPI-7S-15, AS: AS2129
- 5: The grounding device is selectable from none, grounding ring, or built-in grounding electrode. When selecting the grounding ring or the built-in grounding electrode, it is also necessary to select its type (material etc.) from the optional codes.
- 6: The lay length (face to face) of the flange type of PFA lining sizes 15 to 400 mm (0.5 to 16 in.) conforms to ISO standard (ISO 20456) except for ASME Class 600 flange high pressure type. The lay length for ceramics tube (wafer and union joint) and Hygienic are the same as those of the conventional model ADMAG AXF series (AXF standard lay length). The lay length depends on the presence or absence of the optional grounding rings or gaskets, so see the Dimensional Drawings.
- 7: ⚠️ Lining, electrode, pipe connection adapter (for Hygienic), and grounding device (grounding ring plate, grounding ring electrode, built-in grounding electrode) are wetted parts. Users must consider the characteristics of selected wetted parts material and influence of process fluids. The use of inappropriate materials can result in the leakage of corrosive process fluids and cause injury to personnel and/or damage to plant facilities. It is also possible that the instrument itself can be damaged and that fragments from the instrument can contaminate the user's process fluids. Be very careful with highly corrosive process fluids such as hydrochloric acid, sulfuric acid, hydrogen sulfide, sodium hypochlorite, and high-temperature steam (150°C [302°F] or above). Contact Yokogawa for detailed information of the wetted parts material.
- 8: In the case of remote sensor, select "None (or Without)" for each specification code of "Power Supply", "Communication and I/O", "Transmitter Wiring Terminal" and "Display".

●General-purpose, Wafer, PFA Lining

Model	Suffix Code	Description	
AXG002		Magnetic Flowmeter (2.5 mm/0.1 in)	
AXG005		Magnetic Flowmeter (5 mm/0.2 in)	
AXG010		Magnetic Flowmeter (10 mm/0.4 in)	
AXG015		Magnetic Flowmeter (15 mm/0.5 in)	
AXG025		Magnetic Flowmeter (25 mm/1 in)	
AXG032		Magnetic Flowmeter (32 mm/1.25 in)	
AXG040		Magnetic Flowmeter (40 mm/1.5 in)	
AXG050		Magnetic Flowmeter (50 mm/2 in)	
AXG065		Magnetic Flowmeter (65 mm/2.5 in)	
AXG080		Magnetic Flowmeter (80 mm/3 in)	
AXG100		Magnetic Flowmeter (100 mm/4 in)	
AXG125		Magnetic Flowmeter (125 mm/5 in)	
AXG150		Magnetic Flowmeter (150 mm/6 in)	
AXG200		Magnetic Flowmeter (200 mm/8 in)	
Use	<b>-G</b>	General-purpose	
Construction	<b>A</b>	Integral Flowmeter	
	<b>D</b>	Remote Sensor (for AXFA11)	
	<b>G</b>	Remote Sensor (for AXG4A)	
Explosion Protection	<b>000</b>	Non Explosion Protection Approval	
Process Connection	Wafer	<b>AA1</b>	ASME Class 150 Wafer
		<b>AA2</b>	ASME Class 300 Wafer
		<b>AE1</b>	EN PN10 Wafer
		<b>AE2</b>	EN PN16 Wafer
		<b>AE4</b>	EN PN40 Wafer
		<b>AG1</b>	JIS F12 Wafer
		<b>AJ1</b>	JIS 10K Wafer
		<b>AJ2</b>	JIS 20K Wafer
	<b>AP1</b>	JPI Class 150 Wafer	
Lining	<b>A</b>	PFA Lining	
Electrode	<b>L</b>	Stainless Steel 316L	
	<b>P</b>	Platinum-Iridium	
	<b>H</b>	Nickel Alloy	
	<b>T</b>	Tantalum	
	<b>V</b>	Titanium	
	<b>W</b>	Tungsten Carbide	
Grounding Device	<b>1</b>	None	
	<b>2</b>	Grounding Rings (Select an optional code)	
Housing and Coating	<b>1</b>	Standard Material with Standard Coating	
	<b>2</b>	Standard Material with Rugged Coating	
Cable Entry	<b>0</b>	JIS G1/2 Female	
	<b>2</b>	ASME 1/2 NPT Female	
	<b>4</b>	ISO M20 x 1.5 Female	
Accuracy	<b>B</b>	Standard	
	<b>C</b>	High Grade (25 to 200 mm/1 to 8 in.)	
Power Supply	<b>-1</b>	100-240 V AC / 100-120 V DC	
	<b>-2</b>	24 V AC / DC	
	<b>-N</b>	None (Remote Sensor)	
Communication and I/O	<b>D</b> □	□: A, B, C, D, E, F, G, H, J, K BRAIN and I/O (Type A to K, See separate table)	
	<b>J</b> □	□: A, B, C, D, E, F, G, H, J, K HART 7 and I/O (Type A to K, See separate table)	
	<b>NN</b>	None (Remote Sensor)	
Transmitter Wiring Terminal	<b>1</b>	M4 Screw-type	
	<b>2</b>	Clamp Type	
	<b>N</b>	None (Remote Sensor)	

(Continued)

Display	<b>1</b>	With Display (English, Multi-language)
	<b>2</b>	With Display (English, Chinese)
	<b>N</b>	Without Display/Remote Sensor
Optional Specification	/ <input type="checkbox"/> Refer to optional specification table.	



●General-purpose, Flange, PFA Lining (2.5 to 400 mm/0.1 to 16 in.)

Model	Suffix Code	Description	
AXG002		Magnetic Flowmeter (2.5 mm/0.1 in)	
AXG005		Magnetic Flowmeter (5 mm/0.2 in)	
AXG010		Magnetic Flowmeter (10 mm/0.4 in)	
AXG015		Magnetic Flowmeter (15 mm/0.5 in)	
AXG025		Magnetic Flowmeter (25 mm/1 in)	
AXG032		Magnetic Flowmeter (32 mm/1.25 in)	
AXG040		Magnetic Flowmeter (40 mm/1.5 in)	
AXG050		Magnetic Flowmeter (50 mm/2 in)	
AXG065		Magnetic Flowmeter (65 mm/2.5 in)	
AXG080		Magnetic Flowmeter (80 mm/3 in)	
AXG100		Magnetic Flowmeter (100 mm/4 in)	
AXG125		Magnetic Flowmeter (125 mm/5 in)	
AXG150		Magnetic Flowmeter (150 mm/6 in)	
AXG200		Magnetic Flowmeter (200 mm/8 in)	
AXG250		Magnetic Flowmeter (250 mm/10 in)	
AXG300		Magnetic Flowmeter (300 mm/12 in)	
AXG350		Magnetic Flowmeter (350 mm/14 in)	
AXG400		Magnetic Flowmeter (400 mm/16 in)	
Use	<b>-G</b>	General-purpose	
Construction	<b>A</b>	Integral Flowmeter	
	<b>D</b>	Remote Sensor (for AXFA11)	
	<b>G</b>	Remote Sensor (for AXG4A)	
Explosion Protection	<b>000</b>	Non Explosion Protection Approval	
Process Connection	Stainless Steel Flange (F304)	<b>BA1</b>	ASME Class 150 Flange
		<b>BA2</b>	ASME Class 300 Flange
		<b>BE1</b>	EN PN10 Flange
		<b>BE2</b>	EN PN16 Flange
		<b>BE4</b>	EN PN40 Flange
		<b>BG1</b>	JIS F12 Flange
		<b>BJ1</b>	JIS 10K Flange
		<b>BJ2</b>	JIS 20K Flange
		<b>BP1</b>	JPI Class 150 Flange
		<b>DE4</b>	EN PN40 Flange (Nominal Diameter 10 mm)
		<b>DJ1</b>	JIS 10K Flange (Nominal Diameter 10 mm)
		<b>DJ2</b>	JIS 20K Flange (Nominal Diameter 10 mm)
	Stainless Steel Flange (F316)	<b>PA1</b>	ASME Class 150 Flange
		<b>PA2</b>	ASME Class 300 Flange
		<b>PE1</b>	EN PN10 Flange
		<b>PE2</b>	EN PN16 Flange
		<b>PE4</b>	EN PN40 Flange
	Carbon Steel Flange	<b>PJ1</b>	JIS 10K Flange
		<b>CA1</b>	ASME Class 150 Flange
		<b>CA2</b>	ASME Class 300 Flange
		<b>CE1</b>	EN PN10 Flange
		<b>CE2</b>	EN PN16 Flange
		<b>CE4</b>	EN PN40 Flange
		<b>CG1</b>	JIS F12 Flange
<b>CJ1</b>		JIS 10K Flange	
<b>CJ2</b>		JIS 20K Flange	
<b>CS1</b>		AS Table D Flange	
<b>CS2</b>		AS Table E Flange	
Lining		<b>A</b>	PFA Lining

(Continued)

Electrode	<b>L</b>	Stainless Steel 316L
	<b>P</b>	Platinum-Iridium
	<b>H</b>	Nickel Alloy
	<b>T</b>	Tantalum
	<b>V</b>	Titanium
	<b>W</b>	Tungsten Carbide
Grounding Device	<b>1</b>	None
	<b>2</b>	Grounding Rings (Select an optional code)
	<b>3</b>	Built-in Grounding Electrodes (Select an optional code)
Housing and Coating	<b>1</b>	Standard Material with Standard Coating
	<b>2</b>	Standard Material with Rugged Coating
Cable Entry	<b>0</b>	JIS G1/2 Female
	<b>2</b>	ASME 1/2 NPT Female
	<b>4</b>	ISO M20 x 1.5 Female
Accuracy	<b>B</b>	Standard
	<b>C</b>	High Grade (25 to 200 mm/1 to 8 in.)
Power Supply	<b>-1</b>	100-240 V AC / 100-120 V DC
	<b>-2</b>	24 V AC / DC
	<b>-N</b>	None (Remote Sensor)
Communication and I/O	<b>D</b> <input type="checkbox"/>	<input type="checkbox"/> : A, B, C, D, E, F, G, H, J, K BRAIN and I/O (Type A to K, See separate table)
	<b>J</b> <input type="checkbox"/>	<input type="checkbox"/> : A, B, C, D, E, F, G, H, J, K HART 7 and I/O (Type A to K, See separate table)
	<b>NN</b>	None (Remote Sensor)
Transmitter Wiring Terminal	<b>1</b>	M4 Screw-type
	<b>2</b>	Clamp Type
	<b>N</b>	None (Remote Sensor)
Display	<b>1</b>	With Display (English, Multi-language)
	<b>2</b>	With Display (English, Chinese)
	<b>N</b>	Without Display/Remote Sensor
Optional Specification		<input type="checkbox"/> Refer to optional specification table.

●General-purpose, Flange, PFA Lining (500 mm/20 in.)

Model	Suffix Code		Description
<b>AXG500</b>			Magnetic Flowmeter (500 mm/20 in.)
Use	<b>-G</b>		General-purpose
Construction	<b>D</b>		Remote Sensor (for AXFA11)
Explosion Protection	<b>000</b>		Non Explosion Protection Approval
Process Connection	Stainless Steel Flange (F304)	<b>BA1</b>	ASME Class 150 Flange
		<b>BE1</b>	EN PN10 Flange
		<b>BE2</b>	EN PN16 Flange
	Carbon Steel Flange	<b>CA1</b>	ASME Class 150 Flange
		<b>CE1</b>	EN PN10 Flange
		<b>CE2</b>	EN PN16 Flange
Lining	<b>A</b>		PFA Lining
Electrode	<b>L</b>		Stainless Steel 316L
	<b>H</b>		Nickel Alloy
Grounding Device	<b>1</b>		None
	<b>2</b>		Grounding Rings (Select an optional code)
Housing and Coating	<b>1</b>		Standard Material with Standard Coating
	<b>2</b>		Standard Material with Rugged Coating
Cable Entry	<b>0</b>		JIS G1/2 Female
	<b>2</b>		ASME 1/2 NPT Female
	<b>4</b>		ISO M20 x 1.5 Female
Accuracy	<b>B</b>		Standard
Power Supply	<b>-N</b>		None (Remote Sensor)
Communication and I/O	<b>NN</b>		None (Remote Sensor)
Transmitter Wiring Terminal	<b>N</b>		None (Remote Sensor)
Display	<b>N</b>		Without Display/Remote Sensor
Optional Specification	/□ Refer to optional specification table.		

**•General-purpose, Flange, PFA Lining (High Pressure Type, ASME Class 600)**

Model	Suffix Code		Description
<b>AXG025</b>			Magnetic Flowmeter (25 mm/1 in)
<b>AXG040</b>			Magnetic Flowmeter (40 mm/1.5 in)
<b>AXG050</b>			Magnetic Flowmeter (50 mm/2 in)
<b>AXG080</b>			Magnetic Flowmeter (80 mm/3 in)
<b>AXG100</b>			Magnetic Flowmeter (100 mm/4 in)
Use	<b>-G</b>		General-purpose
Construction	<b>A</b>		Integral Flowmeter
	<b>D</b>		Remote Sensor (for AXFA11)
	<b>G</b>		Remote Sensor (for AXG4A)
Explosion Protection	<b>000</b>		Non Explosion Protection Approval
Process Connection	Stainless Steel Flange (F304)	<b>EA4</b>	ASME Class 600 Flange (High Pressure)
Lining	<b>A</b>		PFA Lining
Electrode	<b>L</b>		Stainless Steel 316L
Grounding Device	<b>2</b>		Grounding Rings (Select the optional code GRN)
Housing and Coating	<b>1</b>		Standard Material with Standard Coating
	<b>2</b>		Standard Material with Rugged Coating
Cable Entry	<b>0</b>		JIS G1/2 Female
	<b>2</b>		ASME 1/2 NPT Female
	<b>4</b>		ISO M20 x 1.5 Female
Accuracy	<b>B</b>		Standard
Power Supply	<b>-1</b>		100-240 V AC / 100-120 V DC
	<b>-2</b>		24 V AC / DC
	<b>-N</b>		None (Remote Sensor)
Communication and I/O	<b>D</b> <input type="checkbox"/>		<input type="checkbox"/> : A, B, C, D, E, F, G, H, J, K BRAIN and I/O (Type A to K, See separate table)
	<b>J</b> <input type="checkbox"/>		<input type="checkbox"/> : A, B, C, D, E, F, G, H, J, K HART 7 and I/O (Type A to K, See separate table)
	<b>NN</b>		None (Remote Sensor)
Transmitter Wiring Terminal	<b>1</b>		M4 Screw-type
	<b>2</b>		Clamp Type
	<b>N</b>		None (Remote Sensor)
Display	<b>1</b>		With Display (English, Multi-language)
	<b>2</b>		With Display (English, Chinese)
	<b>N</b>		Without Display/Remote Sensor
Optional Specification			<input type="checkbox"/> Refer to optional specification table.

●General-purpose, Ceramics Tube

Model	Suffix Code	Description	
AXG002		Magnetic Flowmeter (2.5 mm/0.1 in)	
AXG005		Magnetic Flowmeter (5 mm/0.2 in)	
AXG010		Magnetic Flowmeter (10 mm/0.4 in)	
AXG015		Magnetic Flowmeter (15 mm/0.5 in)	
AXG025		Magnetic Flowmeter (25 mm/1 in)	
AXG040		Magnetic Flowmeter (40 mm/1.5 in)	
AXG050		Magnetic Flowmeter (50 mm/2 in)	
AXG080		Magnetic Flowmeter (80 mm/3 in)	
AXG100		Magnetic Flowmeter (100 mm/4 in)	
AXG150		Magnetic Flowmeter (150 mm/6 in)	
AXG200		Magnetic Flowmeter (200 mm/8 in)	
Use	<b>-G</b>	General-purpose	
Construction	<b>A</b>	Integral Flowmeter	
	<b>D</b>	Remote Sensor (for AXFA11)	
	<b>G</b>	Remote Sensor (for AXG4A)	
Explosion Protection	<b>000</b>	Non Explosion Protection Approval	
Process Connection	Wafer	<b>AA1</b>	ASME Class 150 Wafer
		<b>AA2</b>	ASME Class 300 Wafer
		<b>AE1</b>	EN PN10 Wafer
		<b>AE2</b>	EN PN16 Wafer
		<b>AE4</b>	EN PN40 Wafer
		<b>AG1</b>	JIS F12 Wafer
		<b>AJ1</b>	JIS 10K Wafer
		<b>AJ2</b>	JIS 20K Wafer
	Union Joint	<b>GUN</b> (Stainless Steel 316L)	Screw Union Joint (2.5 to 5 mm (0.1 to 0.2 in.): 1/4 NPT, 10 mm (0.4 in.): 3/8 NPT)
		<b>GUR</b> (Stainless Steel 316L)	Screw Union Joint (2.5 to 5 mm (0.1 to 0.2 in.): R 1/4, 10 mm (0.4 in.): R 3/8)
<b>GUW</b> (Stainless Steel 316L)		Welding Union Joint (2.5 to 10 mm (0.1 to 0.4 in.))	
Lining	<b>C</b>	Ceramics Tube	
Electrode	<b>E</b>	Platinum-alumina Cemet	
Grounding Device	<b>1</b>	None	
	<b>2</b>	Grounding Rings (Select an optional code)	
Housing and Coating	<b>1</b>	Standard Material with Standard Coating	
	<b>2</b>	Standard Material with Rugged Coating	
Cable Entry	<b>0</b>	JIS G1/2 Female	
	<b>2</b>	ASME 1/2 NPT Female	
	<b>4</b>	ISO M20 x 1.5 Female	
Accuracy	<b>B</b>	Standard	
	<b>C</b>	High Grade (25 to 200 mm/1 to 8 in.)	
Power Supply	<b>-1</b>	100-240 V AC / 100-120 V DC	
	<b>-2</b>	24 V AC / DC	
	<b>-N</b>	None (Remote Sensor)	
Communication and I/O	<b>D</b> □	□: A, B, C, D, E, F, G, H, J, K BRAIN and I/O (Type A to K, See separate table)	
	<b>J</b> □	□: A, B, C, D, E, F, G, H, J, K HART 7 and I/O (Type A to K, See separate table)	
	<b>NN</b>	None (Remote Sensor)	
Transmitter Wiring Terminal	<b>1</b>	M4 Screw-type	
	<b>2</b>	Clamp Type	
	<b>N</b>	None (Remote Sensor)	
Display	<b>1</b>	With Display (English, Multi-language)	
	<b>2</b>	With Display (English, Chinese)	
	<b>N</b>	Without Display/Remote Sensor	
Optional Specification		/□ Refer to optional specification table.	



●Submersible, Wafer, PFA Lining

Model	Suffix Code		Description
AXG015			Magnetic Flowmeter (15 mm/0.5 in)
AXG025			Magnetic Flowmeter (25 mm/1 in)
AXG032			Magnetic Flowmeter (32 mm/1.25 in)
AXG040			Magnetic Flowmeter (40 mm/1.5 in)
AXG050			Magnetic Flowmeter (50 mm/2 in)
AXG065			Magnetic Flowmeter (65 mm/2.5 in)
AXG080			Magnetic Flowmeter (80 mm/3 in)
AXG100			Magnetic Flowmeter (100 mm/4 in)
AXG125			Magnetic Flowmeter (125 mm/5 in)
AXG150			Magnetic Flowmeter (150 mm/6 in)
AXG200			Magnetic Flowmeter (200 mm/8 in)
Use	<b>-W</b>		Submersible
Construction	<b>D</b>		Remote Sensor (for AXFA11)
	<b>G</b>		Remote Sensor (for AXG4A)
Explosion Protection	<b>000</b>		Non Explosion Protection Approval
Process Connection	Wafer	<b>AA1</b>	ASME Class 150 Wafer
		<b>AA2</b>	ASME Class 300 Wafer
		<b>AE1</b>	EN PN10 Wafer
		<b>AE2</b>	EN PN16 Wafer
		<b>AE4</b>	EN PN40 Wafer
		<b>AG1</b>	JIS F12 Wafer
		<b>AJ1</b>	JIS 10K Wafer
		<b>AJ2</b>	JIS 20K Wafer
		<b>AP1</b>	JPI Class 150 Wafer
Lining	<b>A</b>		PFA Lining
Electrode	<b>L</b>		Stainless Steel 316L
	<b>P</b>		Platinum-Iridium
	<b>H</b>		Nickel Alloy
	<b>T</b>		Tantalum
	<b>V</b>		Titanium
	<b>W</b>		Tungsten Carbide
Grounding Device	<b>1</b>		None
	<b>2</b>		Grounding Rings (Select an optional code)
Housing and Coating	<b>1</b>		Standard Material with Standard Coating
Cable Entry	<b>0</b>		JIS G1/2 Female
Accuracy	<b>B</b>		Standard
	<b>C</b>		High Grade (25 to 200 mm/1 to 8 in.)
Power Supply	<b>-N</b>		None (Remote Sensor)
Communication and I/O	<b>NN</b>		None (Remote Sensor)
Transmitter Wiring Terminal	<b>N</b>		None (Remote Sensor)
Display	<b>N</b>		Without Display/Remote Sensor
Optional Specification	/□ Refer to optional specification table.		

## ●Submersible, Flange, PFA Lining (15 to 400 mm/0.5 to 16 in.)

Model	Suffix Code	Description	
AXG015		Magnetic Flowmeter (15 mm/0.5 in)	
AXG025		Magnetic Flowmeter (25 mm/1 in)	
AXG032		Magnetic Flowmeter (32 mm/1.25 in)	
AXG040		Magnetic Flowmeter (40 mm/1.5 in)	
AXG050		Magnetic Flowmeter (50 mm/2 in)	
AXG065		Magnetic Flowmeter (65 mm/2.5 in)	
AXG080		Magnetic Flowmeter (80 mm/3 in)	
AXG100		Magnetic Flowmeter (100 mm/4 in)	
AXG125		Magnetic Flowmeter (125 mm/5 in)	
AXG150		Magnetic Flowmeter (150 mm/6 in)	
AXG200		Magnetic Flowmeter (200 mm/8 in)	
AXG250		Magnetic Flowmeter (250 mm/10 in)	
AXG300		Magnetic Flowmeter (300 mm/12 in)	
AXG350		Magnetic Flowmeter (350 mm/14 in)	
AXG400		Magnetic Flowmeter (400 mm/16 in)	
Use	<b>-W</b>	Submersible	
Construction	<b>D</b>	Remote Sensor (for AXFA11)	
	<b>G</b>	Remote Sensor (for AXG4A)	
Explosion Protection	<b>000</b>	Non Explosion Protection Approval	
Process Connection	Stainless Steel Flange (F304)	<b>BA1</b>	ASME Class 150 Flange
		<b>BA2</b>	ASME Class 300 Flange
		<b>BE1</b>	EN PN10 Flange
		<b>BE2</b>	EN PN16 Flange
		<b>BE4</b>	EN PN40 Flange
		<b>BG1</b>	JIS F12 Flange
		<b>BJ1</b>	JIS 10K Flange
		<b>BJ2</b>	JIS 20K Flange
		<b>BP1</b>	JPI Class 150 Flange
	Stainless Steel Flange (F316)	<b>PA1</b>	ASME Class 150 Flange
		<b>PA2</b>	ASME Class 300 Flange
		<b>PE1</b>	EN PN10 Flange
		<b>PE2</b>	EN PN16 Flange
		<b>PE4</b>	EN PN40 Flange
	Carbon Steel Flange	<b>PJ1</b>	JIS 10K Flange
		<b>CA1</b>	ASME Class 150 Flange
		<b>CA2</b>	ASME Class 300 Flange
		<b>CE1</b>	EN PN10 Flange
		<b>CE2</b>	EN PN16 Flange
		<b>CE4</b>	EN PN40 Flange
<b>CG1</b>		JIS F12 Flange	
<b>CJ1</b>	JIS 10K Flange		
<b>CJ2</b>	JIS 20K Flange		
<b>CS1</b>	AS Table D Flange		
<b>CS2</b>	AS Table E Flange		
Lining	<b>A</b>	PFA Lining	
Electrode	<b>L</b>	Stainless Steel 316L	
	<b>P</b>	Platinum-Iridium	
	<b>H</b>	Nickel Alloy	
	<b>T</b>	Tantalum	
	<b>V</b>	Titanium	
Grounding Device	<b>W</b>	Tungsten Carbide	
	<b>1</b>	None	
	<b>2</b>	Grounding Rings (Select an optional code)	
Housing and Coating	<b>3</b>	Built-in Grounding Electrodes (Select an optional code)	
	<b>1</b>	Standard Material with Standard Coating	
Cable Entry	<b>0</b>	JIS G1/2 Female	

(Continued)

Accuracy	<b>B</b>	Standard
	<b>C</b>	High Grade (25 to 200 mm/1 to 8 in.)
Power Supply	<b>-N</b>	None (Remote Sensor)
Communication and I/O	<b>NN</b>	None (Remote Sensor)
Transmitter Wiring Terminal	<b>N</b>	None (Remote Sensor)
Display	<b>N</b>	Without Display/Remote Sensor
Optional Specification		<input type="checkbox"/> Refer to optional specification table.

●Submersible, Flange, PFA Lining (500 mm/20 in.)

Model	Suffix Code		Description
<b>AXG500</b>			Magnetic Flowmeter (500 mm/20 in.)
Use	<b>-W</b>		Submersible
Construction	<b>D</b>		Remote Sensor (for AXFA11)
Explosion Protection	<b>000</b>		Non Explosion Protection Approval
Process Connection	Stainless Steel Flange (F304)	<b>BA1</b>	ASME Class 150 Flange
		<b>BE1</b>	EN PN10 Flange
		<b>BE2</b>	EN PN16 Flange
	Carbon Steel Flange	<b>CA1</b>	ASME Class 150 Flange
		<b>CE1</b>	EN PN10 Flange
		<b>CE2</b>	EN PN16 Flange
Lining	<b>A</b>		PFA Lining
Electrode	<b>L</b>		Stainless Steel 316L
	<b>H</b>		Nickel Alloy
Grounding Device	<b>1</b>		None
	<b>2</b>		Grounding Rings (Select an optional code)
Housing and Coating	<b>1</b>		Standard Material with Standard Coating
Cable Entry	<b>0</b>		JIS G1/2 Female
Accuracy	<b>B</b>		Standard
Power Supply	<b>-N</b>		None (Remote Sensor)
Communication and I/O	<b>NN</b>		None (Remote Sensor)
Transmitter Wiring Terminal	<b>N</b>		None (Remote Sensor)
Display	<b>N</b>		Without Display/Remote Sensor
Optional Specification			<input type="checkbox"/> Refer to optional specification table.

●Submersible, Flange, PFA Lining (High Pressure Type, ASME Class 600)

Model	Suffix Code		Description
AXG025			Magnetic Flowmeter (25 mm/1 in)
AXG040			Magnetic Flowmeter (40 mm/1.5 in)
AXG050			Magnetic Flowmeter (50 mm/2 in)
AXG080			Magnetic Flowmeter (80 mm/3 in)
AXG100			Magnetic Flowmeter (100 mm/4 in)
Use	<b>-W</b>		Submersible
Construction	<b>D</b>		Remote Sensor (for AXFA11)
	<b>G</b>		Remote Sensor (for AXG4A)
Explosion Protection	<b>000</b>		Non Explosion Protection Approval
Process Connection	Stainless Steel Flange (F304)	<b>EA4</b>	ASME Class 600 Flange (High Pressure)
Lining	<b>A</b>		PFA Lining
Electrode	<b>L</b>		Stainless Steel 316L
Grounding Device	<b>2</b>		Grounding Rings (Select the optional code GRN)
Housing and Coating	<b>1</b>		Standard Material with Standard Coating
Cable Entry	<b>0</b>		JIS G1/2 Female
Accuracy	<b>B</b>		Standard
Power Supply	<b>-N</b>		None (Remote Sensor)
Communication and I/O	<b>NN</b>		None (Remote Sensor)
Transmitter Wiring Terminal	<b>N</b>		None (Remote Sensor)
Display	<b>N</b>		Without Display/Remote Sensor
Optional Specification			/□ Refer to optional specification table.

## ●Hygienic, PFA Lining

Model	Suffix Code	Description	
AXG015		Magnetic Flowmeter (15 mm/0.5 in)	
AXG025		Magnetic Flowmeter (25 mm/1 in)	
AXG032		Magnetic Flowmeter (32 mm/1.25 in)	
AXG040		Magnetic Flowmeter (40 mm/1.5 in)	
AXG050		Magnetic Flowmeter (50 mm/2 in)	
AXG065		Magnetic Flowmeter (65 mm/2.5 in)	
AXG080		Magnetic Flowmeter (80 mm/3 in)	
AXG100		Magnetic Flowmeter (100 mm/4 in)	
AXG125		Magnetic Flowmeter (125 mm/5 in)	
Use	<b>-H</b>	Hygienic	
Construction	<b>A</b>	Integral Flowmeter	
	<b>D</b>	Remote Sensor (for AXFA11)	
	<b>G</b>	Remote Sensor (for AXG4A)	
Explosion Protection	<b>000</b>	Non Explosion Protection Approval	
Process Connection	Clamp	<b>HAB</b> (Stainless Steel F316L)	Tri-Clamp
		<b>HDB</b> (Stainless Steel F316L)	DIN 32676 Clamp
		<b>HKB</b> (Stainless Steel F316L)	ISO 2852 / SMS 3016 Clamp
		<b>HJA</b> (Stainless Steel F304)	ISO 2852 Clamp (for JIS G3447 Piping)
		<b>HJB</b> (Stainless Steel F316L)	ISO 2852 Clamp (for JIS G3447 Piping)
	Union	<b>JDB</b> (Stainless Steel F316L)	DIN 11851 Union
		<b>JKB</b> (Stainless Steel F316L)	ISO 2853 Union
		<b>JSB</b> (Stainless Steel F316L)	SMS 1145 Union (Open groove packing type)
		<b>JJA</b> (Stainless Steel F304)	ISO 2853 Union (for JIS G3447 Piping)
		<b>JJB</b> (Stainless Steel F316L)	ISO 2853 Union (for JIS G3447 Piping)
	Butt Weld Joint	<b>KDB</b> (Stainless Steel F316L)	DIN 11850 Piping Butt Weld Joint
		<b>KKB</b> (Stainless Steel F316L)	ISO 2037 Piping Butt Weld Joint
		<b>KJA</b> (Stainless Steel F304)	JIS G3447 Piping Butt Weld Joint
<b>KJB</b> (Stainless Steel F316L)		JIS G3447 Piping Butt Weld Joint	
Lining	<b>A</b>	PFA Lining	
Electrode	<b>L</b>	Stainless Steel 316L	
Grounding Device	<b>1</b>	None	
Housing and Coating	<b>1</b>	Standard Material with Standard Coating	
Cable Entry	<b>0</b>	JIS G1/2 Female	
	<b>2</b>	ASME 1/2 NPT Female	
	<b>4</b>	ISO M20 x 1.5 Female	
Accuracy	<b>B</b>	Standard	
	<b>C</b>	High Grade (25 to 125 mm/1 to 5 in.)	
Power Supply	<b>-1</b>	100-240 V AC / 100-120 V DC	
	<b>-2</b>	24 V AC / DC	
	<b>-N</b>	None (Remote Sensor)	
Communication and I/O	<b>D</b> <input type="checkbox"/>	<input type="checkbox"/> : A, B, C, D, E, F, G, H, J, K BRAiN and I/O (Type A to K, See separate table)	
	<b>J</b> <input type="checkbox"/>	<input type="checkbox"/> : A, B, C, D, E, F, G, H, J, K HART 7 and I/O (Type A to K, See separate table)	
	<b>NN</b>	None (Remote Sensor)	
Transmitter Wiring Terminal	<b>1</b>	M4 Screw-type	
	<b>2</b>	Clamp Type	
	<b>N</b>	None (Remote Sensor)	
Display	<b>1</b>	With Display (English, Multi-language)	
	<b>2</b>	With Display (English, Chinese)	
	<b>N</b>	Without Display/Remote Sensor	
Optional Specification		<input type="checkbox"/> Refer to optional specification table.	

### ●General-purpose, Remote Transmitter

Model	Suffix Code	Description
<b>AXG4A</b>		Magnetic Flowmeter Remote Transmitter
Use	<b>-G</b>	General-purpose
Explosion Protection	<b>000</b>	Non Explosion Protection Approval
Housing and Coating	<b>1</b>	Standard Material with Standard Coating
	<b>2</b>	Standard Material with Rugged Coating
Cable Entry	<b>0</b>	JIS G1/2 Female
	<b>2</b>	ASME 1/2 NPT Female
	<b>4</b>	ISO M20 x 1.5 Female
Power Supply	<b>1</b>	100-240 V AC / 100-120 V DC
	<b>2</b>	24 V AC / DC
Communication and I/O	<b>D□</b>	□: A, B, C, D, E, F, G, H, J, K BRAIN and I/O (Type A to K, See separate table)
	<b>J□</b>	□: A, B, C, D, E, F, G, H, J, K HART 7 and I/O (Type A to K, See separate table)
Transmitter Wiring Terminal	<b>1</b>	M4 Screw-type
	<b>2</b>	Clamp Type
Display	<b>1</b>	With Display (English, Multi-language)
	<b>2</b>	With Display (English, Chinese)
	<b>N</b>	Without Display
Optional Specification		/□ Refer to optional specification table.

### ●Signal Cable

Model	Suffix Code	Optional Code	Description
<b>AX01C</b>			Magnetic Flowmeter Signal Cable
Cable Finish and Length	<b>-A□□□ (*1)</b>		Unfinished, Cable length □□□ m, Set of Finishing Parts for M4 Screws
	<b>-C□□□ (*1)</b>		Finished for AXG4A, Cable Length □□□ m
	<b>-D□□□ (*1)</b>		Finished for AXFA11, Cable Length □□□ m
Finishing Parts		<b>/C□ (*2)</b>	Finishing Parts (□ sets)

\*1: Specify the cable length in the "□□□" with the numerical value three digits (001 to 200) as multiple of 1 meter (e.g. 001, 002, or 005) for a length up to 5 m, as multiple of 5 meters up to 100 m (e.g. 010, 020, or 100), or as multiple of 10 meters up to 200 m (e.g. 110, 120, or 200).  
The maximum cable length: -A□□□: 200 m, -C□□□: 100 m, -D□□□: 200 m

\*2: Specify the finishing parts quantity in the "□" with the numerical value one digit (1 to 9).



●Details: Communication and I/O

Type	Communication and I/O Code		Number of Input and Output							
			Current Output (Active)	Pulse/ Status Output (Passive)	Status Input (No-voltage)	Status Output (Passive)	Pulse/ Status Output (Active, with internal resistor)	Pulse/ Status Output (Active, without internal resistor)	Current Output (Passive)	Current Input (Active)
	BRAIN	HART 7								
Type A	DA	JA	1	1	—	—	—	—	—	—
Type B	DB	JB	2	2	—	—	—	—	—	—
Type C	DC	JC	2	1	1	—	—	—	—	—
Type D	DD	JD	1	2	—	1	—	—	—	—
Type E	DE	JE	1	2	1	—	—	—	—	—
Type F	DF	JF	1	1	1	—	1	—	—	—
Type G	DG	JG	1	1	1	—	—	1	—	—
Type H	DH	JH	1	1	—	—	—	—	1	1
Type J	DJ	JJ	1	2	—	—	—	—	—	1
Type K	DK	JK	1	1	1	—	—	—	—	1

■ **OPTIONAL CODE**

● **Application, Usage, and Operating Function**

●: Applicable —: Not Applicable

Item	Specification and Applicable Condition	Applicable Model						Code
		General-purpose		Submersible	Hygienic		General-purpose	
		Integral Flowmeter	Remote Sensor	Remote Sensor	Integral Flowmeter	Remote Sensor	Remote Transmitter	
Mirror Finished PFA (for adhesive fluid)	Finish the inner surface of the PFA lining (sizes 15 to 400 mm (0.5 to 16 in.), except for high pressure type) to a mirror finish. The Ra is average of measured values on several points. Sizes 15 to 200 mm (0.5 to 8 in.): Ra 0.05 to 0.15 μm Sizes 250 to 400 mm (10 to 16 in.): Ra 0.05 to 0.25 μm	●	●	●	●	●	—	PM
Mirror Finished Ceramics (for adhesive fluid)	Finish the inner surface of the ceramics tube (5 to 200 mm (0.2 to 8 in.)) to a mirror finish with Ra 0.1 μm or less. The Ra is average of measured values on several points.	●	●	—	—	—	—	CM
Vent Hole (for permeable fluid)	For permeable fluid applications (e.g. nitric acid, hydrofluoric acid, high temperature sodium hydroxide, black liquor etc.). A vent hole is provided for letting fluid permeated between the lining and the measuring pipe escape. Applicable for flange type of PFA lining except for high pressure type.	●	●	—	—	—	—	H
DC Noise Cut Circuit (for electrolytic bath)	Built-in DC noise cut circuit. It works effectively when the size is 15 mm (0.5 in.) or more and fluid conductivity is 50 μS/cm or more. Empty pipe detection, electrode adhesion diagnosis, electrode potential measurement, and wetted resistance measurement function can not be used. For remote transmitter, it must be combined with remote sensor of size 15 mm (0.5 in.) or more.	●	—	—	●	—	●	ELC
Potting Terminal Box with Cable (For district heating and cooling or condensation-proof)	Urethane resin potting is applied in the terminal box of a remote sensor. Signal and excitation cables (when optional code L□□□ is not selected, cable length is each 30 m) are pre-wired and waterproof glands with union joints are attached at factory. For cable entry, selection of JIS G1/2 female thread is necessary. When optional code DHC is selected, the optional code of plastic and waterproof glands can not be selected.	—	●	—	—	●	—	DHC
Signal and Excitation Cable Length	Change the length of signal cable and excitation cable pre-wired for a remote sensor of Submersible or one with optional code DHC. Specify the cable length in the "□□□" with the numerical value three digits (001 to 200) as multiple of 1 meter (e.g. 001, 002, or 005) for a length up to 5 m, as multiple of 5 meters up to 100 m (e.g. 010, 020, or 100), or as multiple of 10 meters up to 200 m (e.g. 110, 120, or 200). The maximum cable length is 100 m in combination with the AXG4A transmitter, and 200 m in combination with the AXFA11 transmitter. When optional code L□□□ is not selected, a 30-meter length cable is pre-wired.	—	●	●	—	●	—	L□□□
Oil Prohibited Use	Electrodes, linings, grounding devices (grounding rings plate type, grounding rings electrode type, built-in grounding electrodes), gaskets, and piping adapters and connection parts (for Hygienic) of sizes 2.5 to 400 mm (0.1 to 16 in.) are assembled and packed with polyethylene after being cleaned with water and acetone and dried with air. The label "OIL FREE" is affixed.	●	●	—	●	●	—	K1
Oil Prohibited Use with Dehydration	Electrodes, linings, and grounding devices (grounding rings plate type, grounding rings electrode type, built-in grounding electrodes) of sizes 2.5 to 400 mm (0.1 to 16 in.) are assembled and packed with polyethylene including desiccants after being cleaned with water and acetone and dried with air. The label "OIL & WATER FREE" is affixed.	●	●	—	—	—	—	K5

●Application, Usage, and Operating Function (Continued)

●: Applicable —: Not Applicable

Item	Specification and Applicable Condition	Applicable Model						Code
		General-purpose		Submersible	Hygienic		General-purpose	
		Integral Flowmeter	Remote Sensor	Remote Sensor	Integral Flowmeter	Remote Sensor	Remote Transmitter	
Mass Unit Setting	The flow rate calculation is performed in mass unit. In addition to fluid density, specify span flow rate, pulse weight, and totalization weight in mass unit. For specifying procedures, read "Ordering Information". For remote sensor, specified parameters are set in the transmitter that is ordered in combination.	●	●	●	●	●	—	MU
Signal Down on Failure	Set the current output signal as follows when shipped. Output signal at CPU failure or alarm occurrence: 2.4 mA (–10 %) or less (The standard setting is 21.6 mA (110%) or more at CPU failure or alarm occurrence.)	●	—	—	●	—	●	C1
Signal Down on Failure (NAMUR NE 43 Compliant)	Set the current output signal as follows when shipped. Output signal limits: 3.8 to 20.5 mA Output signal at CPU failure or alarm occurrence: Low: 2.4 mA (–10%) or less	●	—	—	●	—	●	C2
Signal Up on Failure (NAMUR NE 43 Compliant)	Set the current output signal as follows when shipped. Output signal limits: 3.8 to 20.5 mA Output signal at CPU failure or alarm occurrence: High: 21.6 mA (110%) or more	●	—	—	●	—	●	C3
microSD Card	A microSD card slot is added to the display unit, and a microSD card (capacity 1 GB, format FAT 16) is inserted when shipped. When using parameter store / restore function, and/or data logging function, specify optional code MC.	●	—	—	●	—	●	MC

●Tag Plate and Mounting Bracket

●: Applicable —: Not Applicable

Item	Specification and Applicable Condition	Applicable Model						Code
		General-purpose		Submersible	Hygienic		General-purpose	
		Integral Flowmeter	Remote Sensor	Remote Sensor	Integral Flowmeter	Remote Sensor	Remote Transmitter	
Stainless Steel Tag Plate	The pendant type tag plate (stainless steel 304) is wired around the flowmeter neck. Select optional code SCT when necessary in addition to that on the nameplate, on which the Tag No. is inscribed. Plate size (Height x Width): Approx. 12.5 mm x 40 mm (4.92 in. x 15.7 in.)	●	●	●	●	●	●	SCT
Stainless Steel Mounting Bracket	Change the material of the remote transmitter mounting bracket, from carbon steel to stainless steel 304.	—	—	—	—	—	●	SB

●Piping Parts

●: Applicable —: Not Applicable

Item	Specification and Applicable Condition	Applicable Model					Code
		General-purpose		Submersible	Hygienic		
		Integral Flowmeter	Remote Sensor	Remote Sensor	Integral Flowmeter	Remote Sensor	
Bolts, Nuts and Gaskets (Type C)	The mounting bolts, nuts and gaskets of wafer type (process connection code: AJ1, AJ2, AA1) are supplied. For PFA lining and ceramics tube, there is a risk of liquid leakage due to the difference in elasticity from chloroprene rubber gasket, so it is recommended to specify an optional code GA, GC, or GD together. Bolt: Stainless steel 304 Nut: Stainless steel 304 Gasket(*): Chloroprene rubber (CR), thickness: 3 mm (0.12 in.) *: The allowable temperature and pressure is equivalent to that of Valqua #2010 series.	●	●	●	—	—	BSC
Bolts, Nuts and Gaskets (Type F)	The mounting bolts, nuts and gaskets of wafer type (process connection code: AJ1, AJ2, AA1) are supplied. Bolt: Stainless steel 304 Nut: Stainless steel 304 Gasket(*): PTFE-sheathed non-asbestos joint sheet, thickness: 3 mm (0.12 in.) *: The allowable temperature and pressure is equivalent to that of Valqua #7030 (S) series.	●	●	●	—	—	BSF
Hygienic Connection Parts	Connection parts for hygienic are supplied. Optional code W2 can be selected with the following process connection codes. HJA: Clamp: Stainless steel SCS13 Ferrule: Size 15 mm (0.5 in.): Stainless steel 316L Sizes 25 to 125 mm (1 to 5 in.): Stainless steel 304 Gasket: Ethylene propylene diene rubber (EPDM) (*) HJB: Clamp: Stainless steel SCS13 Ferrule: Stainless steel 316L Gasket: Ethylene propylene diene rubber (EPDM) (*) JJA: Nut: Stainless steel 304 Sleeve: Stainless steel 304 Gasket: Ethylene propylene diene rubber (EPDM) (*) JJB: Nut: Stainless steel 304 Sleeve: Stainless steel F316L Gasket: Ethylene propylene diene rubber (EPDM) (*) *: The gasket material is silicone rubber, when size 125 mm (5 in.) or optional code GH is selected.	—	—	—	●	●	W2

●Grounding Device

Grounding devices are attached at factory.

For the applicable condition of grounding devices and gaskets, see the separate table.

●: Applicable —: Not Applicable

Item	Specification and Applicable Condition	Applicable Model					Code
		General-purpose		Submersible	Hygienic		
		Integral Flowmeter	Remote Sensor	Remote Sensor	Integral Flowmeter	Remote Sensor	
Grounding Rings (Plate Type L)	Material: Stainless Steel 316L, Thin Type. Thickness: 1 mm (0.04 in.) for sizes 2.5 to 200 mm (0.1 to 8 in.) 2 mm (0.08 in.) for sizes 250 to 400 mm (10 to 16 in.)	●	●	●	—	—	GRL
Grounding Rings (Plate Type N)	Material: Stainless Steel 316L, Thick Type. Thickness: Except for high pressure type (ASME Class 600 flange): 3 mm (0.12 in.) for sizes 2.5 to 400 mm (0.1 to 16 in.) 4 mm (0.16 in.) for size 500 mm (20 in.) For high pressure type (ASME Class 600 flange): 8.5 mm (0.33 in.) for size 25 mm (1 in.) 10.5 mm (0.41 in.) for sizes 40 to 100 mm (1.5 to 4 in.)	●	●	●	—	—	GRN
Grounding Rings (Plate Type H)	Material: Nickel Alloy, Thin Type. Thickness: 1 mm (0.04 in.) for sizes 2.5 to 200 mm (0.1 to 8 in.) 2 mm (0.08 in.) for sizes 250 to 400 mm (10 to 16 in.)	●	●	●	—	—	GRH
Grounding Rings (Plate Type J)	Material: Nickel Alloy, Thick Type. Thickness: 3 mm (0.12 in.) for sizes 2.5 to 400 mm (0.1 to 16 in.) 4 mm (0.16 in.) for size 500 mm (20 in.)	●	●	●	—	—	GRJ
Grounding Rings (Plate Type V)	Material: Titanium, Thin Type. Thickness: 1 mm (0.04 in.) for sizes 2.5 to 200 mm (0.1 to 8 in.) 2 mm (0.08 in.) for sizes 250 to 400 mm (10 to 16 in.)	●	●	●	—	—	GRV
Grounding Rings (Plate Type W)	Material: Titanium, Thick Type. Thickness: 3 mm (0.12 in.) for sizes 2.5 to 400 mm (0.1 to 16 in.)	●	●	●	—	—	GRW
Grounding Rings (Electrode Type P)	Material: Platinum-Iridium Width: 14 mm (0.55 in.) for sizes 2.5 to 125 mm (0.1 to 5 in.) 16 mm (0.63 in.) for sizes 150 to 200 mm (6 to 8 in.)	●	●	●	—	—	GRP
Grounding Rings (Electrode Type T)	Material: Tantalum Width: 14 mm (0.55 in.) for sizes 2.5 to 125 mm (0.1 to 5 in.) 16 mm (0.63 in.) for sizes 150 to 200 mm (6 to 8 in.)	●	●	●	—	—	GRT
Built-in Grounding Electrodes (Type P)	Material: Platinum-Iridium For electrode material selected by the suffix code, selection of platinum-iridium is necessary.	●	●	●	—	—	GBP
Built-in Grounding Electrodes (Type T)	Material: Tantalum For electrode material selected by the suffix code, selection of tantalum is necessary.	●	●	●	—	—	GBT

●Gasket

Grounding devices are attached at factory.

For applicable condition of grounding devices and gaskets, see the separate table.

●: Applicable —: Not Applicable

Item	Specification and Applicable Condition	Applicable Model					Code
		General-purpose		Submersible	Hygienic		
		Integral Flowmeter	Remote Sensor	Remote Sensor	Integral Flowmeter	Remote Sensor	
Plastic Pipe Gaskets	Fluororubber gasket (Viton) for plastic piping such as PVC. The allowable temperature and pressure range is the same as those of Valqua #4010 with no special formulation.	●	●	●	—	—	GA
Plastic Pipe Acid-resistant Gaskets	Acid-resistant fluororubber gasket (Viton) for plastic piping such as PVC. The allowable temperature and pressure range is the same as those of Valqua #4010 with special formulation D2470.	●	●	●	—	—	GC
Plastic Pipe Alkali-resistant Gaskets	Alkali-resistant fluororubber gasket (Viton) for plastic piping such as PVC. The allowable temperature and pressure range is the same as those of Valqua #4010 with special formulation D0970.	●	●	●	—	—	GD
Metal Pipe Alkali-resistant Gaskets	Alkali-resistant (fluorocarbon resin containing carbon) gasket for metal piping. The allowable temperature and pressure range is the same as those of Valqua #7026.	●	●	—	—	—	GF
Hygienic Use Silicone Rubber Gaskets	For Hygienic (sizes 15 to 25, and 40 to 125 mm (0.5 to 1, and 1.5 to 5 in.)), change the material of the gasket fixed between the measuring pipe and piping connection adapter from ethylene propylene diene rubber (EPDM) to silicone rubber. Select optional code GH, when the fluid temperature is 120 °C (248 °F) or more (Maximum: 160 °C (320 °F)),	—	—	—	●	●	GH

●Details: Applicable Condition for Grounding Devices and Gaskets

●: Applicable —: Not Applicable

Lining	PFA Lining														Ceramics Tube					
	Flange											Wafer	Clamp Union Butt Weld Joint	Union Joint		Wafer				
	Except for High Pressure Type										High Pressure Type									
Size mm (inch)	2.5 to 15 (0.1 to 0.5)		25 to 125 (1 to 5)		150 to 200 (6 to 8)		250 to 400 (10 to 16)		500 (20)		25 to 100 (1 to 4)		2.5 to 200 (0.1 to 8)		15 to 125 (0.5 to 5)		2.5 to 10 (0.1 to 0.4)		15 to 200 (0.5 to 8)	
Code (Gasket)	Not selected	GA GC GD	Not selected	GA GC GD	Not selected	GA GC GD	Not selected	GA GC GD	Not selected	GA GC GD	Not selected	GA GC GD	Not selected	GA GC GD	Not selected	GH	Not selected	GF	Not selected	GA GC GD GF
Not selected	●	—	●	—	●	—	●	—	●	—	—	—	●	—	●	●	●	●	●	—
GRL	●	—	●	—	●	—	●	—	—	—	—	—	●	—	—	—	—	—	—	—
GRN	—	●	●	●	●	●	●	—	●	—	●	—	—	●	—	—	—	—	●	●
GRH	●	—	●	—	●	—	●	—	—	—	—	—	●	—	—	—	—	—	—	—
GRJ	—	●	●	●	●	●	●	—	●	—	—	—	—	●	—	—	—	—	●	●
GRV	●	—	●	—	●	—	●	—	—	—	—	—	●	—	—	—	—	—	—	—
GRW	—	●	●	●	●	●	●	—	—	—	—	—	—	●	—	—	—	—	●	●
GRP	●	●	●	●	●	●	—	—	—	—	—	—	●	●	—	—	—	—	●	●
GRT	●	●	●	●	●	●	—	—	—	—	—	—	●	●	—	—	—	—	●	●
GBP	—	—	—	—	●	—	●	—	—	—	—	—	—	—	—	—	—	—	—	—
GBT	—	—	—	—	●	—	●	—	—	—	—	—	—	—	—	—	—	—	—	—

## ●Direction of Cable Entry, Waterproof and Plastic Glands

●: Applicable —: Not Applicable

Item	Specification and Applicable Condition	Applicable Model						Code
		General-purpose		Submersible	Hygienic		General-purpose	
		Integral Flowmeter	Remote Sensor	Remote Sensor	Integral Flowmeter	Remote Sensor	Remote Transmitter	
Cable Entry Direction Change	Rotate the transmitter of integral flowmeter or the terminal box of remote sensor and change the direction of the cable entry (+90, +180, or -90 degree). For specifying procedures, read "Ordering Information".	●	●	●	●	●	—	RH
Waterproof Glands (Type G)	2 pcs. of waterproof gland For cable entry, selection of JIS G1/2 female thread is necessary.	—	●	—	—	●	—	EG
Waterproof Glands (Type G2)	2 pcs. of waterproof gland, and a blanking plug For cable entry, selection of JIS G1/2 female thread is necessary.	●	—	—	●	—	—	EG2
Waterproof Glands (Type G3)	3 pcs. of waterproof gland For cable entry, selection of JIS G1/2 female thread is necessary.	●	—	—	●	—	—	EG3
Waterproof Glands (Type G4)	4 pcs. of waterproof gland, and a blanking plug For cable entry, selection of JIS G1/2 female thread is necessary.	—	—	—	—	—	●	EG4
Waterproof Glands (Type G5)	5 pcs. of waterproof gland For cable entry, selection of JIS G1/2 female thread is necessary.	—	—	—	—	—	●	EG5
Waterproof Glands (Type U)	2 pcs. of waterproof gland with union joint For cable entry, selection of JIS G1/2 female thread is necessary.	—	●	—	—	●	—	EU
Waterproof Glands (Type U2)	2 pcs. of waterproof gland with union joint, and a blanking plug For cable entry, selection of JIS G1/2 female thread is necessary.	●	—	—	●	—	—	EU2
Waterproof Glands (Type U3)	3 pcs. of waterproof gland with union joint For cable entry, selection of JIS G1/2 female thread is necessary.	●	—	—	●	—	—	EU3
Waterproof Glands (Type U4)	4 pcs. of waterproof gland with union joint, and a blanking plug For cable entry, selection of JIS G1/2 female thread is necessary.	—	—	—	—	—	●	EU4
Waterproof Glands (Type U5)	5 pcs. of waterproof gland with union joint For cable entry, selection of JIS G1/2 female thread is necessary.	—	—	—	—	—	●	EU5
Plastic Glands (Type P)	2 pcs. of plastic gland For cable entry, selection of JIS G1/2 female thread is necessary.	—	●	—	—	●	—	EP
Plastic Glands (Type P2)	2 pcs. of plastic gland, and a blanking plug For cable entry, selection of JIS G1/2 female thread is necessary.	●	—	—	●	—	—	EP2
Plastic Glands (Type P3)	3 pcs. of plastic gland For cable entry, selection of JIS G1/2 female thread is necessary.	●	—	—	●	—	—	EP3
Plastic Glands (Type P4)	4 pcs. of plastic gland, and a blanking plug For cable entry, selection of JIS G1/2 female thread is necessary.	—	—	—	—	—	●	EP4
Plastic Glands (Type P5)	5 pcs. of plastic gland For cable entry, selection of JIS G1/2 female thread is necessary.	—	—	—	—	—	●	EP5
Waterproof Glands (Type W)	2 pcs. of waterproof gland with JIS G3/4 female For cable entry, selection of JIS G1/2 female thread is necessary.	—	●	—	—	●	—	EW



●Certificate, Calibration, and Various Test

●: Applicable —: Not Applicable

Item	Specification and Applicable Condition	Applicable Model						Code
		General-purpose		Submersible	Hygienic		General-purpose	
		Integral Flowmeter	Remote Sensor	Remote Sensor	Integral Flowmeter	Remote Sensor	Remote Transmitter	
Material Certificate	Material certificate is issued. Target Parts: PFA Lining: Measuring Pipe, Electrodes, Grounding Devices (Grounding Rings Plate Type, Grounding Rings Electrode Type, or Built-in Grounding Electrodes), Flanges (for flange type), Mini-flanges (for wafer type), Adapters for Hygienic Ceramics Tube: Ceramics Tube: Grounding Devices (Grounding Rings Plate Type, or Grounding Rings Electrode Type), Union Joint	●	●	●	●	●	—	M01
Material Certificate (EN 10204-3.1)	For sizes 2.5 to 400 mm (0.1 to 16 in.), except for high pressure type, material certificates according to EN 10204 Type 3.1 with a dedicated cover is issued. The target parts are the same as optional code M01.	●	●	●	●	●	—	E01
Calibration Certificate (Level 2)	The Declaration and the Calibration Equipment List are issued.	●	●	●	●	●	●	L2
Calibration Certificate (Level 3)	The Declaration and the Primary Standard List are issued.	●	●	●	●	●	●	L3
Calibration Certificate (Level 4)	The Declaration and the Yokogawa Measuring Instruments Control System are issued.	●	●	●	●	●	●	L4
Specified Span Five-point Calibration	With the customer's specified span, the actual flow inspection of 5 points around 0, 25, 50, 75, and 100% is performed. Instead of the flow inspection at the standard flow rate of 2 m/s (6.56 ft/s), the result of flow inspection with the customer specified span is described in a test certificate (QIC). For specifiable spans, read "Ordering Information".	●	●	●	●	●	—	SC
Hydrostatic Test	The water pressure depending on the process connection is applied to the lining (measuring pipe) for 10 minutes to check that there is no leakage, and the result is described in a test certificate (QIC). For the test water pressure on each process connection, see the separate table.	●	●	●	—	—	—	T01
Withstand Voltage Test (Type 1)	Withstand voltage test on remote sensor (sizes 2.5 to 400 mm (0.1 to 16 in.)) is performed, and the result is described in a test certificate (QIC). WT1: Between excitation current terminal and ground terminal: 1000 V AC for 1 minute	—	●	●	—	●	—	WT1
Withstand Voltage Test (Type 2)	WT2: Between excitation current terminal and ground terminal: 1500 V AC for 1 minute Between signal terminals and excitation current terminal: 1500 V AC for 1 minute	—	●	●	—	●	—	WT2
PMI Test (Type 1)	Fluorescent X-ray analysis of nickel, chromium and molybdenum is performed on parts made of stainless steel or nickel alloy, and a test report is issued. For applicable condition, see the separate table. Target Parts: PM1: Grounding Rings (Plate Type) PM2: Flange (Stainless steel only) PM3: Measuring Pipe	●	●	●	—	—	—	PM1
PMI Test (Type 2)		●	●	●	—	—	—	PM2
PMI Test (Type 3)		●	●	●	●	●	—	PM3
Liquid Penetrant Test	Liquid penetrant test on welded parts of flanges (for flange type) or mini-flanges (for wafer type) is performed and a test report is issued. For applicable condition, see the separate table.	●	●	●	—	—	—	PT

●Details: Water Pressure of Hydrostatic Test (Optional Code T01):

Process connection code	Process connection	Size: mm (in.)	Water pressure (MPa)
□A1	ASME Class 150	2.5 to 300 (0.1 to 12)	3.0
		350 to 500 (14 to 20)	1.5
□A2	ASME Class 300	2.5 to 50 (0.1 to 2)	6.0
		65 to 300 (2.5 to 12)	3.0
□A4	ASME Class 600	25 to 100 (1 to 4)	15.5
□E1	EN PN10	200 to 500 (8 to 20)	1.5
□E2	EN PN16	65 to 300 (2.5 to 12)	2.4
		500 (20)	1.5
□E4	EN PN40	2.5 to 50 (0.1 to 2)	6.0
□G1	JIS F12	80 to 300 (3 to 12)	1.8
		350 to 400 (14 to 16)	1.5
□J1	JIS 10K	2.5 to 300 (0.1 to 12)	2.1
		350 to 400 (14 to 16)	1.5
□J2	JIS 20K	2.5 to 50 (0.1 to 2)	6.0
		65 to 300 (2.5 to 12)	3.0
□P1	JPI Class 150	2.5 to 300 (0.1 to 12)	3.0
		350 to 400 (14 to 16)	1.5
□S1	AS Table D	50 to 400 (2 to 16)	1.1
□S2	AS Table E	50 to 300 (2 to 12)	2.1
GU□	Union Joint	2.5 to 10 (0.1 to 0.4)	6.0

●Details: Applicable Condition for PMI Test

○Grounding Rings (Plate Type) (Optional Code PM1)

●: Applicable —: Not Applicable

Lining	PFA Lining				Ceramics Tube	
	Flange		Wafer	Clamp Union Butt Weld Joint	Union Joint	Wafer
Code (Grounding Device) / Size mm (inch)	2.5 to 400 (0.1 to 16)	500 (20)	2.5 to 200 (0.1 to 16)	15 to 125 (0.5 to 5)	2.5 to 10 (0.1 to 0.4)	15 to 200 (0.5 to 8)
Not selected	—	—	—	—	—	—
GRL	●	—	●	—	—	—
GRN	●	—	●	—	—	●
GRH	●	—	●	—	—	—
GRJ	●	—	●	—	—	●
GRV	—	—	—	—	—	—
GRW	—	—	—	—	—	—

○Flange (Optional Code PM2)

●: Applicable —: Not Applicable

Lining		PFA Lining						Ceramics Tube		
Process Connection		Flange					Wafer	Clamp Union Butt Weld Joint	Union Joint	Wafer
Size mm (inch)	Code (Process Connection)	B□□	C□□	D□□	E□□	P□□	A□□	H□□ J□□ K□□	G□□	A□□
	2.5 (0.1)		●	—	●	—	●	—	—	—
5 (0.2)		●	—	●	—	●	—	—	—	—
10 (0.4)		●	—	●	—	●	—	—	—	—
15 (0.5)		●	—	—	—	●	—	—	—	—
25 (1)		●	—	—	●	●	—	—	—	—
32 (1.25)		●	—	—	—	—	—	—	—	—
40 (1.5)		●	—	—	●	●	—	—	—	—
50 (2)		●	—	—	●	●	—	—	—	—
65 (2.5)		●	—	—	—	—	—	—	—	—
80 (3)		●	—	—	●	●	—	—	—	—
100 (4)		●	—	—	●	●	—	—	—	—
125 (5)		●	—	—	—	—	—	—	—	—
150 (6)		●	—	—	—	●	—	—	—	—
200 (8)		●	—	—	—	●	—	—	—	—
250 (10)		●	—	—	—	●	—	—	—	—
300 (12)		●	—	—	—	●	—	—	—	—
350 (14)		●	—	—	—	●	—	—	—	—
400 (16)		●	—	—	—	●	—	—	—	—
500 (20)		—	—	—	—	—	—	—	—	—

○Measuring Pipe (Optional Code PM3)

●: Applicable —: Not Applicable

Lining Size mm (inch)	Process Connection	PFA Lining			Ceramics Tube	
		Flange	Wafer	Clamp Union Butt Weld Joint	Union Joint	Wafer
2.5 (0.1)		●	●	—	—	—
5 (0.2)		●	●	—	—	—
10 (0.4)		●	●	—	—	—
15 (0.5)		●	●	●	—	—
25 (1)		●	●	●	—	—
32 (1.25)		●	●	●	—	—
40 (1.5)		●	●	●	—	—
50 (2)		●	●	●	—	—
65 (2.5)		●	●	●	—	—
80 (3)		●	●	●	—	—
100 (4)		●	●	●	—	—
125 (5)		●	●	●	—	—
150 (6)		●	●	—	—	—
200 (8)		●	●	—	—	—
250 (10)		●	—	—	—	—
300 (12)		●	—	—	—	—
350 (14)		●	—	—	—	—
400 (16)		●	—	—	—	—
500 (20)		—	—	—	—	—

●Details: Applicable Condition for Liquid Penetrant Test (Optional Code PT)

●: Applicable —: Not Applicable

Lining Size mm (inch)	Process Connection Code (Process Connection)	PFA Lining						Ceramics Tube		
		Flange					Wafer	Clamp Union Butt Weld Joint	Union Joint	Wafer
		B□□	C□□	D□□	E□□	P□□	A□□	H□□ J□□ K□□	G□□	A□□
2.5 (0.1)		—	—	—	—	—	—	—	—	—
5 (0.2)		—	—	—	—	—	—	—	—	—
10 (0.4)		—	—	—	—	—	—	—	—	—
15 (0.5)		—	—	—	—	—	—	—	—	—
25 (1)		●	—	—	●	●	—	—	—	—
32 (1.25)		●	—	—	—	—	—	—	—	—
40 (1.5)		●	—	—	●	●	—	—	—	—
50 (2)		●	●	—	●	●	—	—	—	—
65 (2.5)		●	●	—	—	—	—	—	—	—
80 (3)		●	●	—	●	●	—	—	—	—
100 (4)		●	●	—	●	●	—	—	—	—
125 (5)		●	●	—	—	—	—	—	—	—
150 (6)		●	●	—	—	●	●	—	—	—
200 (8)		●	●	—	—	●	●	—	—	—
250 (10)		●	●	—	—	●	—	—	—	—
300 (12)		●	●	—	—	●	—	—	—	—
350 (14)		●	●	—	—	●	—	—	—	—
400 (16)		●	●	—	—	●	—	—	—	—
500 (20)		●	●	—	—	—	—	—	—	—

### ■ ACCESSORIES

- Centering Device (wafer type only): 1 set
  - Blanking Plug: 1 to 2 pcs.
  - Gasket (sensor side): 2 sheets
  - Mounting Bracket (transmitter only): 1 set
- Note: Accessories differ depending on specifications to be selected.

### ■ TERMINAL CONFIGURATION

#### Remote Sensor:

<To be wired to Remote Transmitter>

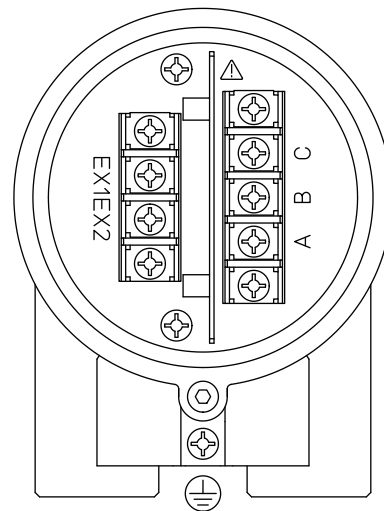

Terminal Symbol	Description
A B C	Flow Signal Output
EX1 EX2	Excitation Current Input
⊕	Protective Grounding (Outside of the terminal box)

F28.ai

Note: When submersible use or optional code DHC is selected, waterproof glands with union joints and cables are attached.

#### Remote Transmitter:

<To be wired to Remote Sensor>

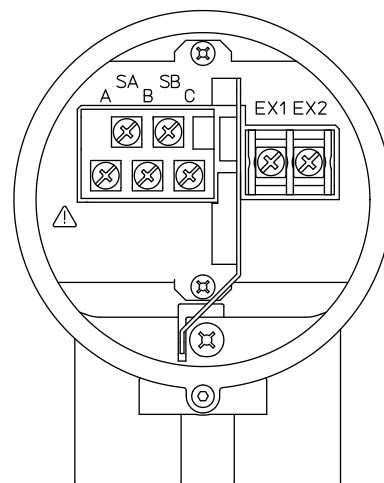

Terminal Symbol	Description
SA SB A B C	Flow Signal Input
EX1 EX2	Excitation Current Output

F29.ai

**Integral Flowmeter and Remote Transmitter:**

<To be wired to Power Supply and I/Os>

**M4 Screw Type**

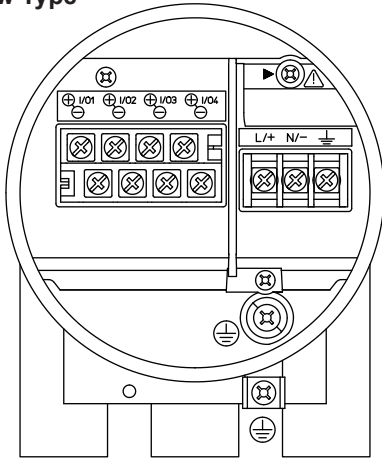

**Clamp Type**

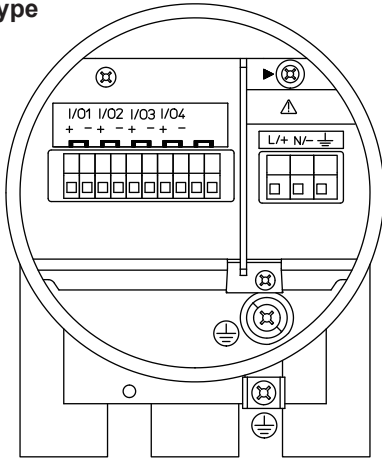

**Recommended Cable for Excitation, Power and Input / Output:**

- JIS C 3401 control cable equivalent
- JIS C 3312 power cable equivalent
- 14 AWG Belden 8720 equivalent

**Outer Diameter:**

Without gland:

6.5 to 12 mm (0.26 to 0.47 in.)

With waterproof gland (optional code EG, EG□, EU, EU□, EW):

For excitation cable:  
10.5 or 11.5 mm (0.41 or 0.45 in.)

For power and input/output cable:  
7.5 to 12 mm (0.30 to 0.47 in.)

With plastic gland (optional code EP, EP□):  
6 to 12 mm (0.24 to 0.47 in.)

**Nominal Cross Section:**

Single wire: 0.5 to 2.5 mm<sup>2</sup>

Stranded wire: 0.5 to 1.5 mm<sup>2</sup>

**Excitation Cable for Submersible Use and Optional Code DHC:**

- Heat resistant vinyl resin sheath cable
- Outer diameter ø10.5 mm (0.41 in.)

Terminal Symbol	Description
▶	Shorting Screw (Need to be fixed for normal operation)
⏏	Functional Grounding
N/ L/+	Power Supply
I/O4 - I/O4 + I/O3 - I/O3 + I/O2 - I/O2 + I/O1 - I/O1 +	Selected Input/Output (Note)  Pulse/Status Output 1  Current Output 1
⏏	Protective Grounding (Inside and outside of the terminal box)

F30.ai

Note: Read "Functions" for the input/output signal of I/O3 and I/O4 terminals.

■ DIMENSIONAL DRAWINGS

<b>List of Drawings</b>	
(1) Integral Flowmeter, Remote Sensor	P.49
Wafer (PFA Lining)	P.49
Flange (PFA Lining, excluding High Pressure Type)	P.51
- ASME Class 150	P.53
- ASME Class 300	P.54
- EN PN16, EN PN40	P.55
- EN PN10	P.56
- JIS F12	P.57
- JIS 10K	P.58
- JIS 20K	P.59
- JPI Class 150	P.60
- AS Table D	P.61
- AS Table E	P.62
Flange (PFA Lining, High Pressure Type)	P.63
- ASME Class 600	P.64
Ceramics Tube (Union Joint)	P.65
Ceramics Tube (Wafer)	P.66
Hygienic Use (Clamp, PFA Lining)	P.68
Hygienic Use (Union, PFA Lining)	P.71
Hygienic Use (Butt Weld Joint, PFA Lining)	P.75
(2) AXG4A Remote Transmitter	P.77
(3) AX01C Magnetic Flowmeter Signal Cable	P.78
(4) Dimensional Tolerance	P.79





Unit: mm (approx. in.)

Model	Process Connection Code	AA1, AA2, AJ1, AJ2														
		AE4							AE2							
		-	-	-	-	-	-	-	-	-	-	-	-	-	-	
		-	-	-	-	-	-	-	-	-	-	-	-	-	-	
		AP1							AP1							
Size Code	002	005	010	015	025	032	040	050	065	080	100	125	150	200		
Size	2.5 (0.1)	5 (0.2)	10 (0.4)	15 (0.5)	25 (1)	32 (1.25)	40 (1.5)	50 (2)	65 (2.5)	80 (3)	100 (4)	125 (5)	150 (6)	200 (8)		
Lining Code	A	A	A	A	A	A	A	A	A	A	A	A	A	A		
Remote Sensor	Lay Length (*1)	L	79 (3.11)	79 (3.11)	79 (3.11)	79 (3.11)	58 (2.30)	68 (2.69)	68 (2.69)	78 (3.09)	98 (3.87)	118 (4.66)	148 (5.84)	198 (7.81)	247 (9.70)	
	Outer Diameter	øD	44 (1.73)	44 (1.73)	44 (1.73)	44 (1.73)	68 (2.66)	73 (2.87)	86 (3.39)	99 (3.90)	117 (4.61)	129 (5.08)	155 (6.10)	183 (7.20)	252 (9.91)	
	Lining Inner Diameter	ød	2 (0.09)	5 (0.19)	8 (0.30)	13 (0.51)	24 (0.93)	29 (1.13)	37 (1.44)	49 (1.94)	61 (2.40)	73 (2.87)	97 (3.82)	121 (4.76)	145 (5.72)	194 (7.65)
	Height	H1	167 (6.57)	167 (6.57)	167 (6.57)	167 (6.57)	110 (4.33)	116 (4.57)	129 (5.08)	148 (5.83)	165 (6.50)	175 (6.89)	201 (7.91)	230 (9.06)	244 (9.62)	294 (11.59)
	Height	H3	-	-	-	-	-	-	-	-	-	-	-	-	235 (9.26)	285 (11.22)
Remote Sensor	Maximum Height	Hr	284 (11.18)	284 (11.18)	284 (11.18)	284 (11.18)	227 (8.94)	233 (9.17)	246 (9.69)	265 (10.43)	282 (11.10)	292 (11.50)	318 (12.52)	347 (13.66)	412 (16.21)	
	Approx. Weight, Unit: kg (lb) (*2)		2.7 (6.0)	2.7 (6.0)	2.7 (6.0)	2.7 (6.0)	2.2 (4.9)	2.2 (4.9)	2.6 (5.7)	3.2 (7.1)	3.9 (8.6)	4.6 (10.1)	6.3 (13.9)	10.5 (23.2)	15 (33.1)	22 (48.6)
Integral Flowmeter	Maximum Height	Hi	329 (12.95)	329 (12.95)	329 (12.95)	329 (12.95)	272 (10.71)	278 (10.94)	291 (11.46)	310 (12.20)	327 (12.87)	337 (13.27)	363 (14.29)	392 (15.43)	456 (17.97)	
	Approx. Weight, Unit: kg (lb)		5.3 (11.7)	5.3 (11.7)	5.3 (11.7)	5.3 (11.7)	4.8 (10.6)	4.9 (10.8)	5.1 (11.2)	5.7 (12.6)	6.4 (14.1)	7.2 (15.9)	8.8 (19.4)	13.1 (28.9)	17 (37.5)	25 (55.2)
Gaskets (BSC, BSF) (*1)			+6 (+0.24)	+6 (+0.24)	+6 (+0.24)	+6 (+0.24)	+6 (+0.24)	+6 (+0.24)	+6 (+0.24)	+6 (+0.24)	+6 (+0.24)	+6 (+0.24)	+6 (+0.24)	+6 (+0.24)	+6 (+0.24)	
Grounding rings thin type (GRL, GRH, GRV) (*1)			+2 (+0.08)	+2 (+0.08)	+2 (+0.08)	+2 (+0.08)	+2 (+0.08)	+2 (+0.08)	+2 (+0.08)	+2 (+0.08)	+2 (+0.08)	+2 (+0.08)	+2 (+0.08)	+2 (+0.08)	+2 (+0.08)	
Grounding rings thin type (GRL, GRH, GRV) and gaskets (BSC, BSF) (*1)			+8 (+0.31)	+8 (+0.31)	+8 (+0.31)	+8 (+0.31)	+8 (+0.31)	+8 (+0.31)	+8 (+0.31)	+8 (+0.31)	+8 (+0.31)	+8 (+0.31)	+8 (+0.31)	+8 (+0.31)	+8 (+0.31)	
Grounding rings thick type (GRN, GRJ, GRW) with gaskets (GA, GC, GD) (*1)			+8 (+0.31)	+8 (+0.31)	+8 (+0.31)	+8 (+0.31)	+10 (+0.39)	+10 (+0.39)	+10 (+0.39)	+10 (+0.39)	+10 (+0.39)	+10 (+0.39)	+10 (+0.39)	+10 (+0.39)	+12 (+0.47)	
Grounding rings thick type (GRN, GRJ, GRW) with gaskets (GA, GC, GD) and gaskets (BSC, BSF) (*1)			+14 (+0.55)	+14 (+0.55)	+14 (+0.55)	+14 (+0.55)	+16 (+0.63)	+16 (+0.63)	+16 (+0.63)	+16 (+0.63)	+16 (+0.63)	+16 (+0.63)	+16 (+0.63)	+16 (+0.63)	+18 (+0.71)	
Grounding rings electrode type (GRP, GRT) (*1)			+28 (+1.10)	+28 (+1.10)	+28 (+1.10)	+28 (+1.10)	+28 (+1.10)	+28 (+1.10)	+28 (+1.10)	+28 (+1.10)	+28 (+1.10)	+28 (+1.10)	+28 (+1.10)	+28 (+1.10)	+32 (+1.26)	
Grounding rings electrode type (GRP, GRT) and gaskets (BSC, BSF) (*1)			+34 (+1.34)	+34 (+1.34)	+34 (+1.34)	+34 (+1.34)	+34 (+1.34)	+34 (+1.34)	+34 (+1.34)	+34 (+1.34)	+34 (+1.34)	+34 (+1.34)	+34 (+1.34)	+34 (+1.34)	+38 (+1.50)	
Grounding rings electrode type (GRP, GRT) with gaskets (GA, GC, GD) (*1)			+30 (+1.18)	+30 (+1.18)	+30 (+1.18)	+30 (+1.18)	+32 (+1.26)	+32 (+1.26)	+32 (+1.26)	+32 (+1.26)	+32 (+1.26)	+32 (+1.26)	+32 (+1.26)	+32 (+1.26)	+38 (+1.50)	
Grounding rings electrode type (GRP, GRT) with gaskets (GA, GC, GD) and gaskets (BSC, BSF) (*1)			+36 (+1.42)	+36 (+1.42)	+36 (+1.42)	+36 (+1.42)	+38 (+1.50)	+38 (+1.50)	+38 (+1.50)	+38 (+1.50)	+38 (+1.50)	+38 (+1.50)	+38 (+1.50)	+38 (+1.50)	+44 (+1.73)	

\*1: Add the value above (which is the total of both ends) to the lay length "L" when selecting optional grounding rings with/without gaskets.

\*2: When submersible use or optional code DHC is selected, waterproof glands with union joints and cables are attached. When the cable length is 30-meters, add 9.5 kg (20.9 lb) to the weight in the table.

● Flange (PFA Lining, excluding High Pressure Type)

Unit: mm (approx. in.)

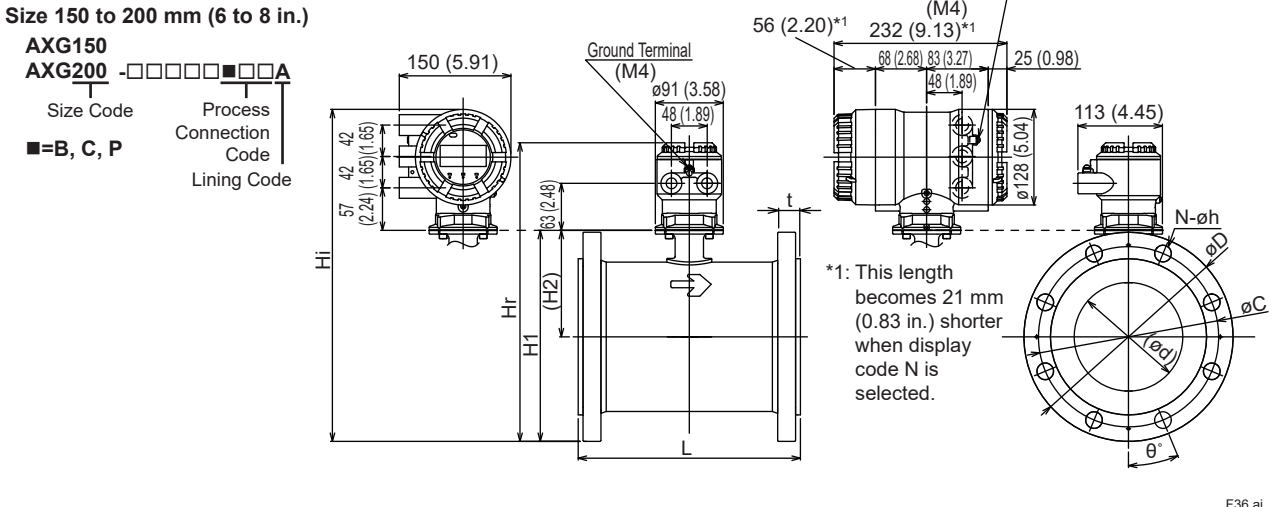
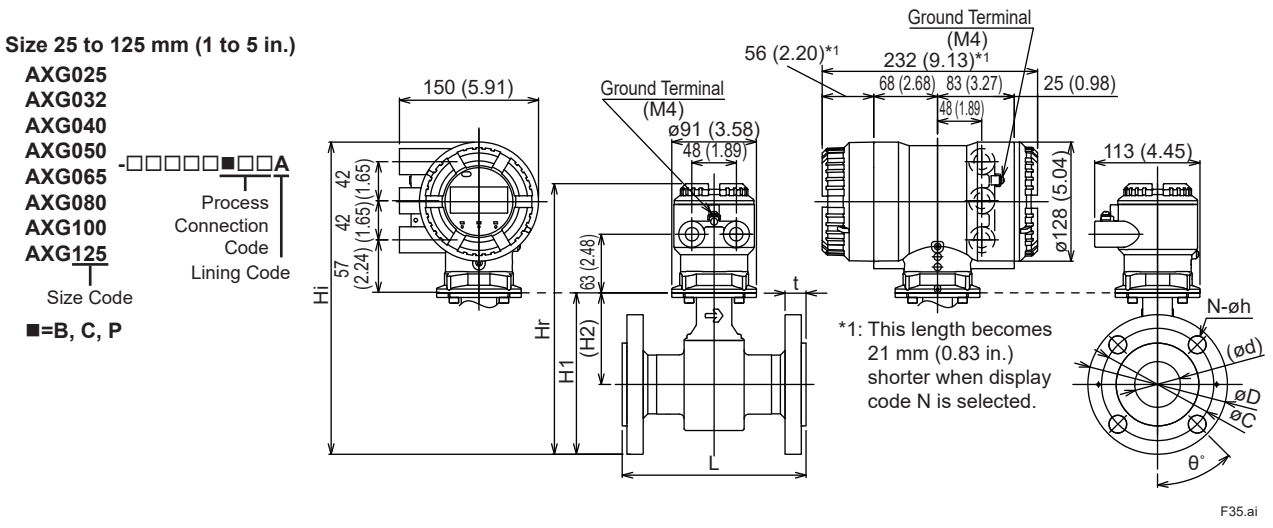
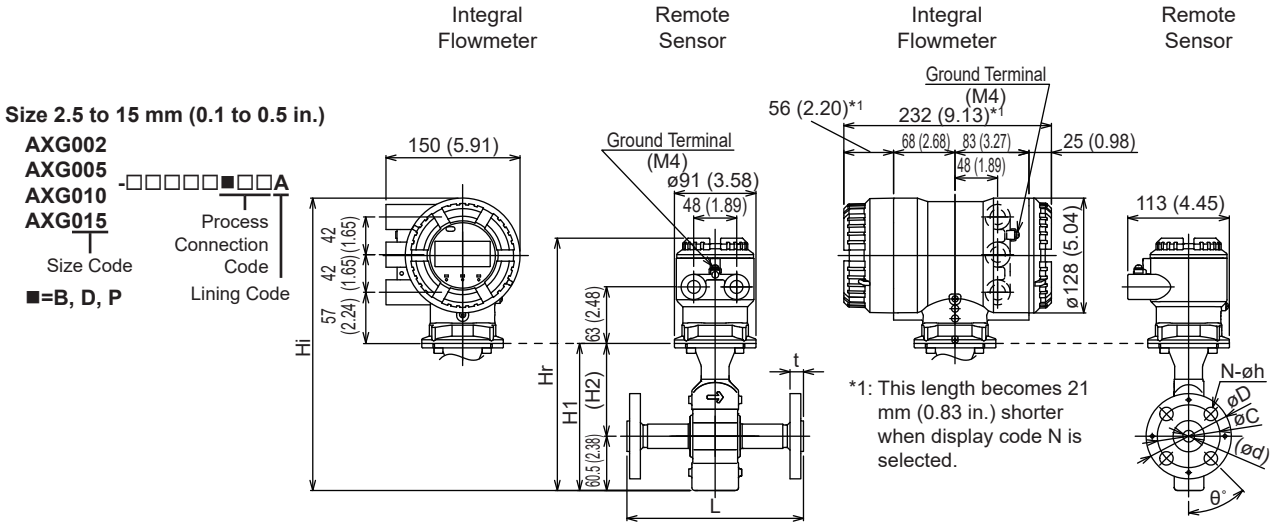

Unit: mm (approx. in.)

Size 250 to 400 mm (10 to 16 in.)

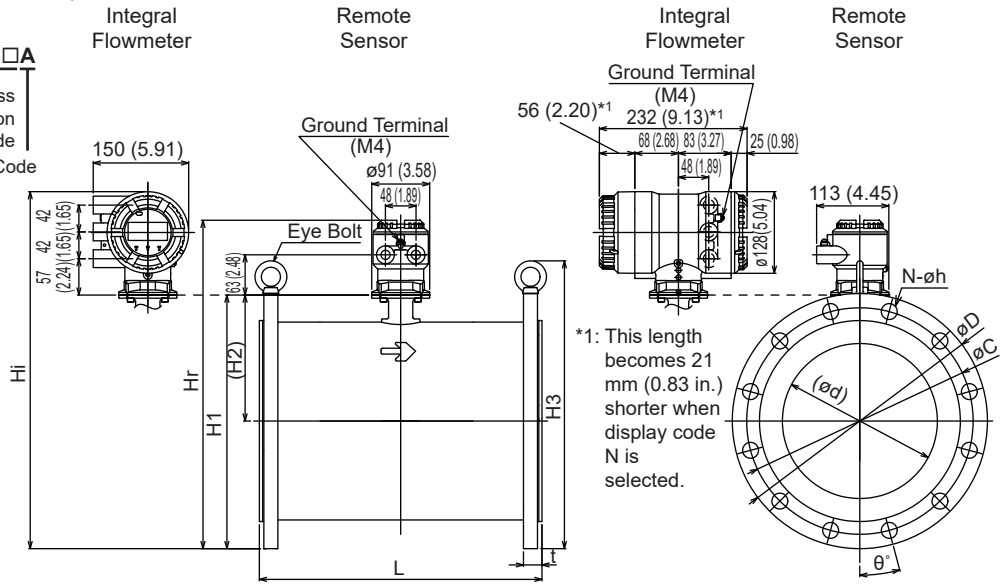
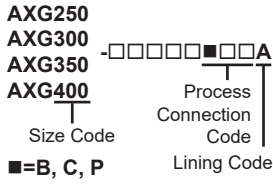

F37.ai

Size 500 mm (20 in.)

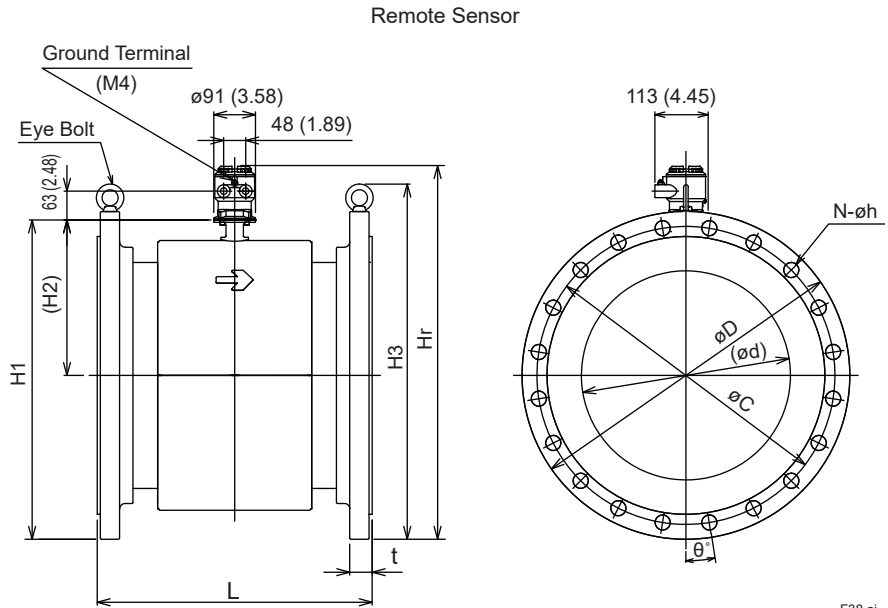
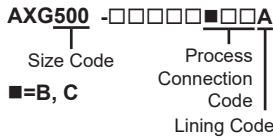

F38.ai

○ Flange, ASME Class 150

Unit: mm (approx. in.)

Model	Process Connection Code	BA1																			
		PA1										CA1									
		002	005	010	015	025	032	040	050	065	080	100	125	150	200	250	300	350	400	500	-
Size	2.5 (0.1)	5 (0.2)	10 (0.4)	15 (0.5)	25 (1)	32 (1.25)	40 (1.5)	50 (2)	65 (2.5)	80 (3)	100 (4)	125 (5)	150 (6)	200 (8)	250 (10)	300 (12)	350 (14)	400 (16)	500 (20)	-	
Lining Code	A	A	A	A	A	A	A	A	A	A	A	A	A	A	A	A	A	A	A	A	
Remote Sensor	Lay Length (*1) (°3)	L	148 (5.83)	148 (5.83)	148 (5.83)	198 (7.80)	198 (7.78)	198 (7.78)	198 (7.78)	198 (7.78)	198 (7.78)	198 (7.78)	248 (9.74)	248 (9.74)	298 (11.71)	348 (13.68)	446 (17.54)	496 (19.51)	546 (21.48)	600 (23.62)	
	Flange Outer Diameter	øD	90 (3.54)	90 (3.54)	90 (3.54)	110 (4.33)	115 (4.53)	125 (4.92)	150 (5.91)	180 (7.09)	190 (7.48)	230 (9.06)	255 (10.04)	280 (11.02)	345 (13.58)	405 (15.94)	485 (19.09)	535 (21.06)	595 (23.43)	700 (27.56)	
	Flange Thickness (incl. lining flare)	t	19.2 (0.76)	19.2 (0.76)	19.2 (0.76)	16.2 (0.64)	18.7 (0.74)	19.3 (0.76)	20.9 (0.82)	22.5 (0.89)	25.7 (1.01)	27.3 (1.07)	27.3 (1.07)	30.4 (1.20)	33.5 (1.32)	35.6 (1.40)	37.2 (1.46)	40.9 (1.61)	42.5 (1.67)	48.6 (1.91)	
	Lining Inner Diameter	ød	2 (0.09)	5 (0.19)	8 (0.30)	13 (0.51)	13 (0.93)	24 (1.13)	29 (1.44)	37 (1.94)	49 (2.40)	61 (2.87)	73 (3.82)	97 (4.76)	121 (5.72)	145 (7.65)	194 (9.55)	243 (11.51)	292 (12.73)	323 (14.70)	459 (18.07)
	Bolt Circle Diameter	øC	60.3 (2.37)	60.3 (2.37)	60.3 (2.37)	60.3 (2.37)	79.4 (3.13)	88.9 (3.50)	98.4 (3.87)	120.7 (4.75)	139.7 (5.50)	152.4 (6.00)	190.5 (7.50)	215.9 (8.50)	241.3 (9.50)	298.5 (11.75)	362.0 (14.25)	431.8 (17.00)	476.3 (18.75)	539.8 (21.25)	635.0 (25.00)
	Bolt Hole Interval	θ°	45	45	45	45	45	45	45	45	45	45	22.5	22.5	22.5	22.5	15	15	15	11.25	9
	Bolt Hole Diameter	øh	15.9 (0.63)	15.9 (0.63)	15.9 (0.63)	15.9 (0.63)	15.9 (0.63)	15.9 (0.63)	15.9 (0.63)	15.9 (0.75)	19.1 (0.75)	19.1 (0.75)	19.1 (0.75)	22.2 (0.87)	22.3 (0.88)	22.3 (0.88)	25.4 (1.00)	25.4 (1.00)	28.6 (1.13)	28.6 (1.13)	31.8 (1.25)
	Number of Bolt Holes	N	4	4	4	4	4	4	4	4	4	4	8	8	8	8	12	12	12	16	20
	Height	H1	164 (6.46)	164 (6.46)	164 (6.46)	164 (6.46)	135 (5.31)	144 (5.67)	149 (5.87)	174 (6.85)	198 (7.80)	209 (8.23)	239 (9.41)	266 (10.47)	283 (11.12)	340 (13.39)	401 (15.78)	465 (18.32)	512 (20.14)	569 (22.41)	689 (27.12)
	Height	H2	104 (4.09)	104 (4.09)	104 (4.09)	104 (4.09)	80 (3.15)	86 (3.39)	86 (3.39)	99 (3.90)	108 (4.25)	114 (4.49)	124 (4.88)	138 (5.43)	143 (5.61)	168 (6.60)	198 (7.81)	223 (8.77)	244 (9.61)	272 (10.70)	339 (13.34)
Height	H3	-	-	-	-	-	-	-	-	-	-	-	-	-	-	456 (17.95)	536 (21.10)	595 (23.43)	655 (25.79)	760 (29.92)	
Remote Sensor	Maximum Height	Hr	281 (11.06)	281 (11.06)	281 (11.06)	252 (9.92)	261 (10.28)	266 (10.47)	291 (11.46)	315 (12.40)	326 (12.83)	356 (14.02)	383 (15.08)	400 (15.74)	457 (18.01)	518 (20.40)	583 (22.94)	629 (24.76)	687 (27.03)	806 (31.74)	
	Approx. Weight, Unit: kg (lb) (*2)		3.6 (7.9)	3.6 (7.9)	3.6 (7.9)	3.8 (8.4)	4.2 (9.3)	4.8 (10.6)	5.5 (12.1)	7.4 (16.3)	10.8 (23.8)	13.0 (28.7)	18.2 (40.1)	22.8 (50.3)	31 (68.4)	50 (110.4)	79 (174.4)	109 (240.6)	136 (300.2)	173 (381.9)	233 (514.4)
Integral Flowmeter	Maximum Height	Hi	326 (12.83)	326 (12.83)	326 (12.83)	326 (12.83)	297 (11.69)	306 (12.05)	311 (12.24)	336 (13.23)	360 (14.17)	371 (14.61)	401 (15.79)	428 (16.85)	445 (17.50)	502 (19.77)	563 (22.16)	627 (24.69)	674 (26.52)	731 (28.79)	-
	Approx. Weight, Unit: kg (lb)		6.1 (13.5)	6.1 (13.5)	6.1 (13.5)	6.4 (14.1)	6.7 (14.8)	7.3 (16.1)	8.0 (17.6)	9.9 (21.8)	13.7 (30.2)	15.5 (34.2)	20.7 (45.6)	25.4 (56.0)	34 (75.1)	52 (114.8)	82 (181.0)	111 (245.0)	138 (304.6)	175 (386.3)	-
Grounding rings thin type (GRL, GRH, GRV) (*1)			+2 (+0.08)	+2 (+0.08)	+2 (+0.08)	+2 (+0.08)	+2 (+0.08)	+2 (+0.08)	+2 (+0.08)	+2 (+0.08)	+2 (+0.08)	+2 (+0.08)	+2 (+0.08)	+2 (+0.08)	+2 (+0.08)	+2 (+0.08)	+2 (+0.08)	+2 (+0.08)	+2 (+0.08)	+2 (+0.08)	-
Grounding rings thick type (GRN, GRJ, GRW) (*1)			+6 (+0.24)	+6 (+0.24)	+6 (+0.24)	+6 (+0.24)	+6 (+0.24)	+6 (+0.24)	+6 (+0.24)	+6 (+0.24)	+6 (+0.24)	+6 (+0.24)	+6 (+0.24)	+6 (+0.24)	+6 (+0.24)	+6 (+0.24)	+6 (+0.24)	+6 (+0.24)	+6 (+0.24)	+6 (+0.24)	+8 (+0.31)
Grounding rings thick type (GRN, GRJ, GRW) with gaskets (GA, GC, GD) (*1)			+10 (+0.39)	+10 (+0.39)	+10 (+0.39)	+10 (+0.39)	+10 (+0.39)	+10 (+0.39)	+10 (+0.39)	+10 (+0.39)	+10 (+0.39)	+10 (+0.39)	+10 (+0.39)	+10 (+0.39)	+10 (+0.39)	+12 (+0.47)	+12 (+0.47)	-	-	-	-
Grounding rings electrode type (GRP, GRT) (*1)			+28 (+1.10)	+28 (+1.10)	+28 (+1.10)	+28 (+1.10)	+28 (+1.14)	+29 (+1.14)	+29 (+1.14)	+29 (+1.14)	+29 (+1.14)	+29 (+1.14)	+29 (+1.14)	+29 (+1.14)	+29 (+1.34)	+29 (+1.34)	-	-	-	-	-
Grounding rings electrode type (GRP, GRT) with gaskets (GA, GC, GD) (*1)			+32 (+1.26)	+32 (+1.26)	+32 (+1.26)	+32 (+1.26)	+33 (+1.30)	+33 (+1.30)	+33 (+1.30)	+33 (+1.30)	+33 (+1.30)	+33 (+1.30)	+33 (+1.30)	+33 (+1.30)	+33 (+1.30)	+40 (+1.57)	+40 (+1.57)	-	-	-	-

- \*1: Add the value above (which is the total of both ends) to the lay length "L" when selecting optional grounding rings with/without gaskets.
- \*2: When submersible use or optional code DHC is selected, waterproof glands with union joints and cables are attached. When the cable length is 30-meters, add 9.5 kg (20.9 lb) to the weight in the table.
- \*3: The tolerance of the lay length "L" is as follows.
  - Size 2.5 to 200 mm (0.1 to 8 in.): 0/-3 mm
  - Size 250 to 400 mm (10 to 16 in.): 0/-5 mm

○ Flange, ASME Class 300

Unit: mm (approx. in.)

Model	Process Connection Code	BA2																	
		PA2								CA2									
		Size Code		002	005	010	015	025	032	040	050	065	080	100	125	150	200	250	300
		Size		2.5 (0.1)	5 (0.2)	10 (0.4)	15 (0.5)	25 (1)	32 (1.25)	40 (1.5)	50 (2)	65 (2.5)	80 (3)	100 (4)	125 (5)	150 (6)	200 (8)	250 (10)	300 (12)
Lining Code		A	A	A	A	A	A	A	A	A	A	A	A	A	A	A	A		
Remote Sensor	Lay Length (*1) (*3)	L	148 (5.83)	148 (5.83)	148 (5.83)	198 (7.80)	198 (7.78)	198 (7.78)	198 (7.78)	198 (7.78)	198 (7.78)	248 (9.74)	248 (9.74)	298 (11.71)	348 (13.68)	446 (17.54)	496 (19.51)		
	Flange Outer Diameter	øD	95 (3.74)	95 (3.74)	95 (3.74)	95 (3.74)	125 (4.92)	135 (5.31)	155 (6.10)	165 (6.50)	190 (7.48)	210 (8.27)	255 (10.04)	280 (11.02)	320 (12.60)	380 (14.96)	445 (17.52)	520 (20.47)	
	Flange Thickness (incl. lining flare)	t	20.3 (0.80)	20.3 (0.80)	20.3 (0.80)	17.3 (0.68)	21.9 (0.86)	22.5 (0.89)	24.1 (0.95)	25.7 (1.01)	28.9 (1.14)	32.0 (1.26)	35.2 (1.39)	38.4 (1.51)	41.5 (1.63)	46.2 (1.82)	53.1 (2.09)	56.3 (2.22)	
	Lining Inner Diameter	ød	2 (0.09)	5 (0.19)	8 (0.30)	13 (0.51)	24 (0.93)	29 (1.13)	37 (1.44)	49 (1.94)	61 (2.40)	73 (2.87)	97 (3.82)	121 (4.76)	145 (5.72)	194 (7.65)	243 (9.55)	292 (11.51)	
	Bolt Circle Diameter	øC	66.7 (2.63)	66.7 (2.63)	66.7 (2.63)	66.7 (2.63)	88.9 (3.50)	98.4 (3.87)	114.3 (4.50)	127.0 (5.00)	149.2 (5.87)	168.3 (6.63)	200.0 (7.87)	235.0 (9.25)	269.9 (10.63)	330.2 (13.00)	387.4 (15.25)	450.8 (17.75)	
	Bolt Hole Interval	θ°	45	45	45	45	45	45	45	22.5	22.5	22.5	22.5	22.5	15	15	11.25	11.25	
	Bolt Hole Diameter	øh	15.9 (0.63)	15.9 (0.63)	15.9 (0.63)	15.9 (0.63)	19.1 (0.75)	19.1 (0.75)	22.2 (0.87)	22.2 (0.87)	22.2 (0.87)	22.2 (0.87)	22.2 (0.87)	22.2 (0.87)	22.3 (0.88)	25.4 (1.00)	28.6 (1.13)	31.8 (1.25)	
	Number of Bolt Holes	N	4	4	4	4	4	4	4	8	8	8	8	8	12	12	16	16	
	Height	H1	164 (6.46)	164 (6.46)	164 (6.46)	164 (6.46)	143 (5.63)	154 (6.06)	164 (6.46)	182 (7.17)	203 (7.99)	219 (8.62)	252 (9.92)	278 (10.94)	303 (11.91)	358 (14.08)	421 (16.57)	483 (19.01)	
	Height	H2	104 (4.09)	104 (4.09)	104 (4.09)	104 (4.09)	80 (3.15)	86 (3.39)	99 (3.93)	108 (4.25)	114 (4.49)	124 (4.88)	138 (5.43)	143 (5.61)	168 (6.60)	198 (7.81)	223 (8.77)	292 (11.51)	
Height	H3	-	-	-	-	-	-	-	-	-	-	-	-	-	-	496 (19.53)	571 (22.48)		
Remote Sensor	Maximum Height	Hr	281 (11.06)	281 (11.06)	281 (11.06)	281 (11.06)	260 (10.24)	271 (10.67)	281 (11.06)	299 (11.77)	320 (12.60)	336 (13.23)	369 (14.53)	395 (15.55)	420 (16.53)	475 (18.70)	538 (21.19)	600 (23.62)	
	Approx. Weight, Unit: kg (lb) (*2)		3.9 (8.6)	3.9 (8.6)	3.9 (8.6)	4.0 (8.8)	5.2 (11.5)	6.2 (13.7)	8.0 (17.6)	9.3 (20.5)	13.2 (29.1)	17.2 (37.9)	26.7 (58.9)	35.5 (78.3)	47 (103.8)	71 (156.7)	112 (247.2)	152 (335.5)	
Integral Flowmeter	Maximum Height	Hi	326 (12.83)	326 (12.83)	326 (12.83)	326 (12.83)	305 (12.01)	316 (12.44)	326 (12.83)	344 (13.54)	365 (14.37)	381 (15.00)	414 (16.30)	440 (17.32)	465 (18.29)	520 (20.46)	583 (22.95)	645 (25.38)	
	Approx. Weight, Unit: kg (lb)		6.5 (14.3)	6.5 (14.3)	6.5 (14.3)	6.6 (14.6)	7.8 (17.2)	8.8 (19.4)	10.5 (23.2)	11.8 (26.0)	15.7 (34.6)	19.7 (43.4)	29.2 (64.4)	38.0 (83.8)	50 (110.4)	74 (163.4)	114 (251.7)	155 (342.2)	
Grounding rings thin type (GRL, GRH, GRV) (*1)			+2 (+0.08)	+2 (+0.08)	+2 (+0.08)	+2 (+0.08)	+2 (+0.08)	+2 (+0.08)	+2 (+0.08)	+2 (+0.08)	+2 (+0.08)	+2 (+0.08)	+2 (+0.08)	+2 (+0.08)	+2 (+0.08)	+2 (+0.08)	+4 (+0.16)	+4 (+0.16)	
Grounding rings thick type (GRN, GRJ, GRW) (*1)			+6 (+0.24)	+6 (+0.24)	+6 (+0.24)	+6 (+0.24)	+6 (+0.24)	+6 (+0.24)	+6 (+0.24)	+6 (+0.24)	+6 (+0.24)	+6 (+0.24)	+6 (+0.24)	+6 (+0.24)	+6 (+0.24)	+6 (+0.24)	+6 (+0.24)	+6 (+0.24)	
Grounding rings thick type (GRN, GRJ, GRW) with gaskets (GA, GC, GD) (*1)			+10 (+0.39)	+10 (+0.39)	+10 (+0.39)	+10 (+0.39)	+10 (+0.39)	+10 (+0.39)	+10 (+0.39)	+10 (+0.39)	+10 (+0.39)	+10 (+0.39)	+10 (+0.39)	+10 (+0.39)	+12 (+0.47)	+12 (+0.47)	-	-	
Grounding rings electrode type (GRP, GRT) (*1)			+28 (+1.10)	+28 (+1.10)	+28 (+1.10)	+28 (+1.10)	+29 (+1.14)	+29 (+1.14)	+29 (+1.14)	+29 (+1.14)	+29 (+1.14)	+29 (+1.14)	+29 (+1.14)	+29 (+1.14)	+34 (+1.34)	+34 (+1.34)	-	-	
Grounding rings electrode type (GRP, GRT) with gaskets (GA, GC, GD) (*1)			+32 (+1.26)	+32 (+1.26)	+32 (+1.26)	+32 (+1.26)	+33 (+1.30)	+33 (+1.30)	+33 (+1.30)	+33 (+1.30)	+33 (+1.30)	+33 (+1.30)	+33 (+1.30)	+33 (+1.30)	+40 (+1.57)	+40 (+1.57)	-	-	

- \*1: Add the value above (which is the total of both ends) to the lay length "L" when selecting optional grounding rings with/without gaskets.
- \*2: When submersible use or optional code DHC is selected, waterproof glands with union joints and cables are attached. When the cable length is 30-meters, add 9.5 kg (20.9 lb) to the weight in the table.
- \*3: The tolerance of the lay length "L" is as follows.
  - Size 2.5 to 200 mm (0.1 to 8 in.): 0/-3 mm
  - Size 250 to 400 mm (10 to 16 in.): 0/-5 mm

○ Flange, EN PN16, EN PN40

Unit: mm (approx. in.)

Model	Process Connection Code	DE4			BE4								BE2									
		-	-	-	-	-	-	-	-	-	-	-	-	-	-	-	-	-	-			
		PE4			PE4			CE4		PE2			PE2									
Size Code	002	005	010	002	005	010	015	025	032	040	050	065	080	100	125	150	200	250	300	500		
Size	2.5	5	10	2.5	5	10	15	25	32	40	50	65	80	100	125	150	200	250	300	500		
Lining Code	A	A	A	A	A	A	A	A	A	A	A	A	A	A	A	A	A	A	A	A		
Remote Sensor	Lay Length (*1) (*3) L	148 (5.83)	148 (5.83)	148 (5.83)	148 (5.83)	148 (5.83)	148 (5.83)	198 (7.80)	198 (7.78)	198 (7.78)	198 (7.78)	198 (7.78)	198 (7.78)	248 (9.74)	248 (9.74)	298 (11.71)	348 (13.68)	446 (17.54)	496 (19.51)	600 (23.62)		
	Flange Outer Diameter øD	90 (3.54)	90 (3.54)	90 (3.54)	95 (3.74)	95 (3.74)	95 (3.74)	95 (3.74)	115 (4.53)	140 (5.51)	150 (5.91)	165 (6.50)	185 (7.28)	200 (7.87)	220 (8.66)	250 (9.84)	285 (11.22)	340 (13.39)	405 (15.94)	460 (18.11)	715 (28.15)	
	Flange Thickness (incl. lining flare) t	20.0 (0.79)	20.0 (0.79)	20.0 (0.79)	20.0 (0.79)	20.0 (0.79)	20.0 (0.79)	19.0 (0.75)	22.0 (0.87)	21.0 (0.83)	21.0 (0.83)	23.0 (0.91)	21.0 (0.83)	23.0 (0.91)	23.0 (0.91)	25.0 (0.98)	25.5 (1.00)	27.5 (1.08)	31.0 (1.18)	31.0 (1.22)	49.3 (1.94)	
	Lining Inner Diameter ød	2 (0.09)	5 (0.19)	8 (0.30)	2 (0.09)	5 (0.19)	8 (0.30)	8 (0.31)	13 (0.51)	24 (0.93)	29 (1.13)	37 (1.44)	49 (1.94)	61 (2.40)	73 (2.87)	97 (3.82)	121 (4.76)	145 (5.72)	194 (7.65)	243 (9.55)	292 (11.51)	459 (18.07)
	Bolt Circle Diameter øC	60 (2.36)	60 (2.36)	60 (2.36)	65 (2.56)	65 (2.56)	65 (2.56)	65 (2.56)	85 (3.35)	100 (3.94)	110 (4.33)	125 (4.92)	145 (5.71)	160 (6.30)	180 (7.09)	210 (8.27)	240 (9.45)	295 (11.61)	355 (13.98)	410 (16.14)	650 (25.59)	
	Bolt Hole Interval ø°	45	45	45	45	45	45	45	45	45	45	45	22.5	22.5	22.5	22.5	22.5	15	15	15	9	
	Bolt Hole Diameter øh	14 (0.55)	14 (0.55)	14 (0.55)	14 (0.55)	14 (0.55)	14 (0.55)	14 (0.55)	14 (0.55)	18 (0.71)	18 (0.71)	18 (0.71)	18 (0.71)	18 (0.71)	18 (0.71)	18 (0.71)	18 (0.71)	18 (0.71)	22 (0.87)	26 (1.02)	33 (1.30)	
	Number of Bolt Holes N	4	4	4	4	4	4	4	4	4	4	4	8	8	8	8	8	12	12	12	20	
	Height H1	164 (6.46)	164 (6.46)	164 (6.46)	164 (6.46)	164 (6.46)	164 (6.46)	164 (6.46)	138 (5.43)	156 (6.14)	161 (6.34)	182 (7.17)	201 (7.91)	214 (8.43)	234 (9.21)	263 (10.35)	285 (11.22)	338 (13.29)	401 (15.78)	453 (17.82)	696 (27.42)	
	Height H2	104 (4.09)	104 (4.09)	104 (4.09)	104 (4.09)	104 (4.09)	104 (4.09)	104 (4.09)	80 (3.15)	86 (3.39)	86 (3.39)	99 (3.90)	108 (4.25)	114 (4.49)	124 (4.88)	138 (5.43)	143 (5.61)	168 (6.60)	198 (7.81)	223 (8.77)	339 (13.34)	
Height H3	-	-	-	-	-	-	-	-	-	-	-	-	-	-	-	-	-	456 (17.95)	511 (20.12)	786 (30.94)		
Remote Sensor	Maximum Height Hr	281 (11.06)	281 (11.06)	281 (11.06)	281 (11.06)	281 (11.06)	281 (11.06)	281 (11.06)	255 (10.04)	273 (10.75)	278 (10.94)	299 (11.77)	318 (12.52)	331 (13.03)	351 (13.82)	380 (14.96)	402 (15.84)	455 (17.91)	518 (20.40)	814 (32.04)		
	Approx. Weight, Unit: kg (lb) (*2)	3.9 (8.6)	3.9 (8.6)	3.9 (8.6)	4.1 (9.0)	4.1 (9.0)	4.1 (9.0)	4.2 (9.3)	4.8 (10.6)	6.4 (14.1)	7.1 (15.7)	8.9 (19.6)	9.9 (21.8)	12.4 (27.3)	15.0 (33.1)	20.7 (45.6)	29 (64.0)	44 (97.1)	73 (161.2)	91 (200.9)	247 (545.3)	
Integral Flowmeter	Maximum Height Hi	326 (12.83)	326 (12.83)	326 (12.83)	326 (12.83)	326 (12.83)	326 (12.83)	326 (12.83)	300 (11.81)	318 (12.52)	323 (12.72)	344 (13.54)	363 (14.29)	376 (14.80)	396 (15.59)	425 (16.73)	447 (17.60)	500 (19.67)	563 (22.16)	615 (24.20)	-	
	Approx. Weight, Unit: kg (lb)	6.5 (14.3)	6.5 (14.3)	6.5 (14.3)	6.7 (14.8)	6.7 (14.8)	6.7 (14.8)	6.8 (15.0)	7.4 (16.3)	9.0 (19.8)	9.6 (21.2)	11.4 (25.1)	12.4 (27.3)	15.0 (33.1)	17.6 (38.8)	23.3 (51.4)	31 (68.4)	46 (101.6)	75 (165.6)	93 (205.3)	-	
Grounding rings thin type (GRL, GRH, GRV) (*1)		+2 (+0.08)	+2 (+0.08)	+2 (+0.08)	+2 (+0.08)	+2 (+0.08)	+2 (+0.08)	+2 (+0.08)	+2 (+0.08)	+2 (+0.08)	+2 (+0.08)	+2 (+0.08)	+2 (+0.08)	+2 (+0.08)	+2 (+0.08)	+2 (+0.08)	+2 (+0.08)	+2 (+0.08)	+4 (+0.16)	+4 (+0.16)	-	
Grounding rings thick type (GRN, GRJ, GRW) (*1)		+6 (+0.24)	+6 (+0.24)	+6 (+0.24)	+6 (+0.24)	+6 (+0.24)	+6 (+0.24)	+6 (+0.24)	+6 (+0.24)	+6 (+0.24)	+6 (+0.24)	+6 (+0.24)	+6 (+0.24)	+6 (+0.24)	+6 (+0.24)	+6 (+0.24)	+6 (+0.24)	+6 (+0.24)	+6 (+0.24)	+6 (+0.24)	+8 (+0.31)	
Grounding rings thick type (GRN, GRJ, GRW) with gaskets (GA, GC, GD) (*1)		+10 (+0.39)	+10 (+0.39)	+10 (+0.39)	+10 (+0.39)	+10 (+0.39)	+10 (+0.39)	+10 (+0.39)	+10 (+0.39)	+10 (+0.39)	+10 (+0.39)	+10 (+0.39)	+10 (+0.39)	+10 (+0.39)	+10 (+0.39)	+10 (+0.39)	+10 (+0.39)	+10 (+0.39)	+12 (+0.47)	+12 (+0.47)	-	
Grounding rings electrode type (GRP, GRT) (*1)		+28 (+1.10)	+28 (+1.10)	+28 (+1.10)	+28 (+1.10)	+28 (+1.10)	+28 (+1.10)	+28 (+1.10)	+29 (+1.14)	+29 (+1.14)	+29 (+1.14)	+29 (+1.14)	+29 (+1.14)	+29 (+1.14)	+29 (+1.14)	+29 (+1.14)	+29 (+1.14)	+34 (+1.34)	+34 (+1.34)	-	-	
Grounding rings electrode type (GRP, GRT) with gaskets (GA, GC, GD) (*1)		+32 (+1.26)	+32 (+1.26)	+32 (+1.26)	+32 (+1.26)	+32 (+1.26)	+32 (+1.26)	+32 (+1.26)	+33 (+1.30)	+33 (+1.30)	+33 (+1.30)	+33 (+1.30)	+33 (+1.30)	+33 (+1.30)	+33 (+1.30)	+33 (+1.30)	+33 (+1.30)	+40 (+1.57)	+40 (+1.57)	-	-	

- \*1: Add the value above (which is the total of both ends) to the lay length "L" when selecting optional grounding rings with/without gaskets.
- \*2: When submersible use or optional code DHC is selected, waterproof glands with union joints and cables are attached. When the cable length is 30-meters, add 9.5 kg (20.9 lb) to the weight in the table.
- \*3: The tolerance of the lay length "L" is as follows.
  - Size 2.5 to 200 mm (0.1 to 8 in.): 0/-3 mm
  - Size 250 to 400 mm (10 to 16 in.): 0/-5 mm



○ Flange, EN PN10

Unit: mm (approx. in.)

Model	Process Connection Code		BE1					-	
			CE1						
	Size Code		200	250	300	350	400	500	
	Size		200 (8)	250 (10)	300 (12)	350 (14)	400 (16)	500 (20)	
	Lining Code		A	A	A	A	A	A	
Remote Sensor Integral Flowmeter	Lay Length (*1) (*3)	L	348 (13.68)	446 (17.54)	496 (19.51)	546 (21.48)	596 (23.44)	600 (23.62)	
	Flange Outer Diameter	øD	340 (13.39)	395 (15.55)	445 (17.52)	505 (19.88)	565 (22.24)	670 (26.38)	
	Flange Thickness (incl. lining flare)	t	27.5 (1.08)	30.0 (1.18)	29.0 (1.14)	29.5 (1.16)	29.5 (1.16)	33.3 (1.31)	
	Lining Inner Diameter	ød	194 (7.65)	243 (9.55)	292 (11.51)	323 (12.73)	374 (14.70)	459 (18.07)	
	Bolt Circle Diameter	øC	295 (11.61)	350 (13.78)	400 (15.75)	460 (18.11)	515 (20.28)	620 (24.41)	
	Bolt Hole Interval	θ°	22.5	15	15	11.25	11.25	9	
	Bolt Hole Diameter	øh	22 (0.87)	22 (0.87)	22 (0.87)	22 (0.87)	26 (1.02)	26 (1.02)	
	Number of Bolt Holes	N	8	12	12	16	16	20	
	Height	H1	338 (13.29)	396 (15.58)	445 (17.53)	497 (19.55)	554 (21.82)	674 (26.53)	
	Height	H2	168 (6.60)	198 (7.81)	223 (8.77)	244 (9.61)	272 (10.70)	339 (13.34)	
	Height	H3	-	446 (17.56)	496 (19.53)	565 (22.24)	625 (24.61)	730 (28.74)	
	Remote Sensor	Maximum Height	Hr	455 (17.91)	513 (20.20)	563 (22.15)	614 (24.17)	672 (26.44)	791 (31.15)
		Approx. Weight, Unit: kg (lb) (*2)		44 (97.1)	70 (154.5)	84 (185.4)	105 (231.8)	132 (291.4)	189 (417.2)
Integral Flowmeter	Maximum Height	Hi	500 (19.67)	558 (21.96)	607 (23.91)	659 (25.93)	716 (28.20)	-	
	Approx. Weight, Unit: kg (lb)		47 (103.8)	72 (158.9)	87 (192.1)	108 (238.4)	135 (298.0)	-	
Grounding rings thin type (GRL, GRH, GRV) (*1)			+2 (+0.08)	+4 (+0.16)	+4 (+0.16)	+4 (+0.16)	+4 (+0.16)	-	
Grounding rings thick type (GRN, GRJ, GRW) (*1)			+6 (+0.24)	+6 (+0.24)	+6 (+0.24)	+6 (+0.24)	+6 (+0.24)	+8 (+0.31)	
Grounding rings thick type (GRN, GRJ, GRW) with gaskets (GA, GC, GD) (*1)			+12 (+0.47)	-	-	-	-	-	
Grounding rings electrode type (GRP, GRT) (*1)			+34 (+1.34)	-	-	-	-	-	
Grounding rings electrode type (GRP, GRT) with gaskets (GA, GC, GD) (*1)			+40 (+1.57)	-	-	-	-	-	

- \*1: Add the value above (which is the total of both ends) to the lay length "L" when selecting optional grounding rings with/without gaskets.
- \*2: When submersible use or optional code DHC is selected, waterproof glands with union joints and cables are attached. When the cable length is 30-meters, add 9.5 kg (20.9 lb) to the weight in the table.
- \*3: The tolerance of the lay length "L" is as follows.
  - Size 2.5 to 200 mm (0.1 to 8 in.): 0/-3 mm
  - Size 250 to 400 mm (10 to 16 in.): 0/-5 mm

○ Flange, JIS F12

Unit: mm (approx. in.)

Model	Process Connection Code		BG1									
			CG1									
	Size Code		080	100	125	150	200	250	300	350	400	
	Size		80	100	125	150	200	250	300	350	400	
			(3)	(4)	(5)	(6)	(8)	(10)	(12)	(14)	(16)	
	Lining Code		A	A	A	A	A	A	A	A	A	
Remote Sensor Integral Flowmeter	Lay Length (*1) (*3)	L	198 (7.78)	248 (9.74)	248 (9.74)	298 (11.71)	348 (13.68)	446 (17.54)	496 (19.51)	546 (21.48)	596 (23.44)	
	Flange Outer Diameter	øD	211 (8.31)	238 (9.37)	263 (10.35)	290 (11.42)	342 (13.46)	410 (16.14)	464 (18.27)	530 (20.87)	582 (22.91)	
	Flange Thickness (incl. lining flare)	t	23.0 (0.91)	23.0 (0.91)	25.0 (0.98)	26.5 (1.04)	26.5 (1.04)	29.0 (1.14)	28.0 (1.10)	30.5 (1.20)	30.5 (1.20)	
	Lining Inner Diameter	ød	73 (2.87)	97 (3.82)	121 (4.76)	145 (5.72)	194 (7.65)	243 (9.55)	292 (11.51)	323 (12.73)	374 (14.70)	
	Bolt	øC	168 (6.61)	195 (7.68)	220 (8.66)	247 (9.72)	299 (11.77)	360 (14.17)	414 (16.30)	472 (18.58)	524 (20.63)	
	Bolt Hole Interval	ø*	45	45	30	30	22.5	22.5	18	18	15	
	Bolt Hole Diameter	øh	19 (0.75)	19 (0.75)	19 (0.75)	19 (0.75)	19 (0.75)	23 (0.91)	23 (0.91)	25 (0.98)	25 (0.98)	
	Number of Bolt Holes	N	4	4	6	6	8	8	10	10	12	
	Height	H1	220 (8.66)	243 (9.57)	270 (10.63)	288 (11.32)	339 (13.33)	403 (15.88)	455 (17.90)	509 (20.04)	563 (22.16)	
	Height	H2	114 (4.49)	124 (4.88)	138 (5.43)	143 (5.61)	168 (6.60)	198 (7.81)	223 (8.77)	244 (9.61)	272 (10.70)	
	Height	H3	-	-	-	-	-	461 (18.15)	515 (20.28)	581 (22.87)	633 (24.92)	
	Remote Sensor	Maximum Height	Hr	337 (13.27)	360 (14.17)	387 (15.24)	405 (15.94)	456 (17.95)	521 (20.50)	572 (22.52)	626 (24.66)	680 (26.78)
		Approx. Weight, Unit: kg (lb) (*2)		12.8 (28.2)	16.1 (35.5)	21.2 (46.7)	30 (66.2)	43 (94.9)	73 (161.2)	88 (194.3)	114 (251.7)	140 (309.1)
Integral Flowmeter	Maximum Height	Hi	382 (15.04)	405 (15.94)	432 (17.01)	450 (17.70)	501 (19.71)	565 (22.26)	617 (24.28)	671 (26.42)	725 (28.54)	
	Approx. Weight, Unit: kg (lb)		15.3 (33.7)	18.7 (41.2)	23.6 (52.0)	33 (72.9)	46 (101.6)	75 (165.6)	90 (198.7)	116 (256.1)	142 (313.5)	
Grounding rings thin type (GRL, GRH, GRV) (*1)			+2 (+0.08)	+2 (+0.08)	+2 (+0.08)	+2 (+0.08)	+2 (+0.08)	+4 (+0.16)	+4 (+0.16)	+4 (+0.16)	+4 (+0.16)	
Grounding rings thick type (GRN, GRJ, GRW) (*1)			+6 (+0.24)	+6 (+0.24)	+6 (+0.24)	+6 (+0.24)	+6 (+0.24)	+6 (+0.24)	+6 (+0.24)	+6 (+0.24)	+6 (+0.24)	
Grounding rings thick type (GRN, GRJ, GRW) with gaskets (GA, GC, GD) (*1)			+10 (+0.39)	+10 (+0.39)	+10 (+0.39)	+12 (+0.47)	+12 (+0.47)	-	-	-	-	
Grounding rings electrode type (GRP, GRT) (*1)			+29 (+1.14)	+29 (+1.14)	+29 (+1.14)	+34 (+1.34)	+34 (+1.34)	-	-	-	-	
Grounding rings electrode type (GRP, GRT) with gaskets (GA, GC, GD) (*1)			+33 (+1.30)	+33 (+1.30)	+33 (+1.30)	+40 (+1.57)	+40 (+1.57)	-	-	-	-	

- \*1: Add the value above (which is the total of both ends) to the lay length "L" when selecting optional grounding rings with/without gaskets.
- \*2: When submersible use or optional code DHC is selected, waterproof glands with union joints and cables are attached. When the cable length is 30-meters, add 9.5 kg (20.9 lb) to the weight in the table.
- \*3: The tolerance of the lay length "L" is as follows.
  - Size 2.5 to 200 mm (0.1 to 8 in.): 0/-3 mm
  - Size 250 to 400 mm (10 to 16 in.): 0/-5 mm

○ Flange, JIS 10K

Unit: mm (approx. in.)

Model	Process Connection Code	DJ1																BJ1															
		PJ1																CJ1															
		PJ1																PJ1															
		Size Code	002	005	010	002	005	010	015	025	032	040	050	065	080	100	125	150	200	250	300	350	400										
	Size	2.5	5	10	2.5	5	10	15	25	32	40	50	65	80	100	125	150	200	250	300	350	400											
		(0.1)	(0.2)	(0.4)	(0.1)	(0.2)	(0.4)	(0.5)	(1)	(1.25)	(1.5)	(2)	(2.5)	(3)	(4)	(5)	(6)	(8)	(10)	(12)	(14)	(16)											
	Lining Code	A	A	A	A	A	A	A	A	A	A	A	A	A	A	A	A	A	A	A	A	A											
Remote Sensor	Lay Length (*1) (*3)	L	148	148	148	148	148	148	198	198	198	198	198	198	248	248	298	348	446	496	546	596											
			(5.83)	(5.83)	(5.83)	(5.83)	(5.83)	(5.83)	(7.80)	(7.78)	(7.78)	(7.78)	(7.78)	(7.78)	(9.74)	(9.74)	(11.71)	(13.68)	(17.54)	(19.51)	(21.48)	(23.44)											
	Flange Outer Diameter	øD	90	90	90	95	95	95	95	125	135	140	155	175	185	210	250	280	330	400	445	490	560										
			(3.54)	(3.54)	(3.54)	(3.74)	(3.74)	(3.74)	(3.74)	(4.92)	(5.31)	(5.51)	(6.10)	(6.89)	(7.28)	(8.27)	(9.84)	(11.02)	(12.99)	(15.75)	(17.52)	(19.29)	(22.05)										
	Flange Thickness (incl. lining flare)	t	18.0	18.0	18.0	18.0	18.0	18.0	15.0	20.0	21.0	21.0	21.0	23.0	23.0	23.0	25.0	26.5	26.5	29.0	28.0	30.5	32.5										
			(0.71)	(0.71)	(0.71)	(0.71)	(0.71)	(0.71)	(0.59)	(0.79)	(0.83)	(0.83)	(0.83)	(0.91)	(0.91)	(0.91)	(0.98)	(1.04)	(1.04)	(1.14)	(1.10)	(1.20)	(1.28)										
	Lining Inner Diameter	ød	2	5	8	2	5	8	13	24	29	37	49	61	73	97	121	145	194	243	292	323	374										
			(0.09)	(0.19)	(0.30)	(0.09)	(0.19)	(0.30)	(0.51)	(0.93)	(1.13)	(1.44)	(1.94)	(2.40)	(2.87)	(3.82)	(4.76)	(5.72)	(7.65)	(9.55)	(11.51)	(12.73)	(14.70)										
	Bolt Circle Diameter	øC	65	65	65	70	70	70	70	90	100	105	120	140	150	175	210	240	290	355	400	445	510										
			(2.56)	(2.56)	(2.56)	(2.76)	(2.76)	(2.76)	(2.76)	(3.54)	(3.94)	(4.13)	(4.72)	(5.51)	(5.91)	(6.89)	(8.27)	(9.45)	(11.42)	(13.98)	(15.75)	(17.52)	(20.08)										
Integral Flowmeter	Bolt Hole Interval	ø°	45	45	45	45	45	45	45	45	45	45	45	22.5	22.5	22.5	22.5	15	15	11.25	11.25	11.25											
	Bolt Hole Diameter	øh	15	15	15	15	15	15	15	19	19	19	19	19	19	19	23	23	23	25	25	27											
			(0.59)	(0.59)	(0.59)	(0.59)	(0.59)	(0.59)	(0.59)	(0.75)	(0.75)	(0.75)	(0.75)	(0.75)	(0.75)	(0.75)	(0.91)	(0.91)	(0.91)	(0.98)	(0.98)	(1.06)											
	Number of Bolt Holes	N	4	4	4	4	4	4	4	4	4	4	4	4	8	8	8	8	12	12	16	16	16										
	Height	H1	164	164	164	164	164	164	143	154	156	177	196	207	229	263	283	333	398	445	489	552											
		(6.46)	(6.46)	(6.46)	(6.46)	(6.46)	(6.46)	(5.63)	(6.06)	(6.14)	(6.97)	(7.72)	(8.15)	(9.02)	(10.35)	(11.12)	(13.10)	(15.68)	(17.53)	(19.25)	(21.72)												
Height	H2	104	104	104	104	104	104	80	86	86	99	108	114	124	138	143	168	198	223	244	272												
		(4.09)	(4.09)	(4.09)	(4.09)	(4.09)	(4.09)	(3.15)	(3.39)	(3.39)	(3.90)	(4.25)	(4.49)	(4.88)	(5.43)	(6.60)	(7.81)	(8.77)	(9.61)	(10.70)													
Height	H3	-	-	-	-	-	-	-	-	-	-	-	-	-	-	-	-	451	496	550	620												
																		(17.76)	(19.53)	(21.65)	(24.41)												
Remote Sensor	Maximum Height	Hr	281	281	281	281	281	281	260	271	273	294	313	324	346	380	400	450	516	563	606	669											
			(11.06)	(11.06)	(11.06)	(11.06)	(11.06)	(11.06)	(10.24)	(10.67)	(10.75)	(11.57)	(12.32)	(12.76)	(13.62)	(14.96)	(15.74)	(17.71)	(20.30)	(22.15)	(23.87)	(26.34)											
Integral Flowmeter	Approx. Weight, Unit: kg (lb) (*2)		3.6	3.6	3.6	3.7	3.7	3.7	3.8	4.8	5.9	6.1	7.3	9.6	10.2	13.0	19.1	27	39	67	78	95											
			(7.9)	(7.9)	(7.9)	(8.2)	(8.2)	(8.2)	(8.4)	(10.6)	(13.0)	(13.5)	(16.1)	(21.2)	(22.5)	(28.7)	(42.1)	(59.6)	(86.1)	(147.9)	(172.2)	(209.7)	(278.2)										
Integral Flowmeter	Maximum Height	Hi	326	326	326	326	326	326	305	316	318	339	358	369	391	425	445	495	560	607	651	714											
			(12.83)	(12.83)	(12.83)	(12.83)	(12.83)	(12.83)	(12.01)	(12.44)	(12.52)	(13.35)	(14.09)	(14.53)	(15.39)	(16.73)	(17.50)	(19.47)	(22.06)	(23.91)	(25.63)	(28.10)											
	Approx. Weight, Unit: kg (lb)		6.2	6.2	6.2	6.3	6.3	6.3	6.4	7.3	8.4	8.7	9.8	12.1	12.7	15.6	21.6	30	41	69	80	97											
			(13.7)	(13.7)	(13.7)	(13.9)	(13.9)	(13.9)	(14.1)	(16.1)	(18.5)	(19.2)	(21.6)	(26.7)	(28.0)	(34.4)	(47.6)	(66.2)	(90.5)	(152.3)	(176.6)	(214.1)	(284.8)										
Grounding rings thin type (GRL, GRH, GRV) (*1)			+2	+2	+2	+2	+2	+2	+2	+2	+2	+2	+2	+2	+2	+2	+2	+2	+4	+4	+4	+4											
			(+0.08)	(+0.08)	(+0.08)	(+0.08)	(+0.08)	(+0.08)	(+0.08)	(+0.08)	(+0.08)	(+0.08)	(+0.08)	(+0.08)	(+0.08)	(+0.08)	(+0.08)	(+0.08)	(+0.16)	(+0.16)	(+0.16)	(+0.16)											
Grounding rings thick type (GRN, GRJ, GRW) (*1)			+6	+6	+6	+6	+6	+6	+6	+6	+6	+6	+6	+6	+6	+6	+6	+6	+6	+6	+6	+6											
			(+0.24)	(+0.24)	(+0.24)	(+0.24)	(+0.24)	(+0.24)	(+0.24)	(+0.24)	(+0.24)	(+0.24)	(+0.24)	(+0.24)	(+0.24)	(+0.24)	(+0.24)	(+0.24)	(+0.24)	(+0.24)	(+0.24)	(+0.24)											
Grounding rings thick type (GRN, GRJ, GRW) with gaskets (GA, GC, GD) (*1)			+10	+10	+10	+10	+10	+10	+10	+10	+10	+10	+10	+10	+10	+10	+12	+12	-	-	-	-											
			(+0.39)	(+0.39)	(+0.39)	(+0.39)	(+0.39)	(+0.39)	(+0.39)	(+0.39)	(+0.39)	(+0.39)	(+0.39)	(+0.39)	(+0.39)	(+0.39)	(+0.47)	(+0.47)															
Grounding rings electrode type (GRP, GRT) (*1)			+28	+28	+28	+28	+28	+28	+28	+29	+29	+29	+29	+29	+29	+29	+29	+34	+34	-	-	-											
			(+1.10)	(+1.10)	(+1.10)	(+1.10)	(+1.10)	(+1.10)	(+1.10)	(+1.14)	(+1.14)	(+1.14)	(+1.14)	(+1.14)	(+1.14)	(+1.14)	(+1.14)	(+1.34)	(+1.34)														
Grounding rings electrode type (GRP, GRT) with gaskets (GA, GC, GD) (*1)			+32	+32	+32	+32	+32	+32	+32	+33	+33	+33	+33	+33	+33	+33	+40	+40	-	-	-	-											
			(+1.26)	(+1.26)	(+1.26)	(+1.26)	(+1.26)	(+1.26)	(+1.26)	(+1.30)	(+1.30)	(+1.30)	(+1.30)	(+1.30)	(+1.30)	(+1.30)	(+1.57)	(+1.57)															

- \*1: Add the value above (which is the total of both ends) to the lay length "L" when selecting optional grounding rings with/without gaskets.
- \*2: When submersible use or optional code DHC is selected, waterproof glands with union joints and cables are attached. When the cable length is 30-meters, add 9.5 kg (20.9 lb) to the weight in the table.
- \*3: The tolerance of the lay length "L" is as follows.
  - Size 2.5 to 200 mm (0.1 to 8 in.): 0/-3 mm
  - Size 250 to 400 mm (10 to 16 in.): 0/-5 mm

○ Flange, JIS 20K

Unit: mm (approx. in.)

Model	Process Connection Code	DJ2										BJ2									
		CJ2																			
		002	005	010	002	005	010	015	025	032	040	050	065	080	100	125	150	200	250	300	
Size Code	2.5	5	10	2.5	5	10	15	25	32	40	50	65	80	100	125	150	200	250	300		
Size	(0.1)	(0.2)	(0.4)	(0.1)	(0.2)	(0.4)	(0.5)	(1)	(1.25)	(1.5)	(2)	(2.5)	(3)	(4)	(5)	(6)	(8)	(10)	(12)		
Lining Code	A	A	A	A	A	A	A	A	A	A	A	A	A	A	A	A	A	A	A		
Remote Sensor	Lay Length (*1) (*3)	L	148	148	148	148	148	148	198	198	198	198	198	198	248	248	298	348	446	496	
			(5.83)	(5.83)	(5.83)	(5.83)	(5.83)	(5.83)	(7.80)	(7.78)	(7.78)	(7.78)	(7.78)	(7.78)	(9.74)	(9.74)	(11.71)	(13.68)	(17.54)	(19.51)	
	Flange Outer Diameter	øD	90	90	90	95	95	95	95	125	135	140	155	175	200	225	270	305	350	430	480
			(3.54)	(3.54)	(3.54)	(3.74)	(3.74)	(3.74)	(3.74)	(4.92)	(5.31)	(5.51)	(6.10)	(6.89)	(7.87)	(8.86)	(10.63)	(12.01)	(13.78)	(16.93)	(18.90)
	Flange Thickness (incl. lining flare)	t	18.0	18.0	18.0	20.0	20.0	20.0	17.0	22.0	23.0	23.0	25.0	27.0	29.0	31.0	32.5	34.5	39.0	40.0	40.0
			(0.71)	(0.71)	(0.71)	(0.79)	(0.79)	(0.79)	(0.67)	(0.87)	(0.91)	(0.91)	(0.91)	(0.98)	(1.06)	(1.14)	(1.22)	(1.28)	(1.36)	(1.54)	(1.57)
	Lining Inner Diameter	ød	2	5	8	2	5	8	13	24	29	37	49	61	73	97	121	145	194	243	292
			(0.09)	(0.19)	(0.30)	(0.09)	(0.19)	(0.30)	(0.51)	(0.93)	(1.13)	(1.44)	(1.94)	(2.40)	(2.87)	(3.82)	(4.76)	(5.72)	(7.65)	(9.55)	(11.51)
	Integral Flowmeter	Bolt	øC	65	65	65	70	70	70	90	100	105	120	140	160	185	225	260	305	380	430
				(2.56)	(2.56)	(2.56)	(2.76)	(2.76)	(2.76)	(3.54)	(3.94)	(4.13)	(4.72)	(5.51)	(6.30)	(7.28)	(8.86)	(10.24)	(12.01)	(14.96)	(16.93)
Integral Flowmeter	Bolt Hole Interval	ø*	45	45	45	45	45	45	45	45	45	45	45	45	45	45	45	45	45	45	
			(0.09)	(0.09)	(0.09)	(0.09)	(0.09)	(0.09)	(0.09)	(0.09)	(0.09)	(0.09)	(0.09)	(0.09)	(0.09)	(0.09)	(0.09)	(0.09)	(0.09)	(0.09)	(0.09)
Integral Flowmeter	Bolt Hole Diameter	øh	15	15	15	15	15	15	15	19	19	19	19	19	23	23	25	25	27	27	
			(0.59)	(0.59)	(0.59)	(0.59)	(0.59)	(0.59)	(0.59)	(0.75)	(0.75)	(0.75)	(0.75)	(0.75)	(0.91)	(0.91)	(0.98)	(0.98)	(1.06)	(1.06)	
Integral Flowmeter	Number of Bolt Holes	N	4	4	4	4	4	4	4	4	4	4	8	8	8	8	8	12	12	16	
Integral Flowmeter	Height	H1	164	164	164	164	164	164	164	143	154	156	177	196	214	237	273	295	343	413	463
			(6.46)	(6.46)	(6.46)	(6.46)	(6.46)	(6.46)	(6.46)	(5.63)	(6.06)	(6.14)	(6.97)	(7.72)	(8.43)	(9.33)	(10.75)	(11.61)	(13.49)	(16.27)	(18.22)
Integral Flowmeter	Height	H2	104	104	104	104	104	104	104	80	86	86	99	108	114	124	138	143	168	198	223
			(4.09)	(4.09)	(4.09)	(4.09)	(4.09)	(4.09)	(4.09)	(3.15)	(3.39)	(3.39)	(3.90)	(4.25)	(4.49)	(4.88)	(5.43)	(5.63)	(6.60)	(7.81)	(8.77)
Integral Flowmeter	Height	H3	-	-	-	-	-	-	-	-	-	-	-	-	-	-	-	-	481	531	
																				(18.94)	(20.91)
Remote Sensor	Maximum Height	Hr	281	281	281	281	281	281	281	260	271	273	294	313	331	354	390	412	460	531	580
			(11.06)	(11.06)	(11.06)	(11.06)	(11.06)	(11.06)	(11.06)	(10.24)	(10.67)	(10.75)	(11.57)	(12.32)	(13.03)	(13.94)	(15.35)	(16.23)	(18.11)	(20.89)	(22.84)
Remote Sensor	Approx. Weight, Unit: kg (lb) (*2)		3.7	3.7	3.7	3.9	3.9	3.9	4.0	5.2	6.3	6.6	7.5	9.9	13.1	17.7	26.5	36	51	90	108
			(8.2)	(8.2)	(8.2)	(8.6)	(8.6)	(8.6)	(8.8)	(11.5)	(13.9)	(14.6)	(16.5)	(21.8)	(28.9)	(39.0)	(58.4)	(79.5)	(112.6)	(198.7)	(238.4)
Integral Flowmeter	Maximum Height	Hi	326	326	326	326	326	326	326	305	316	318	339	358	376	399	435	457	505	575	625
			(12.83)	(12.83)	(12.83)	(12.83)	(12.83)	(12.83)	(12.83)	(12.01)	(12.44)	(12.52)	(13.35)	(14.09)	(14.80)	(15.71)	(17.13)	(17.99)	(19.87)	(22.65)	(24.60)
Integral Flowmeter	Approx. Weight, Unit: kg (lb)		6.3	6.3	6.3	6.5	6.5	6.5	6.6	7.7	8.8	9.2	10.0	12.5	15.6	20.2	29.1	39	53	92	111
			(13.9)	(13.9)	(13.9)	(14.3)	(14.3)	(14.3)	(14.6)	(17.0)	(19.4)	(20.3)	(22.1)	(27.6)	(34.4)	(44.5)	(64.2)	(86.1)	(117.0)	(203.1)	(245.0)
Grounding rings thin type (GRL, GRH, GRV) (*1)		+2	+2	+2	+2	+2	+2	+2	+2	+2	+2	+2	+2	+2	+2	+2	+2	+2	+4	+4	
Grounding rings thick type (GRN, GRJ, GRW) (*1)		+6	+6	+6	+6	+6	+6	+6	+6	+6	+6	+6	+6	+6	+6	+6	+6	+6	+6	+6	
Grounding rings thick type (GRN, GRJ, GRW) with gaskets (GA, GC, GD) (*1)		+10	+10	+10	+10	+10	+10	+10	+10	+10	+10	+10	+10	+10	+10	+10	+10	+10	+12	+12	
Grounding rings electrode type (GRP, GRT) (*1)		+28	+28	+28	+28	+28	+28	+28	+29	+29	+29	+29	+29	+29	+29	+29	+29	+29	+34	+34	
Grounding rings electrode type (GRP, GRT) with gaskets (GA, GC, GD) (*1)		+32	+32	+32	+32	+32	+32	+32	+33	+33	+33	+33	+33	+33	+33	+33	+33	+33	+40	+40	

- \*1: Add the value above (which is the total of both ends) to the lay length "L" when selecting optional grounding rings with/without gaskets.
- \*2: When submersible use or optional code DHC is selected, waterproof glands with union joints and cables are attached. When the cable length is 30-meters, add 9.5 kg (20.9 lb) to the weight in the table.
- \*3: The tolerance of the lay length "L" is as follows.
  - Size 2.5 to 200 mm (0.1 to 8 in.): 0/-3 mm
  - Size 250 to 400 mm (10 to 16 in.): 0/-5 mm

○ Flange, JPI Class 150

Unit: mm (approx. in.)

Model	Process Connection Code		BP1															
	Size Code		002	005	010	015	025	040	050	080	100	150	200	250	300	350	400	
	Size		2.5 (0.1)	5 (0.2)	10 (0.4)	15 (0.5)	25 (1)	40 (1.5)	50 (2)	80 (3)	100 (4)	150 (6)	200 (8)	250 (10)	300 (12)	350 (14)	400 (16)	
Lining Code		A	A	A	A	A	A	A	A	A	A	A	A	A	A	A		
Remote Sensor	Lay Length (*1) (*3)	L	148 (5.83)	148 (5.83)	148 (5.83)	198 (7.80)	198 (7.78)	198 (7.78)	198 (7.78)	248 (9.74)	298 (11.71)	348 (13.68)	446 (17.54)	496 (19.51)	546 (21.48)	596 (23.44)		
	Flange Outer Diameter	øD	90 (3.54)	90 (3.54)	90 (3.54)	90 (3.54)	110 (4.33)	125 (4.92)	150 (5.91)	190 (7.48)	230 (9.06)	280 (11.02)	345 (13.58)	405 (15.94)	485 (19.09)	535 (21.06)	595 (23.43)	
	Flange Thickness (incl. lining flare)	t	19.2 (0.76)	19.2 (0.76)	19.2 (0.76)	16.2 (0.64)	20.3 (0.80)	22.5 (0.89)	24.1 (0.95)	28.9 (1.14)	28.9 (1.14)	30.4 (1.20)	33.5 (1.32)	35.6 (1.40)	37.2 (1.46)	40.9 (1.61)	42.5 (1.67)	
	Lining Inner Diameter	ød	2 (0.09)	5 (0.19)	8 (0.30)	13 (0.51)	24 (0.93)	37 (1.44)	49 (1.94)	73 (2.87)	97 (3.82)	145 (5.72)	194 (7.65)	243 (9.55)	292 (11.51)	323 (12.73)	374 (14.70)	
	Bolt Circle Diameter	øC	60.3 (2.37)	60.3 (2.37)	60.3 (2.37)	60.3 (2.37)	79.4 (3.13)	98.4 (3.87)	120.7 (4.75)	152.4 (6.00)	190.5 (7.50)	241.3 (9.50)	298.5 (11.75)	362.0 (14.25)	431.8 (17.00)	476.3 (18.75)	539.8 (21.25)	
	Bolt Hole Interval	ø*	45	45	45	45	45	45	45	45	22.5	22.5	22.5	15	15	15	11.25	
	Bolt Hole Diameter	øh	16 (0.63)	16 (0.63)	16 (0.63)	16 (0.63)	16 (0.63)	16 (0.63)	19 (0.75)	19 (0.75)	19 (0.75)	22 (0.87)	22 (0.87)	22 (0.87)	26 (1.02)	26 (1.02)	29 (1.14)	29 (1.14)
	Number of Bolt Holes	N	4	4	4	4	4	4	4	4	8	8	8	8	12	12	12	16
	Height	H1	164 (6.46)	164 (6.46)	164 (6.46)	164 (6.46)	135 (5.31)	149 (5.87)	174 (6.85)	209 (8.23)	239 (9.41)	283 (11.12)	340 (13.39)	401 (15.78)	465 (18.32)	512 (20.14)	569 (22.41)	
	Height	H2	104 (4.09)	104 (4.09)	104 (4.09)	104 (4.09)	80 (3.15)	86 (3.39)	99 (3.90)	114 (4.49)	124 (4.88)	143 (5.61)	168 (6.60)	198 (7.81)	223 (8.77)	244 (9.61)	272 (10.70)	
Height	H3	-	-	-	-	-	-	-	-	-	-	-	456 (17.95)	536 (21.10)	595 (23.43)	655 (25.79)		
Remote Sensor	Maximum Height	Hr	281 (11.06)	281 (11.06)	281 (11.06)	281 (11.06)	252 (9.92)	266 (10.47)	291 (11.46)	326 (12.83)	356 (14.02)	400 (15.74)	457 (18.01)	518 (20.40)	583 (22.94)	629 (24.76)	687 (27.03)	
	Approx. Weight, Unit: kg (lb) (*2)		3.7 (8.2)	3.7 (8.2)	3.7 (8.2)	3.8 (8.4)	4.3 (9.5)	5.7 (12.6)	7.7 (17.0)	13.2 (29.1)	18.4 (40.6)	31 (68.4)	50 (110.4)	79 (174.4)	109 (240.6)	135 (298.0)	172 (379.7)	
Integral Flowmeter	Maximum Height	Hi	326 (12.83)	326 (12.83)	326 (12.83)	326 (12.83)	297 (11.69)	311 (12.24)	336 (13.23)	371 (14.61)	401 (15.79)	445 (17.50)	502 (19.77)	563 (22.16)	627 (24.69)	674 (26.52)	731 (28.79)	
	Approx. Weight, Unit: kg (lb)		6.1 (13.5)	6.1 (13.5)	6.1 (13.5)	6.2 (13.7)	6.8 (15.0)	8.2 (18.1)	10.1 (22.3)	15.7 (34.6)	20.8 (45.9)	34 (75.1)	52 (114.8)	81 (178.8)	111 (245.0)	138 (304.6)	175 (386.3)	
Grounding rings thin type (GRL, GRH, GRV) (*1)			+2 (+0.08)	+2 (+0.08)	+2 (+0.08)	+2 (+0.08)	+2 (+0.08)	+2 (+0.08)	+2 (+0.08)	+2 (+0.08)	+2 (+0.08)	+2 (+0.08)	+2 (+0.08)	+4 (+0.16)	+4 (+0.16)	+4 (+0.16)	+4 (+0.16)	
Grounding rings thick type (GRN, GRJ, GRW) (*1)			+6 (+0.24)	+6 (+0.24)	+6 (+0.24)	+6 (+0.24)	+6 (+0.24)	+6 (+0.24)	+6 (+0.24)	+6 (+0.24)	+6 (+0.24)	+6 (+0.24)	+6 (+0.24)	+6 (+0.24)	+6 (+0.24)	+6 (+0.24)	+6 (+0.24)	
Grounding rings thick type (GRN, GRJ, GRW) with gaskets (GA, GC, GD) (*1)			+10 (+0.39)	+10 (+0.39)	+10 (+0.39)	+10 (+0.39)	+10 (+0.39)	+10 (+0.39)	+10 (+0.39)	+10 (+0.39)	+10 (+0.39)	+12 (+0.47)	+12 (+0.47)	-	-	-	-	
Grounding rings electrode type (GRP, GRT) (*1)			+28 (+1.10)	+28 (+1.10)	+28 (+1.10)	+28 (+1.10)	+29 (+1.14)	+29 (+1.14)	+29 (+1.14)	+29 (+1.14)	+29 (+1.14)	+34 (+1.34)	+34 (+1.34)	-	-	-	-	
Grounding rings electrode type (GRP, GRT) with gaskets (GA, GC, GD) (*1)			+32 (+1.26)	+32 (+1.26)	+32 (+1.26)	+32 (+1.26)	+33 (+1.30)	+33 (+1.30)	+33 (+1.30)	+33 (+1.30)	+33 (+1.30)	+40 (+1.57)	+40 (+1.57)	-	-	-	-	

- \*1: Add the value above (which is the total of both ends) to the lay length "L" when selecting optional grounding rings with/without gaskets.
- \*2: When submersible use or optional code DHC is selected, waterproof glands with union joints and cables are attached. When the cable length is 30-meters, add 9.5 kg (20.9 lb) to the weight in the table.
- \*3: The tolerance of the lay length "L" is as follows.
  - Size 2.5 to 200 mm (0.1 to 8 in.): 0/-3 mm
  - Size 250 to 400 mm (10 to 16 in.): 0/-5 mm

○ Flange, AS Table D

Unit: mm (approx. in.)

Model	Process Connection Code		CS1								
	Size Code		050	080	100	150	200	250	300	350	400
	Size		50 (2)	80 (3)	100 (4)	150 (6)	200 (8)	250 (10)	300 (12)	350 (14)	400 (16)
Lining Code		A	A	A	A	A	A	A	A	A	
Remote Sensor	Lay Length (*1) (*3)	L	198 (7.78)	198 (7.78)	248 (9.74)	298 (11.71)	348 (13.68)	446 (17.54)	496 (19.51)	546 (21.48)	596 (23.44)
	Flange Outer Diameter	øD	150 (5.91)	185 (7.28)	215 (8.46)	280 (11.02)	335 (13.19)	405 (15.94)	455 (17.91)	525 (20.67)	580 (22.83)
	Flange Thickness (incl. lining flare)	t	13.0 (0.51)	15.0 (0.59)	15.0 (0.59)	17.9 (0.70)	17.9 (0.70)	21.4 (0.84)	24.4 (0.96)	27.9 (1.10)	27.9 (1.10)
	Lining Inner Diameter	ød	49 (1.94)	73 (2.87)	97 (3.82)	145 (5.72)	194 (7.65)	243 (9.55)	292 (11.51)	323 (12.73)	374 (14.70)
	Bolt Circle Diameter	øC	114 (4.49)	146 (5.75)	178 (7.01)	235 (9.25)	292 (11.50)	356 (14.02)	406 (15.98)	470 (18.50)	521 (20.51)
	Bolt Hole Interval	θ°	45	45	45	22.5	22.5	22.5	15	15	15
	Bolt Hole Diameter	øh	18 (0.71)	18 (0.71)	18 (0.71)	18 (0.71)	18 (0.71)	22 (0.87)	22 (0.87)	26 (1.02)	26 (1.02)
	Number of Bolt Holes	N	4	4	4	8	8	8	12	12	12
	Height	H1	174 (6.85)	207 (8.15)	232 (9.13)	283 (11.12)	335 (13.19)	401 (15.78)	450 (17.73)	507 (19.94)	562 (22.12)
	Height	H2	99 (3.90)	114 (4.49)	124 (4.88)	143 (5.61)	168 (6.60)	198 (7.81)	223 (8.77)	244 (9.61)	272 (10.70)
Height	H3	-	-	-	-	-	447 (17.58)	497 (19.55)	576 (22.68)	631 (24.84)	
Remote Sensor	Maximum Height	Hr	291 (11.46)	324 (12.76)	349 (13.74)	400 (15.74)	452 (17.81)	518 (20.40)	568 (22.34)	624 (24.56)	679 (26.74)
	Approx. Weight, Unit: kg (lb) (*2)		5.5 (12.1)	8.7 (19.2)	11.8 (26.0)	25 (55.2)	37 (81.7)	65 (143.5)	80 (176.6)	105 (231.8)	131 (289.2)
Integral Flowmeter	Maximum Height	Hi	336 (13.23)	369 (14.53)	394 (15.51)	445 (17.50)	497 (19.57)	563 (22.16)	612 (24.10)	669 (26.32)	724 (28.50)
	Approx. Weight, Unit: kg (lb)		7.9 (17.4)	11.1 (24.5)	14.2 (31.3)	27 (59.6)	39 (86.1)	67 (147.9)	82 (181.0)	107 (236.2)	133 (293.6)
Grounding rings thin type (GRL, GRH, GRV) (*1)			+2 (+0.08)	+2 (+0.08)	+2 (+0.08)	+2 (+0.08)	+2 (+0.08)	+4 (+0.16)	+4 (+0.16)	+4 (+0.16)	+4 (+0.16)
Grounding rings thick type (GRN, GRJ, GRW) (*1)			+6 (+0.24)	+6 (+0.24)	+6 (+0.24)	+6 (+0.24)	+6 (+0.24)	+6 (+0.24)	+6 (+0.24)	+6 (+0.24)	+6 (+0.24)
Grounding rings thick type (GRN, GRJ, GRW) with gaskets (GA, GC, GD) (*1)			+10 (+0.39)	+10 (+0.39)	+10 (+0.39)	+12 (+0.47)	+12 (+0.47)	-	-	-	-
Grounding rings electrode type (GRP, GRT) (*1)			+29 (+1.14)	+29 (+1.14)	+29 (+1.14)	+34 (+1.34)	+34 (+1.34)	-	-	-	-
Grounding rings electrode type (GRP, GRT) with gaskets (GA, GC, GD) (*1)			+33 (+1.30)	+33 (+1.30)	+33 (+1.30)	+40 (+1.57)	+40 (+1.57)	-	-	-	-

- \*1: Add the value above (which is the total of both ends) to the lay length "L" when selecting optional grounding rings with/without gaskets.
- \*2: When submersible use or optional code DHC is selected, waterproof glands with union joints and cables are attached. When the cable length is 30-meters, add 9.5 kg (20.9 lb) to the weight in the table.
- \*3: The tolerance of the lay length "L" is as follows.
  - Size 2.5 to 200 mm (0.1 to 8 in.): 0/-3 mm
  - Size 250 to 400 mm (10 to 16 in.): 0/-5 mm

○ Flange, AS Table E

Unit: mm (approx. in.)

Model	Process Connection Code		CS2						
	Size Code		050	080	100	150	200	250	300
	Size		50 (2)	80 (3)	100 (4)	150 (6)	200 (8)	250 (10)	300 (12)
Lining Code		A	A	A	A	A	A	A	
Remote Sensor Integral Flowmeter	Lay Length (*1) (*3)	L	198 (7.78)	198 (7.78)	248 (9.74)	298 (11.71)	348 (13.68)	446 (17.54)	496 (19.51)
	Flange Outer Diameter	øD	150 (5.91)	185 (7.28)	215 (8.46)	280 (11.02)	335 (13.19)	405 (15.94)	455 (17.91)
	Flange Thickness (incl. lining flare)	t	15.0 (0.59)	16.0 (0.63)	18.0 (0.71)	21.9 (0.86)	23.9 (0.94)	27.4 (1.08)	30.4 (1.20)
	Lining Inner Diameter	ød	49 (1.94)	73 (2.87)	97 (3.82)	145 (5.72)	194 (7.65)	243 (9.55)	292 (11.51)
	Bolt Circle Diameter	øC	114 (4.49)	146 (5.75)	178 (7.01)	235 (9.25)	292 (11.50)	356 (14.02)	406 (15.98)
	Bolt Hole Interval	ø*	45	45	22.5	22.5	22.5	15	15
	Bolt Hole Diameter	øh	18 (0.71)	18 (0.71)	18 (0.71)	22 (0.87)	22 (0.87)	22 (0.87)	26 (1.02)
	Number of Bolt Holes	N	4	4	8	8	8	12	12
	Height	H1	174 (6.85)	207 (8.15)	232 (9.13)	283 (11.12)	335 (13.19)	401 (15.78)	450 (17.73)
	Height	H2	99 (3.90)	114 (4.49)	124 (4.88)	143 (5.61)	168 (6.60)	198 (7.81)	223 (8.77)
	Height	H3	-	-	-	-	-	456 (17.95)	506 (19.92)
	Remote Sensor	Maximum Height	Hr	291 (11.46)	324 (12.76)	349 (13.74)	400 (15.74)	452 (17.81)	518 (20.40)
Approx. Weight, Unit: kg (lb) (*2)			5.9 (13.0)	8.9 (19.6)	12.5 (27.6)	28 (61.8)	42 (92.7)	72 (158.9)	89 (196.5)
Integral Flowmeter	Maximum Height	Hi	336 (13.23)	369 (14.53)	394 (15.51)	445 (17.50)	497 (19.57)	563 (22.16)	612 (24.10)
	Approx. Weight, Unit: kg (lb)		8.3 (18.3)	11.3 (24.9)	15.0 (33.1)	30 (66.2)	44 (97.1)	74 (163.4)	91 (200.9)
Grounding rings thin type (GRL, GRH, GRV) (*1)			+2 (+0.08)	+2 (+0.08)	+2 (+0.08)	+2 (+0.08)	+2 (+0.08)	+4 (+0.16)	+4 (+0.16)
Grounding rings thick type (GRN, GRJ, GRW) (*1)			+6 (+0.24)	+6 (+0.24)	+6 (+0.24)	+6 (+0.24)	+6 (+0.24)	+6 (+0.24)	+6 (+0.24)
Grounding rings thick type (GRN, GRJ, GRW) with gaskets (GA, GC, GD) (*1)			+10 (+0.39)	+10 (+0.39)	+10 (+0.39)	+12 (+0.47)	+12 (+0.47)	-	-
Grounding rings electrode type (GRP, GRT) (*1)			+29 (+1.14)	+29 (+1.14)	+29 (+1.14)	+34 (+1.34)	+34 (+1.34)	-	-
Grounding rings electrode type (GRP, GRT) with gaskets (GA, GC, GD) (*1)			+33 (+1.30)	+33 (+1.30)	+33 (+1.30)	+40 (+1.57)	+40 (+1.57)	-	-

- \*1: Add the value above (which is the total of both ends) to the lay length "L" when selecting optional grounding rings with/without gaskets.
- \*2: When submersible use or optional code DHC is selected, waterproof glands with union joints and cables are attached. When the cable length is 30-meters, add 9.5 kg (20.9 lb) to the weight in the table.
- \*3: The tolerance of the lay length "L" is as follows.
  - Size 2.5 to 200 mm (0.1 to 8 in.): 0/-3 mm
  - Size 250 to 400 mm (10 to 16 in.): 0/-5 mm



● Flange (PFA Lining, High Pressure Type)

Unit: mm (approx. in.)

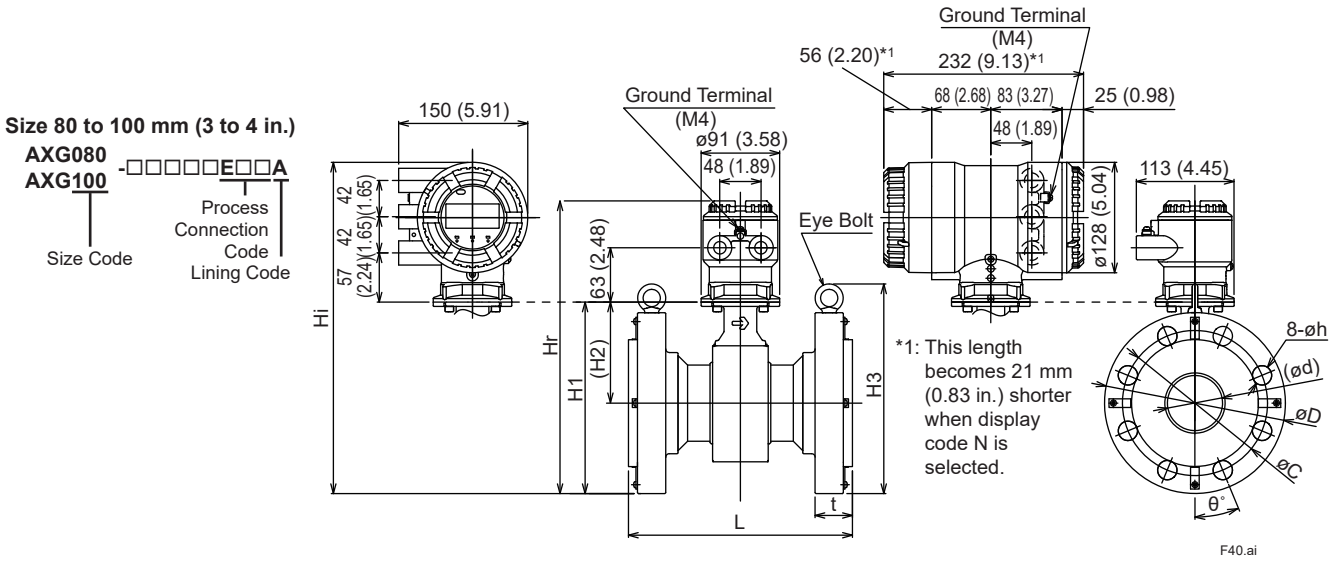
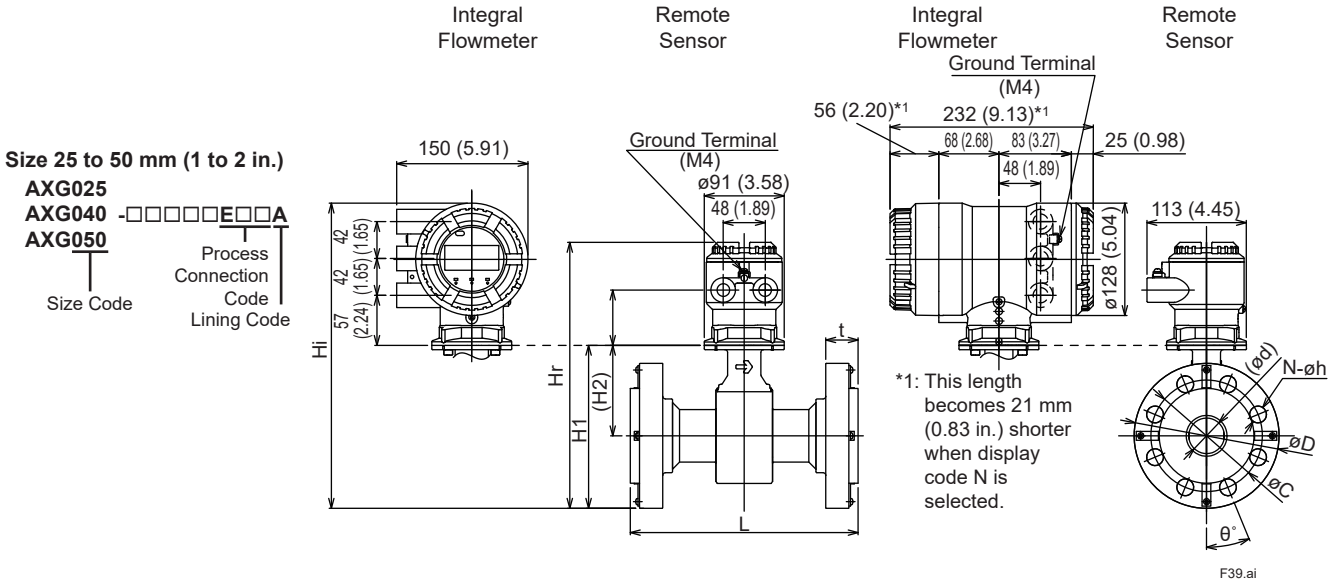

○ Flange, ASME Class 600

Unit: mm (approx. in.)

Model	Process Connection Code		EA4				
	Size Code		025	040	050	080	100
	Size		25 (1)	40 (1.5)	50 (2)	80 (3)	100 (4)
Lining Code		A	A	A	A	A	
Remote Sensor Integral Flowmeter	Lay Length (*1) (*3)	L	209 (8.23)	261 (10.28)	261 (10.28)	261 (10.28)	311 (12.24)
	Flange Outer Diameter	øD	124.0 (4.88)	155.5 (6.12)	165.1 (6.50)	209.6 (8.25)	273.1 (10.75)
	Flange Thickness (incl. lining flare)	t	29.0 (1.14)	34.4 (1.35)	37.4 (1.47)	43.8 (1.72)	50.1 (1.97)
	Lining Inner Diameter	ød	24 (0.93)	29 (1.16)	41 (1.59)	64 (2.52)	87 (3.43)
	Bolt Circle Diameter	øC	88.9 (3.50)	114.3 (4.50)	127.0 (5.00)	168.1 (6.62)	215.9 (8.50)
	Bolt Hole Interval	θ°	45	45	22.5	22.5	22.5
	Bolt Hole Diameter	øh	19.1 (0.75)	22.4 (0.88)	19.1 (0.75)	22.4 (0.88)	25.4 (1.00)
	Number of Bolt Holes	N	4	4	8	8	8
	Height	H1	148 (5.83)	167 (6.57)	185 (7.28)	222 (8.74)	265 (10.43)
	Height	H2	86 (3.38)	90 (3.53)	103 (4.05)	117 (4.61)	129 (5.07)
	Height	H3	-	-	-	243 (9.57)	306 (12.05)
	Remote Sensor	Maximum Height	Hr	265 (10.43)	284 (11.18)	302 (11.89)	339 (13.35)
Approx. Weight, Unit: kg (lb) (*2)			5.8 (12.8)	9.2 (20.3)	11.0 (24.3)	19.4 (42.8)	36.9 (81.4)
Integral Flowmeter	Maximum Height	Hi	310 (12.20)	329 (12.95)	347 (13.66)	384 (15.12)	427 (16.81)
	Approx. Weight, Unit: kg (lb)		8.2 (18.1)	11.6 (25.6)	13.4 (29.5)	21.9 (48.3)	39.3 (86.6)

\*1: The lay length "L" includes the thickness of the grounding rings (GRN) which always needs to be selected.

\*2: When submersible use or optional code DHC is selected, waterproof glands with union joints and cables are attached. When the cable length is 30-meters, add 9.5 kg (20.9 lb) to the weight in the table.

\*3: The tolerance of the lay length "L" is as follows.  
 • Size 2.5 to 200 mm (0.1 to 8 in.): 0/-3 mm

● Ceramics Tube (Union Joint)

Unit: mm (approx. in.)

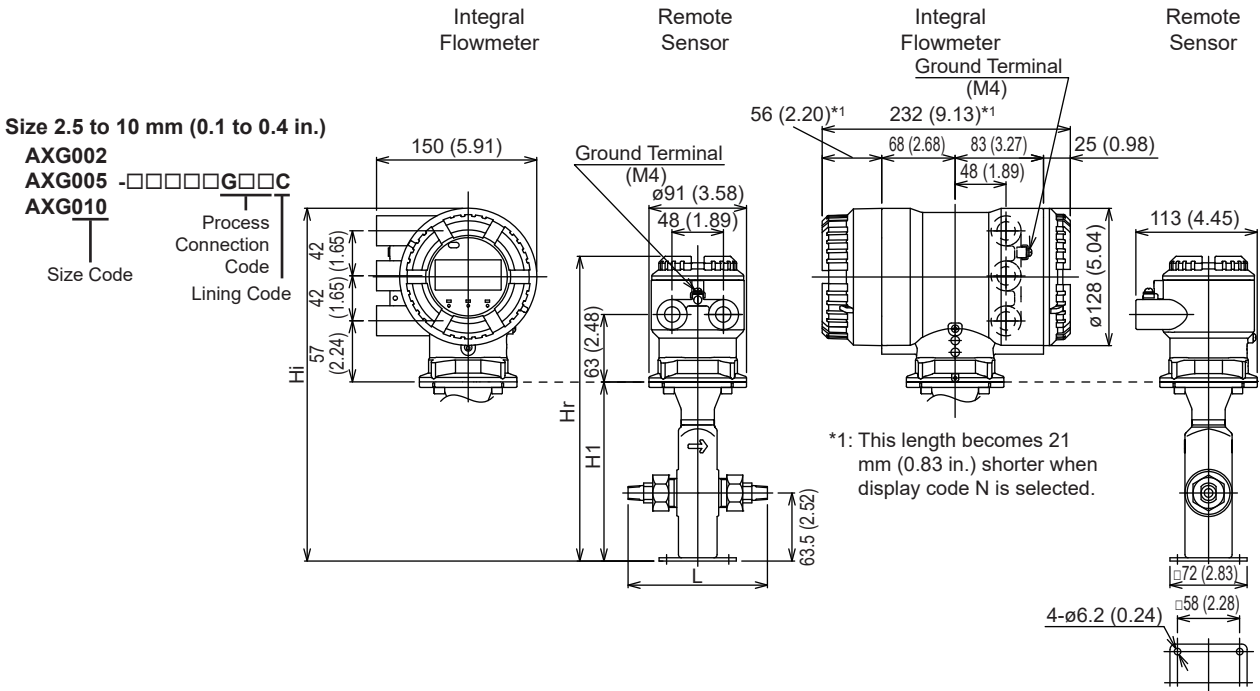

Unit: mm (approx. in.)

Model	Process Connection Code		GUN, GUR:			GUW:		
	Size Code		Screw Union Joint			Welding Union Joint		
	Size		002	005	010	002	005	010
	Lining Code		C	C	C	C	C	C
Remote Sensor	Lay Length	L	130 (5.12)			140 (5.51)		
	Height	H1	167 (6.57)			167 (6.57)		
Remote Sensor	Maximum Height	Hr	284 (11.18)			284 (11.18)		
	Approx. Weight, Unit: kg (lb) (*1)		2.7 (6.0)			2.7 (6.0)		
Integral Flowmeter	Maximum Height	Hi	329 (12.95)			329 (12.95)		
	Approx. Weight, Unit: kg (lb)		5.2 (11.5)			5.2 (11.5)		

\*1: When optional code DHC is selected, waterproof glands with union joints and cables are attached. When the cable length is 30-meters, add 9.5 kg (20.9 lb) to the weight in the table.

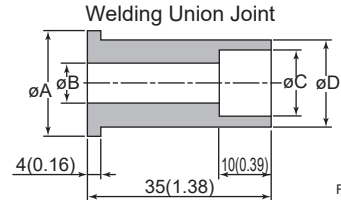
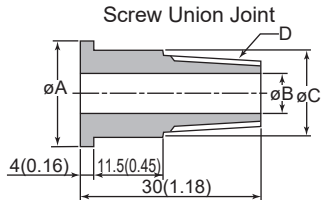

Process Connection Code	GUN: Screw Union Joint			
Size	øA	øB	øC	D
2.5(0.1)	22(0.87)	8(0.31)	18.5(0.73)	NPT1/4
5(0.2)	22(0.87)	8(0.31)	18.5(0.73)	NPT1/4
10(0.4)	25(0.98)	10(0.39)	22.5(0.89)	NPT3/8

Process Connection Code	GUR: Screw Union Joint			
Size	øA	øB	øC	D
2.5(0.1)	22(0.87)	8(0.31)	18.5(0.73)	R1/4
5(0.2)	22(0.87)	8(0.31)	18.5(0.73)	R1/4
10(0.4)	25(0.98)	10(0.39)	22.5(0.89)	R3/8

Process Connection Code	GUW: Welding Union Joint			
Size	øA	øB	øC	D
2.5(0.1)	22(0.87)	8(0.31)	14.3(0.56)	18.5(0.73)
5(0.2)	22(0.87)	8(0.31)	14.3(0.56)	18.5(0.73)
10(0.4)	25(0.98)	10(0.39)	17.8(0.70)	22.5(0.89)



Unit: mm (approx. in.)

Model	Process Connection Code		AA1, AA2, AJ1, AJ2							
			AE4				AE2			
			-	-	-	-	-	-	-	AE1
			-	-	-	-	-	-	-	-
Size Code		015	025	040	050	080	100	150	200	
Size		15 (0.5)	25 (1)	40 (1.5)	50 (2)	80 (3)	100 (4)	150 (6)	200 (8)	
Lining Code		C	C	C	C	C	C	C	C	
Remote Sensor	Lay Length (*1)	L	79 (3.11)	87 (3.43)	100 (3.94)	114 (4.49)	154 (6.06)	174 (6.85)	226 (8.90)	296 (11.65)
	Outer Diameter	øD	44 (1.73)	67.5 (2.66)	86 (3.39)	99 (3.90)	129 (5.08)	155 (6.10)	214 (8.43)	264 (10.39)
Integral Flowmeter	Pipe Inner Diameter	ød	13 (0.51)	23 (0.91)	36 (1.42)	48 (1.89)	73 (2.87)	93 (3.66)	141 (5.55)	187 (7.36)
	Height	H1	167 (6.57)	110 (4.33)	129 (5.08)	148 (5.83)	175 (6.89)	201 (7.91)	255 (10.04)	305 (12.02)
Remote Sensor	Maximum Height	Hr	284 (11.18)	227 (8.94)	246 (9.69)	265 (10.43)	292 (11.50)	318 (12.52)	372 (14.66)	423 (16.63)
	Approx. Weight, Unit: kg (lb) (*3)		2.7 (6.0)	2.7 (6.0)	3.6 (7.9)	4.5 (9.9)	7.2 (15.9)	10.1 (22.3)	21 (46.4)	34 (75.1)
Integral Flowmeter	Maximum Height	Hi	329 (12.95)	272 (10.71)	291 (11.46)	310 (12.20)	337 (13.27)	363 (14.29)	417 (16.42)	467 (18.39)
	Approx. Weight, Unit: kg (lb)		5.2 (11.5)	5.2 (11.5)	6.1 (13.5)	7.0 (15.4)	9.7 (21.4)	12.6 (27.8)	23 (50.8)	36 (79.5)
Gaskets (BSC, BSF) (*1)			+6 (+0.24)	+6 (+0.24)	+6 (+0.24)	+6 (+0.24)	+6 (+0.24)	+6 (+0.24)	+6 (+0.24)	+6 (+0.24)
Grounding rings thick type (GRN, GRJ, GRW) (*1)			+6 (+0.24)	+6 (+0.24)	+6 (+0.24)	+6 (+0.24)	+6 (+0.24)	+6 (+0.24)	+6 (+0.24)	+6 (+0.24)
Grounding rings thick type (GRN, GRJ, GRW) and gaskets (BSC, BSF) (*1)			+12 (+0.47)	+12 (+0.47)	+12 (+0.47)	+12 (+0.47)	+12 (+0.47)	+12 (+0.47)	+12 (+0.47)	+12 (+0.47)
Grounding rings thick type (GRN, GRJ, GRW) with gaskets (GA, GC, GD, GF) (*1) (*2)			+6 (+0.24)	+6 (+0.24)	+6 (+0.24)	+6 (+0.24)	+6 (+0.24)	+6 (+0.24)	+6 (+0.24)	+6 (+0.24)
Grounding rings thick type (GRN, GRJ, GRW) with gaskets (GA, GC, GD, GF) and gaskets (BSC, BSF) (*1) (*2)			+12 (+0.47)	+12 (+0.47)	+12 (+0.47)	+12 (+0.47)	+12 (+0.47)	+12 (+0.47)	+12 (+0.47)	+12 (+0.47)
Grounding rings electrode type (GRP, GRT) (*1)			+28 (+1.10)	+28 (+1.10)	+28 (+1.10)	+28 (+1.10)	+28 (+1.10)	+28 (+1.10)	+36 (+1.42)	+36 (+1.42)
Grounding rings electrode type (GRP, GRT) and gaskets (BSC, BSF) (*1)			+34 (+1.34)	+34 (+1.34)	+34 (+1.34)	+34 (+1.34)	+34 (+1.34)	+34 (+1.34)	+42 (+1.65)	+42 (+1.65)
Grounding rings electrode type (GRP, GRT) with gaskets (GA, GC, GD, GF) (*1) (*2)			+28 (+1.10)	+28 (+1.10)	+28 (+1.10)	+28 (+1.10)	+28 (+1.10)	+28 (+1.10)	+36 (+1.42)	+36 (+1.42)
Grounding rings electrode type (GRP, GRT) with gaskets (GA, GC, GD, GF) and gaskets (BSC, BSF) (*1) (*2)			+34 (+1.34)	+34 (+1.34)	+34 (+1.34)	+34 (+1.34)	+34 (+1.34)	+34 (+1.34)	+42 (+1.65)	+42 (+1.65)

- \*1: The lay length "L" includes the thickness of two gaskets which are supplied with the flowmeter. Be sure to always use the supplied gaskets. Add the value above (which is the total of both ends including the supplied two gaskets) to the lay length "L" when selecting optional grounding rings with/without gaskets.
- \*2: When the optional code GA, GC, GD, or GF is selected, two gaskets which are supplied with the flowmeter are changed to the gaskets selected by the optional code.
- \*3: When optional code DHC is selected, waterproof glands with union joints and cables are attached. When the cable length is 30-meters, add 9.5 kg (20.9 lb) to the weight in the table.

• Hygienic Use (Clamp, PFA Lining)

Unit: mm (approx. in.)

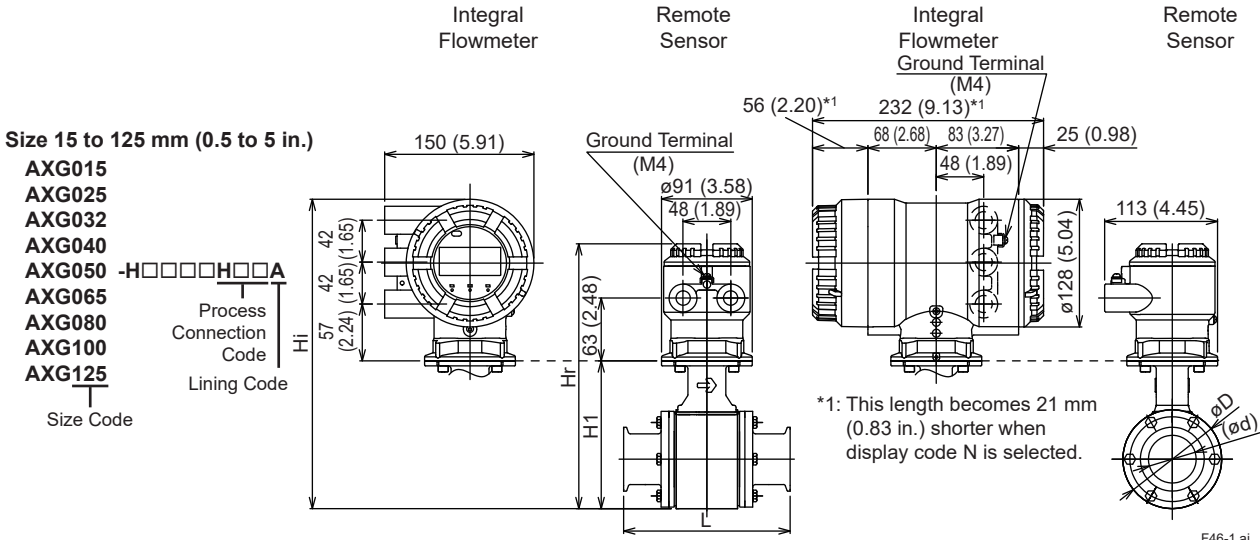

F46-1.ai

Unit: mm (approx. in.)

Model	Process Connection Code		HAB: Tri-Clamp (not applicable for size code 032 and 125) HDB: DIN 32676 Clamp HKB: ISO 2852 / SMS 3016 Clamp HJA, HJB: ISO 2852 Clamp (for JIS G3447 Piping)								
	Size Code		015	025	032	040	050	065	080	100	125
	Size		15	25	32	40	50	65	80	100	125
			(0.5)	(1)	(1.25)	(1.5)	(2)	(2.5)	(3)	(4)	(5)
Lining Code			A	A	A	A	A	A	A	A	
Remote Sensor	Lay Length	L	166 (6.54)	166 (6.54)	166 (6.54)	166 (6.54)	176 (6.93)	196 (7.72)	216 (8.50)	246 (9.69)	316 (12.44)
	Outer Diameter	øD	73 (2.87)	73 (2.87)	73 (2.87)	86 (3.39)	99 (3.90)	117 (4.61)	129 (5.08)	155 (6.10)	183 (7.20)
Integral Flowmeter	Inner Diameter	ød	17.5 (0.69)	23.0 (0.91)	29.4 (1.16)	35.7 (1.41)	47.8 (1.88)	59.5 (2.34)	72.3 (2.85)	97.6 (3.84)	133.8 (5.27)
	Height	H1	116 (4.57)	116 (4.57)	116 (4.57)	129 (5.08)	149 (5.87)	166 (6.54)	176 (6.93)	202 (7.95)	230 (9.06)
Remote Sensor	Maximum Height	Hr	233 (9.17)	233 (9.17)	233 (9.17)	246 (9.69)	266 (10.47)	283 (11.14)	293 (11.54)	319 (12.56)	347 (13.66)
	Approx. Weight, Unit: kg (lb) (*1)		3.1 (6.8)	2.9 (6.4)	3.0 (6.6)	3.3 (7.3)	4.1 (9.0)	5.4 (11.9)	6.4 (14.1)	9.1 (20.1)	13.5 (29.8)
Integral Flowmeter	Maximum Height	Hi	278 (10.94)	278 (10.94)	278 (10.94)	291 (11.46)	311 (12.24)	328 (12.91)	338 (13.31)	364 (14.33)	392 (15.43)
	Approx. Weight, Unit: kg (lb)		5.6 (12.4)	5.4 (11.9)	5.5 (12.1)	5.8 (12.8)	6.7 (14.8)	7.9 (17.4)	8.9 (19.6)	11.7 (25.8)	16.1 (35.5)

\*1: When optional code DHC is selected, waterproof glands with union joints and cables are attached. When the cable length is 30-meters, add 9.5 kg (20.9 lb) to the weight in the table.

○ Clamp Connection Adapter

Unit: mm (approx. in.)

Process Connection Code	HAB: Tri-Clamp						
	015	025	040	050	065	080	100
Size Code	15	25	40	50	65	80	100
Size	(0.5)	(1)	(1.5)	(2)	(2.5)	(3)	(4)
øA	70	70	83	96	114	126	152
	(2.76)	(2.76)	(3.27)	(3.78)	(4.49)	(4.96)	(5.98)
øB	16.0	22.2	34.6	47.6	59.5	72.3	97.0
	(0.63)	(0.87)	(1.36)	(1.87)	(2.34)	(2.85)	(3.82)
øC	19.2	25.4	38.1	50.8	63.5	76.2	101.6
	(0.76)	(1.00)	(1.50)	(2.00)	(2.50)	(3.00)	(4.00)
ød	15.7	22.1	34.8	47.5	60.2	72.9	97.4
	(0.62)	(0.87)	(1.37)	(1.87)	(2.37)	(2.97)	(3.83)
øE	-	43.6	43.6	56.3	70.6	83.3	110.3
		(1.72)	(1.72)	(2.22)	(2.78)	(3.28)	(4.34)
øF	25.0	50.4	50.4	64.0	77.4	91.0	118.9
	(0.98)	(1.98)	(1.98)	(2.52)	(3.05)	(3.58)	(4.68)
G	50	50	50	50	50	50	50
	(1.97)	(1.97)	(1.97)	(1.97)	(1.97)	(1.97)	(1.97)
Parts No. (HAB)	F9811 HU	F9811 HV	F9811 HX	F9811 HY	F9811 HZ	F9811 JA	F9811 JB

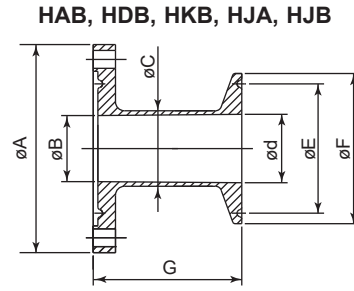

F46-2.ai

Clamp Connection Adapter

Unit: mm (approx. in.)

Process Connection Code	HDB: DIN 32676 Clamp								
	015	025	032	040	050	065	080	100	125
Size Code	15	25	32	40	50	65	80	100	125
Size	(0.5)	(1)	(1.25)	(1.5)	(2)	(2.5)	(3)	(4)	(5)
øA	70	70	70	83	96	114	126	152	180
	(2.76)	(2.76)	(2.76)	(3.27)	(3.78)	(4.49)	(4.96)	(5.98)	(7.09)
øB	16.0	22.2	29.4	34.6	47.6	59.5	72.3	97.0	121.0
	(0.63)	(0.87)	(1.16)	(1.36)	(1.87)	(2.34)	(2.85)	(3.82)	(4.76)
øC	20.0	30.0	36.0	42.0	54.0	70.0	85.0	104.0	129.0
	(0.79)	(1.18)	(1.42)	(1.65)	(2.13)	(2.76)	(3.35)	(4.09)	(5.08)
ød	16.0	26.0	32.0	38.0	50.0	66.0	81.0	100.0	125.0
	(0.63)	(1.02)	(1.26)	(1.50)	(1.97)	(2.60)	(3.19)	(3.94)	(4.92)
øE	27.5	43.5	43.5	43.5	56.5	83.5	97.0	110.0	146.0
	(1.08)	(1.71)	(1.71)	(1.71)	(2.22)	(3.29)	(3.82)	(4.33)	(5.75)
øF	34.0	50.5	50.5	50.5	64.0	91.0	106.0	119.0	155.0
	(1.34)	(1.99)	(1.99)	(1.99)	(2.52)	(3.58)	(4.17)	(4.69)	(6.10)
G	50	50	50	50	50	50	50	50	60
	(1.97)	(1.97)	(1.97)	(1.97)	(1.97)	(1.97)	(1.97)	(1.97)	(2.36)
Parts No. (HDB)	F9811 JD	F9811 JE	F9811 JF	F9811 JG	F9811 JH	F9811 JJ	F9811 JK	F9811 JL	F9870 ZD

Unit: mm (approx. in.)

Process Connection Code	HKB: ISO 2852 / SMS 3016 Clamp								
	015	025	032	040	050	065	080	100	125
Size Code	15	25	32	40	50	65	80	100	125
Size	(0.5)	(1)	(1.25)	(1.5)	(2)	(2.5)	(3)	(4)	(5)
øA	70	70	70	83	96	114	126	152	180
	(2.76)	(2.76)	(2.76)	(3.27)	(3.78)	(4.49)	(4.96)	(5.98)	(7.09)
øB	16.0	22.2	29.4	34.6	47.6	59.5	72.3	97.0	121.0
	(0.63)	(0.87)	(1.16)	(1.36)	(1.87)	(2.34)	(2.85)	(3.82)	(4.76)
øC	18.0	25.6	34.3	38.6	51.6	64.1	76.7	102.5	141.2
	(0.71)	(1.01)	(1.35)	(1.52)	(2.03)	(2.52)	(3.02)	(4.04)	(5.56)
ød	15.2	22.6	31.3	35.6	48.6	60.3	72.9	97.6	135.7
	(0.60)	(0.89)	(1.23)	(1.40)	(1.91)	(2.37)	(2.87)	(3.84)	(5.34)
øE	27.5	43.5	43.5	43.5	56.5	70.5	83.5	110.0	146.0
	(1.08)	(1.71)	(1.71)	(1.71)	(2.22)	(2.78)	(3.29)	(4.33)	(5.75)
øF	34.0	50.5	50.5	50.5	64.0	77.5	91.0	119.0	155.0
	(1.34)	(1.99)	(1.99)	(1.99)	(2.52)	(3.05)	(3.58)	(4.69)	(6.10)
G	50	50	50	50	50	50	50	50	60
	(1.97)	(1.97)	(1.97)	(1.97)	(1.97)	(1.97)	(1.97)	(1.97)	(2.36)
Parts No. (HKB)	F9811 JN	F9811 JP	F9811 JQ	F9811 JR	F9811 JS	F9811 JT	F9811 JU	F9811 JV	F9870 ZE

Unit: mm (approx. in.)

Process Connection Code	HJA, HJB: ISO 2852 Clamp (for JIS G3447 Piping)								
	015	025	032	040	050	065	080	100	125
Size Code	15	25	32	40	50	65	80	100	125
Size	(0.5)	(1)	(1.25)	(1.5)	(2)	(2.5)	(3)	(4)	(5)
øA	70	70	70	83	96	114	126	152	180
	(2.76)	(2.76)	(2.76)	(3.27)	(3.78)	(4.49)	(4.96)	(5.98)	(7.09)
øB	16.0	22.2	29.4	34.6	47.6	59.5	72.3	97.0	121.0
	(0.63)	(0.87)	(1.16)	(1.36)	(1.87)	(2.34)	(2.85)	(3.82)	(4.76)
øC	21.7	25.4	31.8	38.1	50.8	63.5	76.3	101.6	139.8
	(0.85)	(1.00)	(1.25)	(1.50)	(2.00)	(2.50)	(3.00)	(4.00)	(5.50)
ød	17.5	23.0	29.4	35.7	47.8	59.5	72.3	97.6	133.8
	(0.69)	(0.91)	(1.16)	(1.41)	(1.88)	(2.34)	(2.85)	(3.84)	(5.27)
øE	27.5	43.5	43.5	43.5	56.5	70.5	83.5	110.0	146.0
	(1.08)	(1.71)	(1.71)	(1.71)	(2.22)	(2.78)	(3.29)	(4.33)	(5.75)
øF	34.0	50.5	50.5	50.5	64.0	77.5	91.0	119.0	155.0
	(1.34)	(1.99)	(1.99)	(1.99)	(2.52)	(3.05)	(3.58)	(4.69)	(6.10)
G	50	50	50	50	50	50	50	50	60
	(1.97)	(1.97)	(1.97)	(1.97)	(1.97)	(1.97)	(1.97)	(1.97)	(2.36)
Parts No. (HJA)	F9811 HA	F9811 HB	F9811 HC	F9811 HD	F9811 HE	F9811 HF	F9811 HG	F9811 HH	F9870 ZA
Parts No. (HJB)	F9811 HK	F9811 HL	F9811 HM	F9811 HN	F9811 HP	F9811 HQ	F9811 HR	F9811 HS	F9870 ZB

● Hygienic Use (Clamp, PFA Lining) with Connection Parts for HJA and HJB (Optional code W2)

Unit: mm (approx. in.)

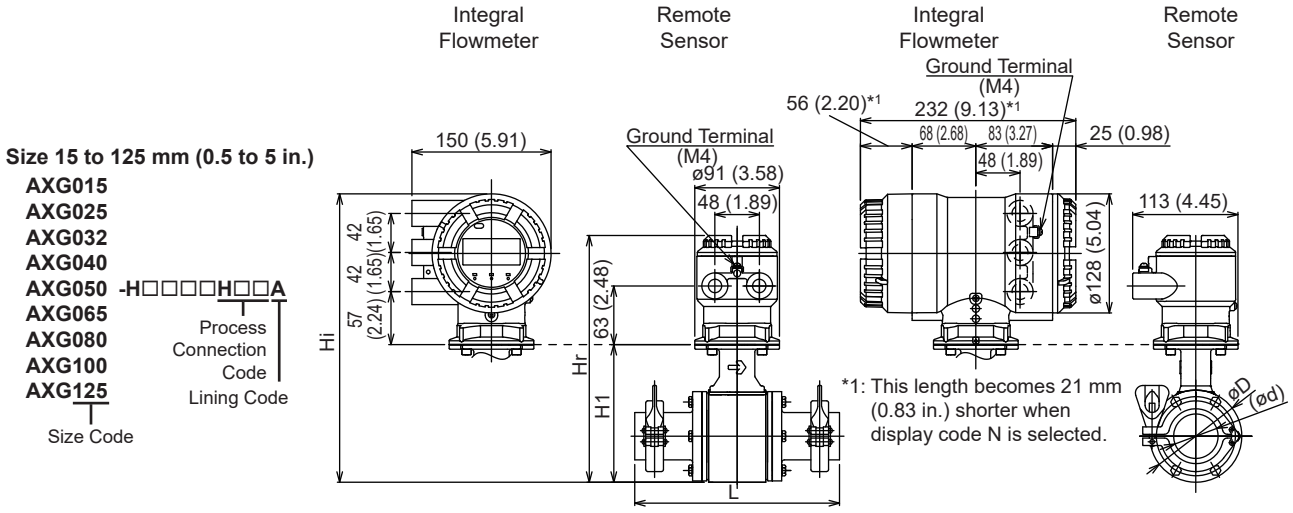

F47.ai

Unit: mm (approx. in.)

Model	Process Connection Code		HJA, HJB: ISO 2852 Clamp (for JIS G3447 Piping)								
	Size Code		015	025	032	040	050	065	080	100	125
	Size		15 (0.5)	25 (1)	32 (1.25)	40 (1.5)	50 (2)	65 (2.5)	80 (3)	100 (4)	125 (5)
	Lining Code		A	A	A	A	A	A	A	A	A
Remote Sensor	Lay Length	L	204 (8.03)	211 (8.31)	204 (8.03)	211 (8.31)	221 (8.70)	241 (9.49)	261 (10.28)	291 (11.46)	374 (14.72)
	Outer Diameter	øD	73 (2.87)	73 (2.87)	73 (2.87)	86 (3.39)	99 (3.90)	117 (4.61)	129 (5.08)	155 (6.10)	183 (7.20)
Integral Flowmeter	Inner Diameter	ød	17.5 (0.69)	23.0 (0.91)	29.4 (1.16)	35.7 (1.41)	47.8 (1.88)	59.5 (2.34)	72.3 (2.85)	97.6 (3.84)	133.8 (5.27)
	Height	H1	116 (4.57)	116 (4.57)	116 (4.57)	129 (5.08)	149 (5.87)	166 (6.54)	176 (6.93)	202 (7.95)	230 (9.06)
Remote Sensor	Maximum Height	Hr	233 (9.17)	233 (9.17)	233 (9.17)	246 (9.69)	266 (10.47)	283 (11.14)	293 (11.54)	319 (12.56)	347 (13.66)
	Approx. Weight, Unit: kg (lb) (*1)		3.0 (6.6)	2.7 (6.0)	2.9 (6.4)	3.2 (7.1)	3.9 (8.6)	5.1 (11.2)	5.9 (13.0)	8.1 (17.9)	12.3 (27.1)
Integral Flowmeter	Maximum Height	Hi	278 (10.94)	278 (10.94)	278 (10.94)	291 (11.46)	311 (12.24)	328 (12.91)	338 (13.31)	364 (14.33)	392 (15.43)
	Approx. Weight, Unit: kg (lb)		5.5 (12.1)	5.2 (11.5)	5.4 (11.9)	5.7 (12.6)	6.5 (14.3)	7.6 (16.8)	8.5 (18.7)	10.7 (23.6)	14.9 (32.9)

\*1 When optional code DHC is selected, waterproof glands with union joints and cables are attached. When the cable length is 30-meters, add 9.5 kg (20.9 lb) to the weight in the table.



• Hygienic Use (Union, PFA Lining)

Unit: mm (approx. in.)

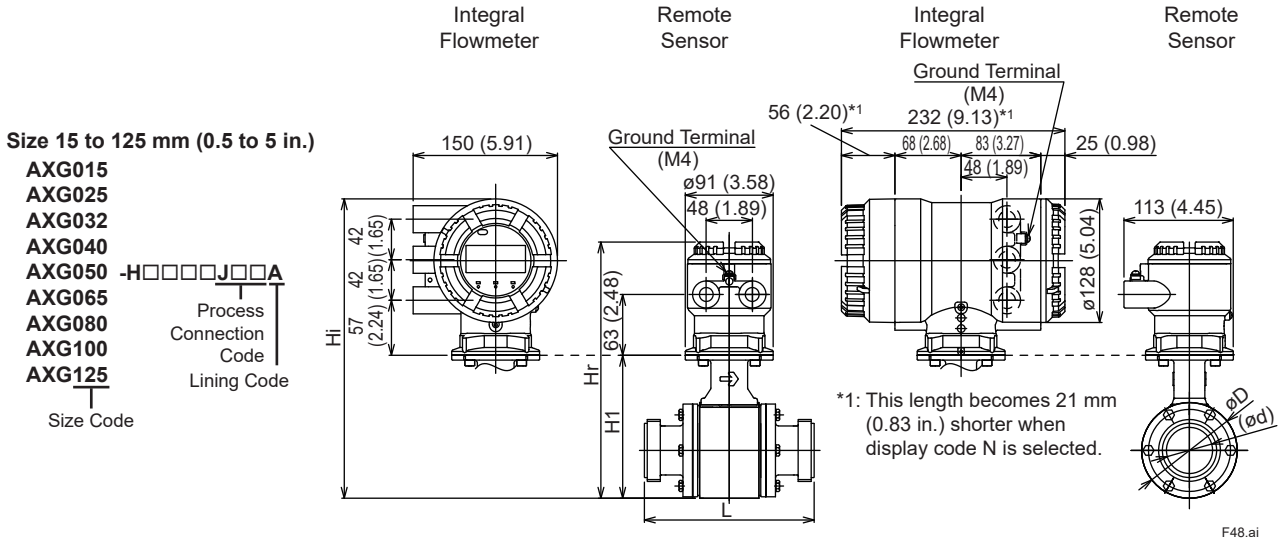

F48.ai

Unit: mm (approx. in.)

Model	Process Connection Code		JDB: DIN 11851 Union								
	Size Code		015	025	032	040	050	065	080	100	125
	Size		15 (0.5)	25 (1)	32 (1.25)	40 (1.5)	50 (2)	65 (2.5)	80 (3)	100 (4)	125 (5)
Lining Code		A	A	A	A	A	A	A	A	A	
Remote Sensor	Lay Length	L	166 (6.54)	166 (6.54)	166 (6.54)	166 (6.54)	176 (6.93)	196 (7.72)	236 (9.29)	266 (10.47)	326 (12.83)
	Outer Diameter	øD	73 (2.87)	73 (2.87)	73 (2.87)	86 (3.39)	99 (3.90)	117 (4.61)	129 (5.08)	155 (6.10)	183 (7.20)
Integral Flowmeter	Inner Diameter	ød	16 (0.63)	26 (1.02)	32 (1.26)	38 (1.50)	50 (1.97)	66 (2.60)	81 (3.19)	100 (3.94)	125 (4.92)
	Height	H1	116 (4.57)	116 (4.57)	116 (4.57)	129 (5.08)	149 (5.87)	166 (6.54)	176 (6.93)	202 (7.95)	230 (9.06)
Remote Sensor	Maximum Height	Hr	233 (9.17)	233 (9.17)	233 (9.17)	246 (9.69)	266 (10.47)	283 (11.14)	293 (11.54)	319 (12.56)	347 (13.66)
	Approx. Weight, Unit: kg (lb) (*1)		3.0 (6.6)	3.0 (6.6)	3.1 (6.8)	3.4 (7.5)	4.3 (9.5)	5.5 (12.1)	6.5 (14.3)	9.2 (20.3)	14.3 (31.5)
Integral Flowmeter	Maximum Height	Hi	278 (10.94)	278 (10.94)	278 (10.94)	291 (11.46)	311 (12.24)	328 (12.91)	338 (13.31)	364 (14.33)	392 (15.43)
	Approx. Weight, Unit: kg (lb)		5.5 (12.1)	5.5 (12.1)	5.6 (12.3)	5.9 (13.0)	6.9 (15.2)	8.0 (17.6)	9.1 (20.1)	11.8 (26.0)	16.9 (37.3)

\*1: When optional code DHC is selected, waterproof glands with union joints and cables are attached. When the cable length is 30-meters, add 9.5 kg (20.9 lb) to the weight in the table.

Unit: mm (approx. in.)

Model	Process Connection Code		JKB: ISO 2853 Union							
	Size Code		015	025	032	040	050	065	080	100
	Size		15 (0.5)	25 (1)	32 (1.25)	40 (1.5)	50 (2)	65 (2.5)	80 (3)	100 (4)
Lining Code		A	A	A	A	A	A	A	A	
Remote Sensor	Lay Length	L	166 (6.54)	166 (6.54)	166 (6.54)	166 (6.54)	176 (6.93)	196 (7.72)	216 (8.50)	246 (9.69)
	Outer Diameter	øD	73 (2.87)	73 (2.87)	73 (2.87)	86 (3.39)	99 (3.90)	117 (4.61)	129 (5.08)	155 (6.10)
Integral Flowmeter	Inner Diameter	ød	15.2 (0.60)	22.6 (0.89)	31.3 (1.23)	35.6 (1.40)	48.6 (1.91)	60.3 (2.37)	72.9 (2.87)	97.6 (3.84)
	Height	H1	116 (4.57)	116 (4.57)	116 (4.57)	129 (5.08)	149 (5.87)	166 (6.54)	176 (6.93)	202 (7.95)
Remote Sensor	Maximum Height	Hr	233 (9.17)	233 (9.17)	233 (9.17)	246 (9.69)	266 (10.47)	283 (11.14)	293 (11.54)	319 (12.56)
	Approx. Weight, Unit: kg (lb) (*1)		3.0 (6.6)	3.0 (6.6)	3.1 (6.8)	3.4 (7.5)	4.3 (9.5)	5.5 (12.1)	6.5 (14.3)	9.2 (20.3)
Integral Flowmeter	Maximum Height	Hi	278 (10.94)	278 (10.94)	278 (10.94)	291 (11.46)	311 (12.24)	328 (12.91)	338 (13.31)	364 (14.33)
	Approx. Weight, Unit: kg (lb)		5.5 (12.1)	5.5 (12.1)	5.6 (12.3)	5.9 (13.0)	6.9 (15.2)	8.0 (17.6)	9.1 (20.1)	11.8 (26.0)

Unit: mm (approx. in.)

Model	Process Connection Code		JJA, JJB: ISO 2853 Union (for JIS G3447 Piping)						
	Size Code		025	032	040	050	065	080	100
	Size		25 (1)	32 (1.25)	40 (1.5)	50 (2)	65 (2.5)	80 (3)	100 (4)
Lining Code		A	A	A	A	A	A	A	
Remote Sensor	Lay Length	L	166 (6.54)	166 (6.54)	166 (6.54)	176 (6.93)	196 (7.72)	216 (8.50)	246 (9.69)
	Outer Diameter	øD	73 (2.87)	73 (2.87)	86 (3.39)	99 (3.90)	117 (4.61)	129 (5.08)	155 (6.10)
Integral Flowmeter	Inner Diameter	ød	23.0 (0.91)	29.4 (1.16)	35.6 (1.40)	47.8 (1.88)	59.5 (2.34)	72.3 (2.85)	97.6 (3.84)
	Height	H1	116 (4.57)	116 (4.57)	129 (5.08)	149 (5.87)	166 (6.54)	176 (6.93)	202 (7.95)
Remote Sensor	Maximum Height	Hr	233 (9.17)	233 (9.17)	246 (9.69)	266 (10.47)	283 (11.14)	293 (11.54)	319 (12.56)
	Approx. Weight, Unit: kg (lb) (*1)		3.0 (6.6)	3.1 (6.8)	3.4 (7.5)	4.3 (9.5)	5.5 (12.1)	6.5 (14.3)	9.2 (20.3)
Integral Flowmeter	Maximum Height	Hi	278 (10.94)	278 (10.94)	291 (11.46)	311 (12.24)	328 (12.91)	338 (13.31)	364 (14.33)
	Approx. Weight, Unit: kg (lb)		5.5 (12.1)	5.6 (12.3)	5.9 (13.0)	6.9 (15.2)	8.0 (17.6)	9.1 (20.1)	11.8 (26.0)

Unit: mm (approx. in.)

Model	Process Connection Code		JSB: SMS 1145 Union (Open groove packing type)						
	Size Code		025	032	040	050	065	080	100
	Size		25 (1)	32 (1.25)	40 (1.5)	50 (2)	65 (2.5)	80 (3)	100 (4)
Lining Code		A	A	A	A	A	A	A	
Remote Sensor	Lay Length	L	166 (6.54)	166 (6.54)	166 (6.54)	176 (6.93)	196 (7.72)	216 (8.50)	276 (10.87)
	Outer Diameter	øD	73 (2.87)	73 (2.87)	86 (3.39)	99 (3.90)	117 (4.61)	129 (5.08)	155 (6.10)
Integral Flowmeter	Inner Diameter	ød	22.5 (0.89)	29.6 (1.17)	35.5 (1.40)	48.5 (1.91)	60.5 (2.38)	72.9 (2.87)	97.6 (3.84)
	Height	H1	116 (4.57)	116 (4.57)	129 (5.08)	149 (5.87)	166 (6.54)	176 (6.93)	202 (7.95)
Remote Sensor	Maximum Height	Hr	233 (9.17)	233 (9.17)	246 (9.69)	266 (10.47)	283 (11.14)	293 (11.54)	319 (12.56)
	Approx. Weight, Unit: kg (lb) (*1)		3.0 (6.6)	3.1 (6.8)	3.4 (7.5)	4.3 (9.5)	5.5 (12.1)	6.5 (14.3)	9.2 (20.3)
Integral Flowmeter	Maximum Height	Hi	278 (10.94)	278 (10.94)	291 (11.46)	311 (12.24)	328 (12.91)	338 (13.31)	364 (14.33)
	Approx. Weight, Unit: kg (lb)		5.5 (12.1)	5.6 (12.3)	5.9 (13.0)	6.9 (15.2)	8.0 (17.6)	9.1 (20.1)	11.8 (26.0)

\*1: When optional code DHC is selected, waterproof glands with union joints and cables are attached.  
When the cable length is 30-meters, add 9.5 kg (20.9 lb) to the weight in the table.

○ Union Connection Adapter

Unit: mm (approx. in.)

Process Connection Code	JDB: DIN 11851 Union								
Size Code	015	025	032	040	050	065	080	100	125
Size	15 (0.5)	25 (1)	32 (1.25)	40 (1.5)	50 (2)	65 (2.5)	80 (3)	100 (4)	125 (5)
øA	70 (2.76)	70 (2.76)	70 (2.76)	83 (3.27)	96 (3.78)	114 (4.49)	126 (4.96)	152 (5.98)	180 (7.09)
øB	16.0 (0.63)	22.2 (0.87)	29.4 (1.16)	34.6 (1.36)	47.6 (1.87)	59.5 (2.34)	72.3 (2.85)	97.0 (3.82)	121.0 (4.76)
øC	20.0 (0.79)	30.0 (1.18)	36.0 (1.42)	42.0 (1.65)	54.0 (2.13)	70.0 (2.76)	85.0 (3.35)	104.0 (4.09)	129.0 (5.08)
ød	16.0 (0.63)	26.0 (1.02)	32.0 (1.26)	38.0 (1.50)	50.0 (1.97)	66.0 (2.60)	81.0 (3.19)	100.0 (3.94)	125.0 (4.92)
øE	18.0 (0.71)	30.0 (1.18)	36.0 (1.42)	42.0 (1.65)	54.0 (2.13)	71.0 (2.80)	85.0 (3.35)	104.0 (4.09)	130.0 (5.12)
øF	25.8 (1.02)	39.8 (1.57)	45.8 (1.80)	51.8 (2.04)	63.8 (2.51)	80.8 (3.18)	94.8 (3.73)	113.8 (4.48)	141.8 (5.58)
G	RD34 x 1/8"	RD52 x 1/6"	RD58 x 1/6"	RD65 x 1/6"	RD78 x 1/6"	RD95 x 1/6"	RD110 x 1/4"	RD130 x 1/4"	RD160 x 1/4"
H	50 (1.97)	50 (1.97)	50 (1.97)	50 (1.97)	50 (1.97)	50 (1.97)	60 (2.36)	60 (2.36)	65 (2.56)
Parts No. (JDB)	F9811 KR	F9811 KS	F9811 KT	F9811 KU	F9811 KV	F9811 KW	F9811 KX	F9811 KY	F9870 ZH

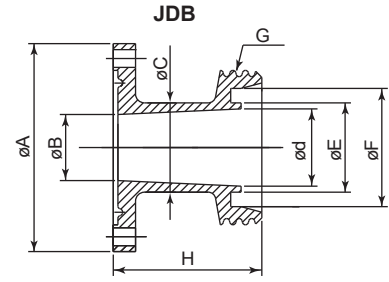

Unit: mm (approx. in.)

Process Connection Code	JKB: ISO 2853 Union							
Size Code	015	025	032	040	050	065	080	100
Size	15 (0.5)	25 (1)	32 (1.25)	40 (1.5)	50 (2)	65 (2.5)	80 (3)	100 (4)
øA	70 (2.76)	70 (2.76)	70 (2.76)	83 (3.27)	96 (3.78)	114 (4.49)	126 (4.96)	152 (5.98)
øB	16.0 (0.63)	22.2 (0.87)	29.4 (1.16)	34.6 (1.36)	47.6 (1.87)	59.5 (2.34)	72.3 (2.85)	97.0 (3.82)
øC	18.0 (0.71)	25.6 (1.01)	34.3 (1.35)	38.6 (1.52)	51.6 (2.03)	64.1 (2.52)	76.7 (3.02)	102.5 (4.04)
ød	15.2 (0.60)	22.6 (0.89)	31.3 (1.23)	35.6 (1.40)	48.6 (1.91)	60.3 (2.37)	72.9 (2.87)	97.6 (3.84)
øE	21.2 (0.83)	29.2 (1.15)	38.2 (1.50)	42.7 (1.68)	56.2 (2.21)	69.9 (2.75)	82.6 (3.25)	108.7 (4.28)
F	13.5 (0.53)	13.5 (0.53)	13.5 (0.53)	13.5 (0.53)	13.5 (0.53)	13.5 (0.53)	13.5 (0.53)	13.5 (0.53)
G	3 (0.12)	3 (0.12)	3 (0.12)	3 (0.12)	3 (0.12)	3 (0.12)	3 (0.12)	3 (0.12)
H	50 (1.97)	50 (1.97)	50 (1.97)	50 (1.97)	50 (1.97)	50 (1.97)	50 (1.97)	50 (1.97)
Parts No. (JKB)	F9811 LA	F9811 LB	F9811 LC	F9811 LD	F9811 LE	F9811 LF	F9811 LG	F9811 LH

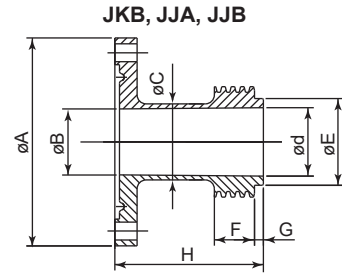

Unit: mm (approx. in.)

Process Connection Code	JJA, JJB: ISO 2853 Union (for JIS G3447 Piping)						
Size Code	025	032	040	050	065	080	100
Size	25 (1)	32 (1.25)	40 (1.5)	50 (2)	65 (2.5)	80 (3)	100 (4)
øA	70 (2.76)	70 (2.76)	83 (3.27)	96 (3.78)	114 (4.49)	126 (4.96)	152 (5.98)
øB	22.2 (0.87)	29.4 (1.16)	34.6 (1.36)	47.6 (1.87)	59.5 (2.34)	72.3 (2.85)	97.0 (3.82)
øC	25.6 (1.01)	31.8 (1.25)	38.0 (1.50)	51.0 (2.01)	63.5 (2.50)	76.3 (3.00)	101.6 (4.00)
ød	23.0 (0.91)	29.4 (1.16)	35.6 (1.40)	47.8 (1.88)	59.5 (2.34)	72.3 (2.85)	97.6 (3.84)
øE	29.2 (1.15)	35.7 (1.41)	42.7 (1.68)	56.2 (2.21)	69.9 (2.75)	82.6 (3.25)	108.7 (4.28)
F	13.5 (0.53)	10.0 (0.39)	13.5 (0.53)	13.5 (0.53)	13.5 (0.53)	13.5 (0.53)	18.0 (0.71)
G	3 (0.12)	2.5 (0.10)	3 (0.12)	3 (0.12)	3 (0.12)	3 (0.12)	3 (0.12)
H	50 (1.97)	50 (1.97)	50 (1.97)	50 (1.97)	50 (1.97)	50 (1.97)	50 (1.97)
Parts No. (JJA)	F9811 JY	F9811 JZ	F9811 KA	F9811 KB	F9811 KC	F9811 KD	F9811 KE
Parts No. (JJB)	F9811 KH	F9811 KJ	F9811 KK	F9811 KL	F9811 KM	F9811 KN	F9811 KP

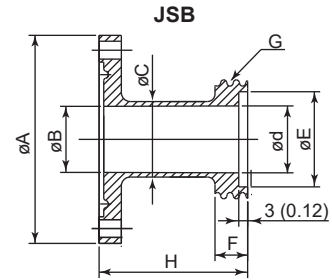

Union Connection Adapter

F49.ai

Unit: mm (approx. in.)

Process Connection Code	JSB: SMS 1145 Union (Open groove packing type)						
Size Code	025	032	040	050	065	080	100
Size	25 (1)	32 (1.25)	40 (1.5)	50 (2)	65 (2.5)	80 (3)	100 (4)
øA	70 (2.76)	70 (2.76)	83 (3.27)	96 (3.78)	114 (4.49)	126 (4.96)	152 (5.98)
øB	22.2 (0.87)	29.4 (1.16)	34.6 (1.36)	47.6 (1.87)	59.5 (2.34)	72.3 (2.85)	97.0 (3.82)
øC	25.4 (1.00)	32.0 (1.26)	38.1 (1.50)	51.0 (2.01)	63.5 (2.50)	76.2 (3.00)	102.5 (4.04)
ød	22.5 (0.89)	29.6 (1.17)	35.5 (1.40)	48.5 (1.91)	60.5 (2.38)	72.9 (2.87)	97.6 (3.84)
øE	32.0 (1.26)	40.0 (1.57)	48.0 (1.89)	61.0 (2.40)	73.5 (2.89)	86.0 (3.39)	120.0 (4.72)
F	11 (0.43)	13 (0.51)	15 (0.59)	15 (0.59)	19 (0.75)	19 (0.75)	30 (1.18)
G	RD40 x 1/6"	RD48 x 1/6"	RD60 x 1/6"	RD70 x 1/6"	RD85 x 1/6"	RD98 x 1/6"	RD132 x 1/6"
H	50 (1.97)	50 (1.97)	50 (1.97)	50 (1.97)	50 (1.97)	50 (1.97)	65 (2.56)
Parts No. (JSB)	F9811 LK	F9811 LL	F9811 LM	F9811 LN	F9811 LP	F9811 LQ	F9811 LR

• Hygienic Use (Union, PFA Lining) with Connection Parts for JJA and JJB (Optional code W2)

Unit: mm (approx. in.)

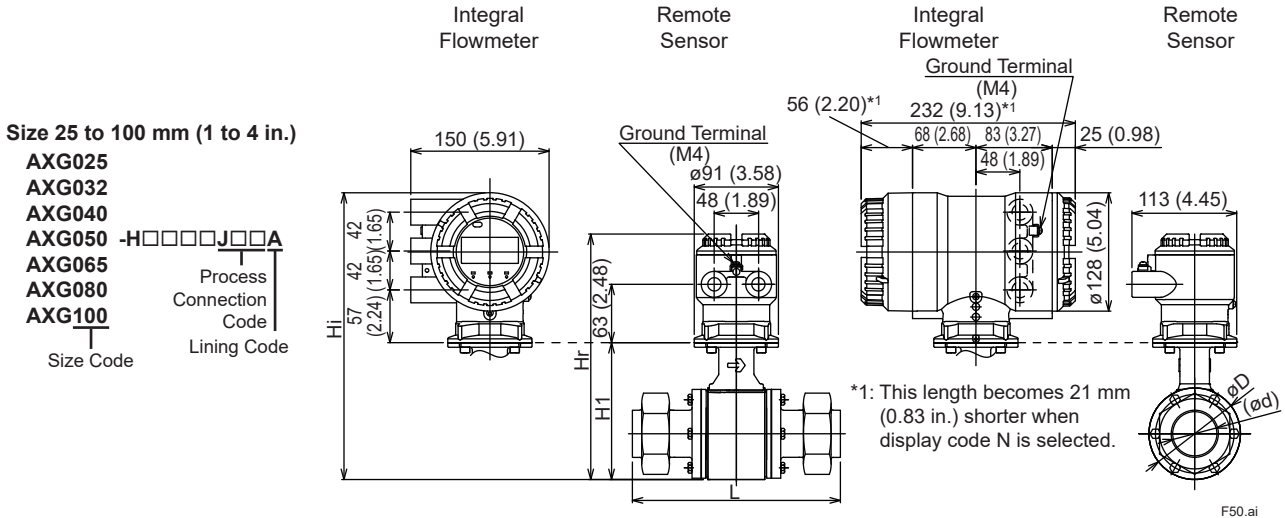

F50.ai

Unit: mm (approx. in.)

Model	Process Connection Code		JJA, JJB: ISO 2853 Union (for JIS G3447 Piping)							
	Size Code		025	032	040	050	065	080	100	
	Size		25 (1)	32 (1.25)	40 (1.5)	50 (2)	65 (2.5)	80 (3)	100 (4)	
Lining Code			A	A	A	A	A	A	A	
Remote Sensor	Lay Length	L	215 (8.46)	208 (8.19)	215 (8.46)	225 (8.86)	245 (9.65)	265 (10.43)	309 (12.17)	
	Outer Diameter	øD	73 (2.87)	73 (2.87)	86 (3.39)	99 (3.90)	117 (4.61)	129 (5.08)	155 (6.10)	
Integral Flowmeter	Inner Diameter	ød	23.0 (0.91)	29.4 (1.16)	35.7 (1.41)	47.8 (1.88)	59.5 (2.34)	72.3 (2.85)	97.6 (3.84)	
	Height	H1	116 (4.57)	116 (4.57)	129 (5.08)	149 (5.87)	166 (6.54)	176 (6.93)	202 (7.95)	
Remote Sensor	Maximum Height	Hr	233 (9.17)	233 (9.17)	246 (9.69)	266 (10.47)	283 (11.14)	293 (11.54)	319 (12.56)	
	Approx. Weight, Unit: kg (lb) (*1)		3.5 (7.7)	3.6 (7.9)	3.9 (8.6)	5.0 (11.0)	6.5 (14.3)	7.9 (17.4)	12.1 (26.7)	
Integral Flowmeter	Maximum Height	Hi	278 (10.94)	278 (10.94)	291 (11.46)	311 (12.24)	328 (12.91)	338 (13.31)	364 (14.33)	
	Approx. Weight, Unit: kg (lb) (*1)		6.0 (13.2)	6.1 (13.4)	6.4 (14.1)	7.6 (16.8)	9.0 (19.8)	10.5 (23.1)	14.7 (32.4)	

\*1 When optional code DHC is selected, waterproof glands with union joints and cables are attached. When the cable length is 30-meters, add 9.5 kg (20.9 lb) to the weight in the table.

● Hygienic Use (Butt Weld Joint, PFA Lining)

Unit: mm (approx. in.)

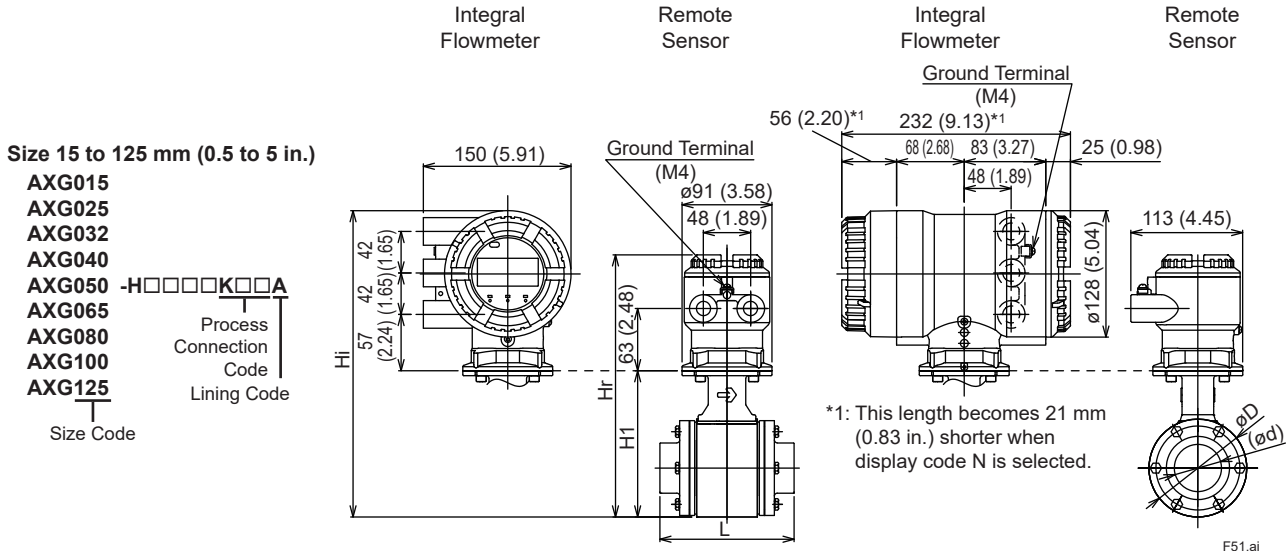

Unit: mm (approx. in.)

Model	Process Connection Code		KDB: DIN 11850 Piping Butt Weld Joint KKB: ISO 2037 Piping Butt Weld Joint KJA, KJB: JIS G3447 Piping Butt Weld Joint								
	Size Code		015	025	032	040	050	065	080	100	125
	Size		15	25	32	40	50	65	80	100	125
	Lining Code		A	A	A	A	A	A	A	A	A
Remote Sensor	Lay Length	L	126 (4.96)	126 (4.96)	126 (4.96)	126 (4.96)	136 (5.35)	156 (6.14)	176 (6.93)	206 (8.11)	276 (10.87)
	Outer Diameter	øD	73 (2.87)	73 (2.87)	73 (2.87)	86 (3.39)	99 (3.90)	117 (4.61)	129 (5.08)	155 (6.10)	183 (7.20)
Integral Flowmeter	Inner Diameter	ød	17.5 (0.69)	23.0 (0.91)	29.4 (1.16)	35.7 (1.41)	47.8 (1.88)	59.5 (2.34)	72.3 (2.85)	97.6 (3.84)	133.8 (5.27)
	Height	H1	116 (4.57)	116 (4.57)	116 (4.57)	129 (5.08)	149 (5.87)	166 (6.54)	176 (6.93)	202 (7.95)	230 (9.06)
Remote Sensor	Maximum Height	Hr	233 (9.17)	233 (9.17)	233 (9.17)	246 (9.69)	266 (10.47)	283 (11.14)	293 (11.54)	319 (12.56)	347 (13.66)
	Approx. Weight, Unit: kg (lb) (*1)		3.0 (6.6)	2.7 (6.0)	2.9 (6.4)	3.2 (7.1)	3.9 (8.6)	5.1 (11.2)	5.9 (13.0)	8.1 (17.9)	12.3 (27.1)
Integral Flowmeter	Maximum Height	Hi	278 (10.94)	278 (10.94)	278 (10.94)	291 (11.46)	311 (12.24)	328 (12.91)	338 (13.31)	364 (14.33)	392 (15.43)
	Approx. Weight, Unit: kg (lb)		5.5 (12.1)	5.2 (11.5)	5.4 (11.9)	5.7 (12.6)	6.5 (14.3)	7.6 (16.8)	8.5 (18.7)	10.7 (23.6)	14.9 (32.9)

\*1: When optional code DHC is selected, waterproof glands with union joints and cables are attached.  
When the cable length is 30-meters, add 9.5 kg (20.9 lb) to the weight in the table.

○ **Butt Weld Joint Adapter**

Unit: mm (approx. in.)

Process Connection Code	KDB: DIN 11850 Piping Butt Weld Joint								
	015	025	032	040	050	065	080	100	125
Size	15 (0.5)	25 (1)	32 (1.25)	40 (1.5)	50 (2)	65 (2.5)	80 (3)	100 (4)	125 (5)
øA	70 (2.76)	70 (2.76)	70 (2.76)	83 (3.27)	96 (3.78)	114 (4.49)	126 (4.96)	152 (5.98)	180 (7.09)
øB	16.0 (0.63)	22.2 (0.87)	29.4 (1.16)	34.6 (1.36)	47.6 (1.87)	59.5 (2.34)	72.3 (2.85)	97.0 (3.82)	121.0 (4.76)
øC	20.0 (0.79)	30.0 (1.18)	36.0 (1.42)	42.0 (1.65)	54.0 (2.13)	70.0 (2.76)	85.0 (3.35)	104.0 (4.09)	129.0 (5.08)
ød	16.0 (0.63)	26.0 (1.02)	32.0 (1.26)	38.0 (1.50)	50.0 (1.97)	66.0 (2.60)	81.0 (3.19)	100.0 (3.94)	125.0 (4.92)
E	30 (1.18)	30 (1.18)	30 (1.18)	30 (1.18)	30 (1.18)	30 (1.18)	30 (1.18)	30 (1.18)	40 (1.57)
Parts No. (KDB)	F9811 ND	F9811 NE	F9811 NF	F9811 NG	F9811 NH	F9811 NJ	F9811 NK	F9811 NL	F9870 ZP

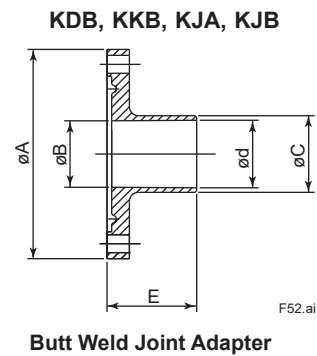

Unit: mm (approx. in.)

Process Connection Code	KKB: ISO 2037 Piping Butt Weld Joint								
	015	025	032	040	050	065	080	100	125
Size	15 (0.5)	25 (1)	32 (1.25)	40 (1.5)	50 (2)	65 (2.5)	80 (3)	100 (4)	125 (5)
øA	70 (2.76)	70 (2.76)	70 (2.76)	83 (3.27)	96 (3.78)	114 (4.49)	126 (4.96)	152 (5.98)	180 (7.09)
øB	16.0 (0.63)	22.2 (0.87)	29.4 (1.16)	34.6 (1.36)	47.6 (1.87)	59.5 (2.34)	72.3 (2.85)	97.0 (3.82)	121.0 (4.76)
øC	18.0 (0.71)	25.6 (1.01)	34.3 (1.35)	38.6 (1.52)	51.6 (2.03)	64.1 (2.52)	76.7 (3.02)	102.5 (4.04)	141.2 (5.56)
ød	15.2 (0.60)	22.6 (0.89)	31.3 (1.23)	35.6 (1.40)	48.6 (1.91)	60.3 (2.37)	72.9 (2.87)	97.6 (3.84)	135.7 (5.34)
E	30 (1.18)	30 (1.18)	30 (1.18)	30 (1.18)	30 (1.18)	30 (1.18)	30 (1.18)	30 (1.18)	40 (1.57)
Parts No. (KKB)	F9811 NN	F9811 NP	F9811 NQ	F9811 NR	F9811 NS	F9811 NT	F9811 NU	F9811 NV	F9870 ZQ

Unit: mm (approx. in.)

Process Connection Code	KJA, KJB: JIS G3447 Piping Butt Weld Joint								
	015	025	032	040	050	065	080	100	125
Size	15 (0.5)	25 (1)	32 (1.25)	40 (1.5)	50 (2)	65 (2.5)	80 (3)	100 (4)	125 (5)
øA	70 (2.76)	70 (2.76)	70 (2.76)	83 (3.27)	96 (3.78)	114 (4.49)	126 (4.96)	152 (5.98)	180 (7.09)
øB	16.0 (0.63)	22.2 (0.87)	29.4 (1.16)	34.6 (1.36)	47.6 (1.87)	59.5 (2.34)	72.3 (2.85)	97.0 (3.82)	121.0 (4.76)
øC	21.7 (0.85)	25.4 (1.00)	31.8 (1.25)	38.1 (1.50)	50.8 (2.00)	63.5 (2.50)	76.3 (3.00)	101.6 (4.00)	139.8 (5.50)
ød	17.5 (0.69)	23.0 (0.91)	29.4 (1.16)	35.7 (1.41)	47.8 (1.88)	59.5 (2.34)	72.3 (2.85)	97.6 (3.84)	133.8 (5.27)
E	30 (1.18)	30 (1.18)	30 (1.18)	30 (1.18)	30 (1.18)	30 (1.18)	30 (1.18)	30 (1.18)	40 (1.57)
Parts No. (KJA)	F9811 MA	F9811 MB	F9811 MC	F9811 MD	F9811 ME	F9811 MF	F9811 MG	F9811 MH	F9870 ZL
Parts No. (KJB)	F9811 MK	F9811 ML	F9811 MM	F9811 MN	F9811 MP	F9811 MQ	F9811 MR	F9811 MS	F9870 ZM

## (2) AXG4A Remote Transmitter

Unit: mm (approx. in.)

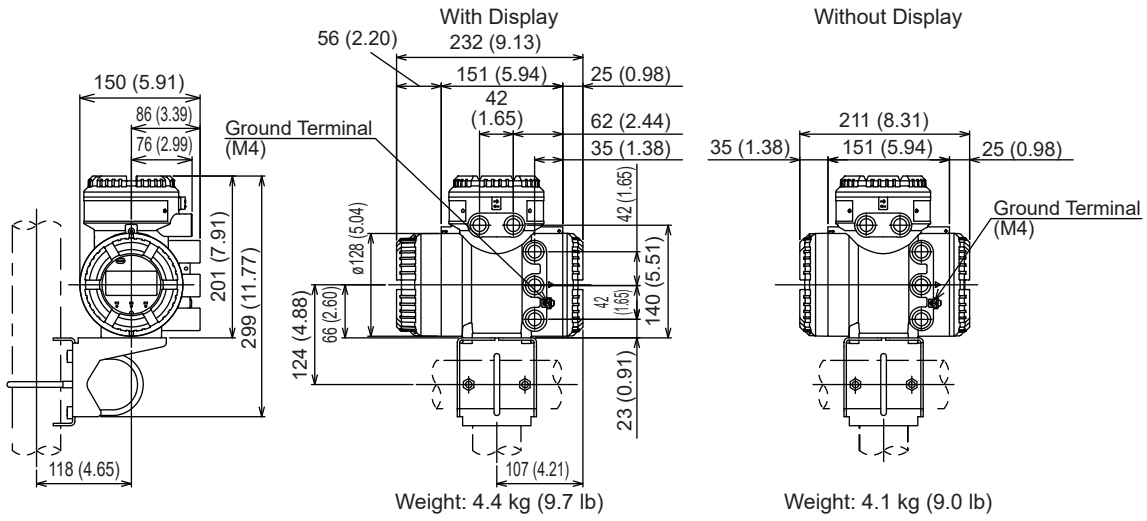

F53.ai

**(3) AX01C Magnetic Flowmeter Signal Cable**

**Cable Finish: Finished**

Unit: mm (approx. in.)

AX01C-■□□□  
 ■=C, D

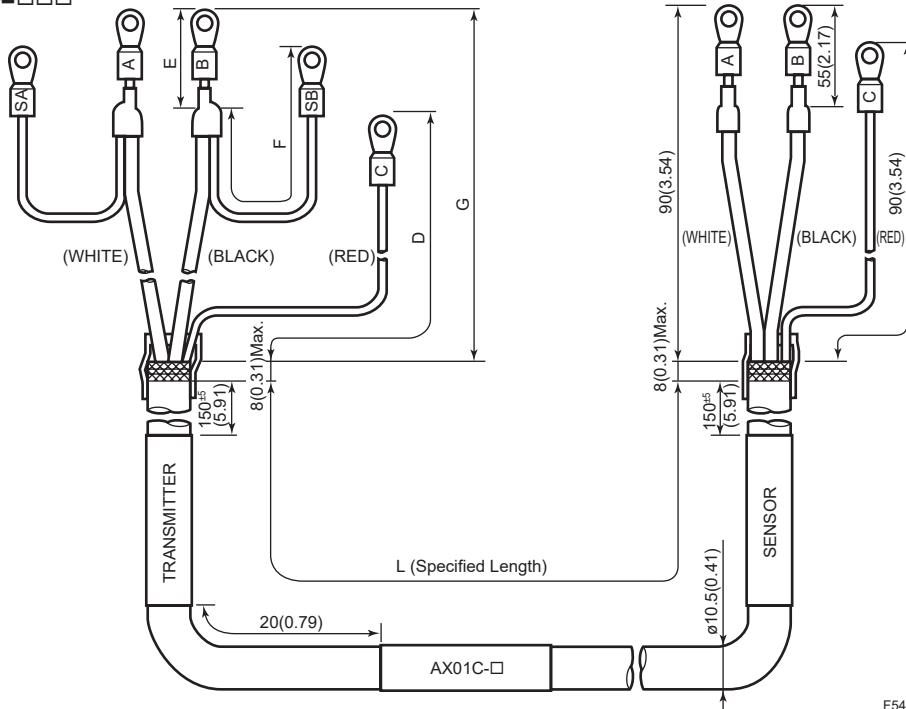

F54.ai

Unit: mm (approx. in.)

Specification Code	Length				Description
	D	E	F	G	
AX01C-C□□□	60 (2.4)	25 (1.0)	70 (2.8)	50 (2.0)	For AXG4A
AX01C-D□□□	70 (2.8)	25 (1.0)	50 (2.0)	60 (2.4)	For AXFA11

**Cable Finish: Unfinished**

AX01C-■□□□  
 ■=A

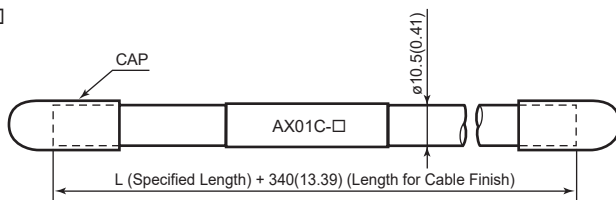

F55.ai



**(4) Dimensional Tolerance**

Unless otherwise specified, dimensional tolerances on the drawings are as shown in the following table.

General tolerance in the dimensional outline drawing.

Unit: mm (approx. in.)

Category of basic dimension		Tolerance	Category of basic dimension		Tolerance
Above	Equal or below		Above	Equal or below	
	3 (0.12)	±0.7 (±0.03)	500 (19.69)	630 (24.80)	±5.5 (±0.22)
3 (0.12)	6 (0.24)	±0.9 (±0.04)	630 (24.80)	800 (31.50)	±6.25 (±0.25)
6 (0.24)	10 (0.39)	±1.1 (±0.04)	800 (31.50)	1000 (39.37)	±7.0 (±0.28)
10 (0.39)	18 (0.71)	±1.35 (±0.05)	1000 (39.37)	1250 (49.21)	±8.25 (±0.32)
18 (0.71)	30 (1.18)	±1.65 (±0.06)	1250 (49.21)	1600 (62.99)	±9.75 (±0.38)
30 (1.18)	50 (1.97)	±1.95 (±0.08)	1600 (62.99)	2000 (78.74)	±11.5 (±0.45)
50 (1.97)	80 (3.15)	±2.3 (±0.09)	2000 (78.74)	2500 (98.43)	±14.0 (±0.55)
80 (3.15)	120 (4.72)	±2.7 (±0.11)	2500 (98.43)	3150 (124.02)	±16.5 (±0.65)
120 (4.72)	180 (7.09)	±3.15 (±0.12)			
180 (7.09)	250 (9.84)	±3.6 (±0.14)			
250 (9.84)	315 (12.40)	±4.05 (±0.16)			
315 (12.40)	400 (15.75)	±4.45 (±0.18)			
400 (15.75)	500 (19.69)	±4.85 (±0.19)			

Remarks: The numeric is based on criteria of tolerance class IT18 in JIS B 0401-1.

**■ SIZING DATA**

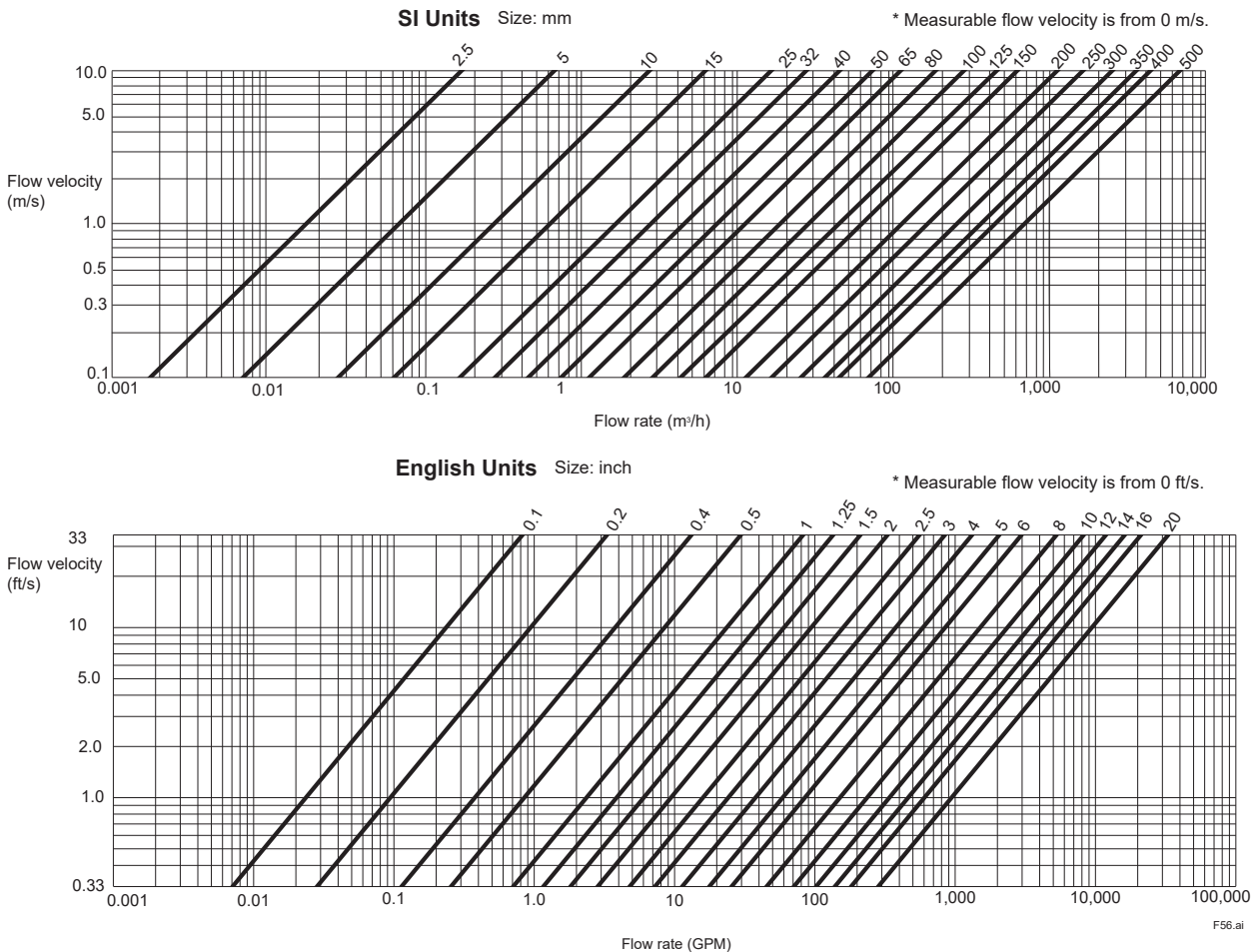

## ■ ORDERING INFORMATION

- Note 1:** When ordering, the span flow rate, unit, output pulse weight, and totalizer display pulse weight can be specified. These parameters will then be set before shipment. In the case of remote type, specify combination information of sensor and transmitter. These parameters will be set in the combined transmitter. When ordering of a remote sensor alone or a remote transmitter alone, these parameters cannot be specified. Custom configuration request is necessary for setting these parameters out of regular setting range.
- Note 2:** Some options, if ordered, require the relevant specifications to be input when ordering.
- Note 3:** For AXFA11G remote transmitter, read general specifications (GS 01E20C01-01E). The contents and conditions of ordering informations are different.

1. Model, Suffix Code and Optional Code
2. Combination

This is necessary when ordering combination of remote sensor and transmitter. Specify the combination of a sensor and a transmitter one by one by their model name, specification code, or Tag No. etc. On the nameplate of each sensor and transmitter, the serial number of the specified combination partner is described when shipped.

3. Tag No.

The Tag No. can be specified by a combination of uppercase letters, lowercase letters (for HART communication excludes lower case letters), numbers, "-" (hyphen), "." (period)", and " (space)". See the table below for specifying procedure.

Items to be Specified	Described / Setting Destination	Maximum Number of Characters
TAG NO	<ul style="list-style-type: none"> <li>Nameplate</li> <li>Stainless steel tag plate (with optional code SCT)</li> <li>Memory in transmitter</li> </ul>	30 (*1)
SOFTWARE TAG	<ul style="list-style-type: none"> <li>Memory in transmitter (Overrides TAG NO designation)</li> </ul>	See below

In the case of integral flowmeter and remote transmitter, the characters specified by "TAG NO" are also written to the memory (parameter) in the transmitter. If it is necessary to specify a different tag number only for the transmitter memory, specify "SOFTWARE TAG". It is also possible to specify only SOFTWARE TAG. Names of the parameter to be written and the maximum number of characters are as shown in the table below. If the number of specified characters exceed the maximum number, the characters from the beginning up to the maximum number is written.

Items to be Specified	Transmitter Memory		Maximum Number of Characters
	Communication	Parameter Name	
TAG NO and SOFTWARE TAG	BRAIN	TAG NO	16
	HART 7	Long Tag	30 (*1)
		Tag	8

\*1: For AXFA11G remote transmitter, the "TAG NO" is maximum 16 characters. And as its HART protocol is HART 5, the "Long Tag" is not available.

4. Span Flow Rate and Unit

Specify the range of span flow rate in the range of 0.0001 to 999999000000.0000 (the number of significant digits in operation is the upper six digits). Up to four digits below the decimal point that can be specified (by 0.001 unit). However, if the transmitter is BRAIN communication type, specify so that it is within the range of 0.0001 to 32000, it is up to four digits below the decimal point when it is included, and the numerical value excluding the decimal point is within 32000.

Specify units in the unit described in "Flow Calculation Function". This span flow rate is set to the positive first range. Be sure to specify the span flow rate and unit when selecting the Mass Unit Setting (optional code MU), or Specified Span Five-point Calibration (optional code SC).

Unless specified, it is set as the following when shipped.

- Integral Flowmeter, or combined with AXG4A Remote Transmitter span flow rate (unit m<sup>3</sup>/h) equivalent to flow velocity 1 m/s
- Combined with AXFA11 Remote Transmitter flow velocity 1 m/s

The measurement flow range (minimum and maximum of span flow rate) is shown below (in the case of flow rate unit m<sup>3</sup>/h and GPM). Specify the span flow within this range. The range specifying different unit must also fall into the same flow rate (flow velocity) range after conversion.

### Measurable Flow Rate Range

- (1) Integral Flowmeter, or combined with AXG4A Remote Transmitter

SI Units (Size: mm, Flow rate: m<sup>3</sup>/h)

Size (mm)	0 to Min. Span Flow Rate	0 to Max. Span Flow Rate
	m <sup>3</sup> /h (0.1 m/s)	m <sup>3</sup> /h (10 m/s)
2.5	0 to 0.0018	0 to 0.1767
5	0 to 0.0071	0 to 0.7068
10	0 to 0.0283	0 to 2.8274
15	0 to 0.0637	0 to 6.3617
25	0 to 0.1768	0 to 17.6714
32	0 to 0.2896	0 to 28.9529
40	0 to 0.4524	0 to 45.2389
50	0 to 0.7069	0 to 70.6858
65	0 to 1.1946	0 to 119.459
80	0 to 1.8096	0 to 180.955
100	0 to 2.8275	0 to 282.743
125	0 to 4.4179	0 to 441.786
150	0 to 6.3618	0 to 636.172
200	0 to 11.3098	0 to 1130.97
250	0 to 17.6715	0 to 1767.14
300	0 to 25.4470	0 to 2544.69
350	0 to 34.6361	0 to 3463.60
400	0 to 45.2390	0 to 4523.89

English Units (Size: in., Flow rate: GPM)

Size (in.)	0 to Min. Span Flow Rate GPM (0.33 ft/s)	0 to Max. Span Flow Rate GPM (33 ft/s)
0.1	0 to 0.0078	0 to 0.7780
0.2	0 to 0.0312	0 to 3.1122
0.4	0 to 0.1245	0 to 12.4488
0.5	0 to 0.2801	0 to 28.0098
1	0 to 0.7781	0 to 77.8050
1.25	0 to 1.2748	0 to 127.475
1.5	0 to 1.9919	0 to 199.181
2	0 to 3.1123	0 to 311.220
2.5	0 to 5.2597	0 to 525.962
3	0 to 7.9673	0 to 796.724
4	0 to 12.4489	0 to 1244.88
5	0 to 19.4513	0 to 1945.12
6	0 to 28.0099	0 to 2800.98
8	0 to 49.7953	0 to 4979.52
10	0 to 77.8051	0 to 7780.5
12	0 to 112.040	0 to 11203.9
14	0 to 152.498	0 to 15249.7
16	0 to 199.182	0 to 19918.1

(2) Combined with AXFA11 Remote Transmitter

SI Units (Size: mm, Flow rate: m<sup>3</sup>/h)

Size (mm)	0 to Min. Span Flow Rate m <sup>3</sup> /h (0.1 m/s)	0 to Max. Span Flow Rate m <sup>3</sup> /h (10 m/s)
2.5	0 to 0.0018	0 to 0.1767
5	0 to 0.0071	0 to 0.7068
10	0 to 0.0283	0 to 2.8274
15	0 to 0.0637	0 to 6.361
25	0 to 0.1768	0 to 17.671
32	0 to 0.2896	0 to 28.952
40	0 to 0.4524	0 to 45.23
50	0 to 0.7069	0 to 70.68
65	0 to 1.1946	0 to 119.45
80	0 to 1.8096	0 to 180.95
100	0 to 2.8275	0 to 282.74
125	0 to 4.418	0 to 441.7
150	0 to 6.362	0 to 636.1
200	0 to 11.310	0 to 1130.9
250	0 to 17.672	0 to 1767.1
300	0 to 25.447	0 to 2544.6
350	0 to 34.64	0 to 3463
400	0 to 45.24	0 to 4523
500	0 to 70.69	0 to 7068

English Units (Size: in., Flow rate: GPM)

Size (in.)	0 to Min. Span Flow Rate GPM (0.33 ft/s)	0 to Max. Span Flow Rate GPM (33 ft/s)
0.1	0 to 0.0078	0 to 0.7780
0.2	0 to 0.0312	0 to 3.112
0.4	0 to 0.1245	0 to 12.44
0.5	0 to 0.1946	0 to 19.45
1	0 to 0.7781	0 to 77.80
1.25	0 to 1.216	0 to 121.5
1.5	0 to 1.751	0 to 175.0
2	0 to 3.113	0 to 311.2
2.5	0 to 4.863	0 to 486.2
3	0 to 7.003	0 to 700.2
4	0 to 12.45	0 to 1244
5	0 to 19.46	0 to 1945
6	0 to 28.01	0 to 2800
8	0 to 49.80	0 to 4979
10	0 to 77.81	0 to 7780
12	0 to 112.1	0 to 11203
14	0 to 152.5	0 to 15249
16	0 to 199.2	0 to 19918
20	0 to 311.3	0 to 31122

5. Output Pulse Weight (Pulse Status Output 1)

Specify the volume flow per pulse, after specifying the span flow rate. This output pulse weight is set to the Pulse Status Output 1. Specify it in the same unit as the span flow rate.

(Example: When "m<sup>3</sup>" is selected as "Span Flow Rate", specify "10 m<sup>3</sup>/p" as pulse weight unit.)

The specifiable numerical digit and range is the same as that for "4. Span Flow Rate and Unit".

Unless specified, it is set as the following when shipped.

- Integral Flowmeter, or combined with AXG4A Remote Transmitter 0 [span unit/p]
- Combined with AXFA11 Remote Transmitter 0 pulse/s

6. Totalizer Display Pulse Weight (Totalizer 1)

Specify the volume flow per pulse, after specifying the span flow rate. This totalizer display pulse weight is set to the Totalizer 1. The set value can be output only in communication as the integrated count of the integral flowmeter and the remote transmitter. Specify it in the same unit as the span flow rate.

(Example: When "m<sup>3</sup>" is selected as "Span Flow Rate", specify "10 m<sup>3</sup>/p" as totalizer display pulse weight unit.)

The specifiable numerical digit and range is the same as that for "4. Span Flow Rate and Unit".

Unless specified, it is set as the following when shipped.

- Integral Flowmeter, or combined with AXG4A Remote Transmitter 1 [span unit/p]
- Combined with AXFA11 Remote Transmitter 0 pulse/s

7. Mass Unit (optional code MU)

The flow rate calculation is performed in mass unit. In addition to fluid density, specify span flow rate, output pulse weight, and totalizer display pulse weight in mass unit.

The specifiable numerical digit and range is the same as that for "4. Span Flow Rate and Unit".

(1) Density

Numerical Value:

Specify within six digits (up to three digits below the decimal point) in the range of 500 to 2000 kg/m<sup>3</sup> (4.2 to 16.7 lb/gal, 31.2 to 124.8 lb/cf). If BRAIN communication type is selected, specify so that the numerical value excluding the decimal point is within 32000.

Unit:

kg/m<sup>3</sup>, lb/gal, lb/cf

The density of water is about 1000 kg/m<sup>3</sup>. Then specify "1000 kg/m<sup>3</sup>" in this case.

However, as the density varies with temperature, specify the density at the time of flow measurement.

(2) Span Flow Rate

Numerical Value:

When setting the mass span flow rate, calculate the volume span flow rate from the "density" and it must be within the measurable flow rate range. The settable numerical range for the mass span flow rate is the same as that for the volume span flow rate.

Unit:

Mass Unit: t, kg, g, klb, lb

Time Unit: /d, /h, /min, /s

(3) Output Pulse Weight, Totalizer Display Pulse Weight

Set the value with the same unit as that for the mass span flow rate.

8. Specified Span Five-point Calibration (optional code SC)

A flow test at the five points around 0, 25, 50, 75, 100% of the customer specified span is performed. In the test certificate (QIC), the result for the customer specified span is recorded instead of that for the standard flow rate of 2 m/s (6.56 ft/s). Corresponding flow velocity of the selectable span lies between 0.5 to 10 m/s (1.64 to 33 ft/s) or 0.8 to 10 m/s (2.62 to 33 ft/s). The latter is applied when the size is 32, 65, or 125 mm (1.25, 2.5, or 5 in.). It is also limited by the capacity of our flow test facility. Specify it within the following range. The specifiable numerical digit and range is the same as that for "4. Span Flow Rate and Unit".

Selectable Range of Span Flow Rate

SI Units (Size: mm, Flow rate: m³/h)

Size (mm)	Min. Span Flow Rate	Max. Span Flow Rate
	m³/h (m/s)	m³/h (m/s)
2.5	0.009 (0.5)	0.05 (2.83)
5	0.036 (0.5)	0.20 (2.83)
10	0.15 (0.5)	0.96 (3.40)
15	0.32 (0.5)	2.80 (4.40)
25	0.89 (0.5)	11.0 (6.22)
32	2.32 (0.8)	28.9 (9.98)
40	2.27 (0.5)	28.0 (6.19)
50	3.54 (0.5)	56.0 (7.92)
65	9.56 (0.8)	80.0 (6.70)
80	9.05 (0.5)	126 (6.96)
100	14.2 (0.5)	190 (6.72)
125	35.4 (0.8)	300 (6.79)
150	31.9 (0.5)	380 (5.97)
200	56.6 (0.5)	670 (5.92)
250	88.4 (0.5)	1000 (5.66)
300	128 (0.5)	1200 (4.72)
350	174 (0.5)	1200 (3.46)
400	227 (0.5)	1350 (2.98)
500	354 (0.5)	7068 (10.0)

English Units (Size: in., Flow rate: GPM)

Size (in.)	Min. Span Flow Rate	Max. Span Flow Rate
	GPM (ft/s)	GPM (ft/s)
0.1	0.039 (1.64)	0.2201 (9.28)
0.2	0.1557 (1.64)	0.8805 (9.28)
0.4	0.6225 (1.64)	4.2267 (11.1)
0.5	1.4005 (1.64)	12.328 (14.4)
1	3.8903 (1.64)	48.4315 (20.4)
1.25	10.1981 (2.62)	127.242 (32.7)
1.5	9.9591 (1.64)	123.280 (20.3)
2	15.5611 (1.64)	246.560 (25.9)
2.5	42.0770 (2.62)	352.229 (21.9)
3	39.8363 (1.64)	554.761 (22.8)
4	62.2441 (1.64)	836.544 (22.0)
5	156.052 (2.62)	1320.86 (22.2)
6	140.050 (1.64)	1673.08 (19.5)
8	248.977 (1.64)	2949.92 (19.4)
10	389.026 (1.64)	4402.86 (18.5)
12	560.197 (1.64)	5283.44 (15.4)
14	762.490 (1.64)	5283.44 (11.3)
16	995.906 (1.64)	5943.87 (9.78)
20	1556.11 (1.64)	31119.4 (32.8)

9. Direction of Cable Entry (optional code RH)

Rotate the transmitter of integral flowmeter or the terminal box of remote sensor and change the direction of the cable entry. See the table below and specify either +90, +180, or -90 degree. When the direction of cable entry is not changed, optional code RH is not necessary.

	Direction of Cable Entry			
	Standard (0 degree)	+90 degree rotation	+180 degree rotation	-90 degree rotation
Integral Flowmeter				
Remote Sensor				

10. Direction of Display

When the specification "With Display" is selected for the integral flowmeter or the remote transmitter, specify direction of the display. For the integral flowmeter, specify according to the horizontal or vertical direction of the installation piping. For the remote transmitter, specify according to the positional relation of mounting bracket or mounting pipe.

	Direction of Display		Without Display
	Horizontal	Vertical	
Integral Flowmeter			
Remote Transmitter			

11. Fluid Name

■ RELATED INSTRUMENTS

Product	Document Number
AM012 Calibrator for Magnetic Flowmeter	GS 1E6K2-E
BT200 BRAIN TERMINAL	GS 01C00A11-00EN
AXFA11G Magnetic Flowmeter Remote Converter	GS 01E20C01-01E
ADMAG CA Capacitance Magnetic Flowmeter	GS 01E08B01-00E
FieldMate Versatile Device Management Wizard	GS 01R01A01-01E
ADMAG TI Series AXW Magnetic Flowmeter [Size: 25 to 400 mm (1 to 16 in.)]	GS 01E24A01-01EN
ADMAG TI Series AXW Magnetic Flowmeter [Size: 500 to 1800 mm (20 to 72 in.)]	GS 01E25D11-01EN
FSA130 ADMAG TI Verification Tool	GS 01E21A04-01EN

■ REFERENCE STANDARD

Design and Test on Magnetic Flowmeters:

- JIS B 7554(1997), ISO 20456(2017),
- NAMUR NE70(2006), ASME MFC-16-2014

■ TRADEMARKS

HART is a registered trademark of FieldComm Group.

Viton is a registered trademark of DuPont.

Tri-Clamp is a registered trademark of Alfa Laval.

ADMAG, AXG, AXW, BRAIN TERMINAL, and FieldMate are registered trademarks of Yokogawa Electric Corporation.

All other company and product names mentioned in this document are trade names, trademarks or registered trademarks of their respective companies.

In this document, trademarks or registered trademarks are not marked with ™ or ®.

Note: The terms “transmitter” and “sensor” in this document are used in the same manner as “converter” and “flowtube” respectively which are used for our previous magnetic flowmeter models.